

Thursday 9 June 2022 – Afternoon

GCSE (9–1) Physics B (Twenty First Century Science)

J259/03 Breadth in physics (Higher Tier)

Time allowed: 1 hour 45 minutes



You must have:

- a ruler (cm/mm)
- the Data Sheet for GCSE (9–1) Physics B (inside this document)

You can use:

- a scientific or graphical calculator
- an HB pencil



Please write clearly in black ink. **Do not write in the barcodes.**

Centre number

--	--	--	--	--

Candidate number

--	--	--	--

First name(s)

Last name

INSTRUCTIONS

- Use black ink. You can use an HB pencil, but only for graphs and diagrams.
- Write your answer to each question in the space provided. If you need extra space use the lined pages at the end of this booklet. The question numbers must be clearly shown.
- Answer **all** the questions.
- Where appropriate, your answers should be supported with working. Marks might be given for using a correct method even if your answer is wrong.

INFORMATION

- The total mark for this paper is **90**.
- The marks for each question are shown in brackets [].
- This document has **32** pages.

ADVICE

- Read each question carefully before you start your answer.

2
BLANK PAGE

PLEASE DO NOT WRITE ON THIS PAGE

Answer **all** the questions.

- 1 Nina investigates how the resistance of a thermistor depends on its temperature.

She controls the temperature of the thermistor by placing it in a beaker of water at different temperatures.

Fig. 1.1 shows part of her circuit diagram.

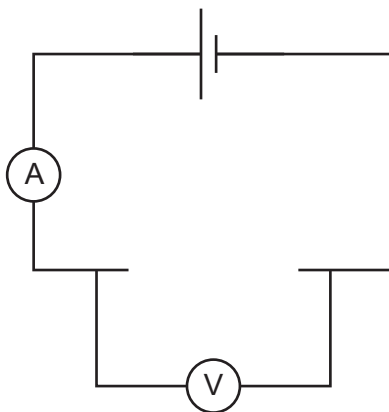

Fig. 1.1

- (a) Complete **Fig. 1.1** to include a thermistor correctly connected to the circuit. [1]

- (b) **Table 1.1** shows her data.

Temperature ($^{\circ}\text{C}$)	Resistance (Ω)
0	1300
80	1800

Table 1.1

Nina

My hypothesis is that as temperature increases, resistance increases.

To test this, I need a measurement at a temperature of about 50°C .



- (i) Suggest how she could make water with a temperature of about 50°C .

.....
 [1]

(ii) **Table 1.2** shows her data including the measurement at 50 °C.

Temperature (°C)	Resistance (Ω)
0	1300
50	350
80	1800

Table 1.2

How will the new data affect Nina's confidence in her hypothesis?

Explain your answer.

Tick (✓) **one** box.

Less confident

More confident

No effect

Explanation:

.....

..... [2]

(c) Nina made 7 more measurements at different temperatures.

All her data is plotted in **Fig. 1.2**.

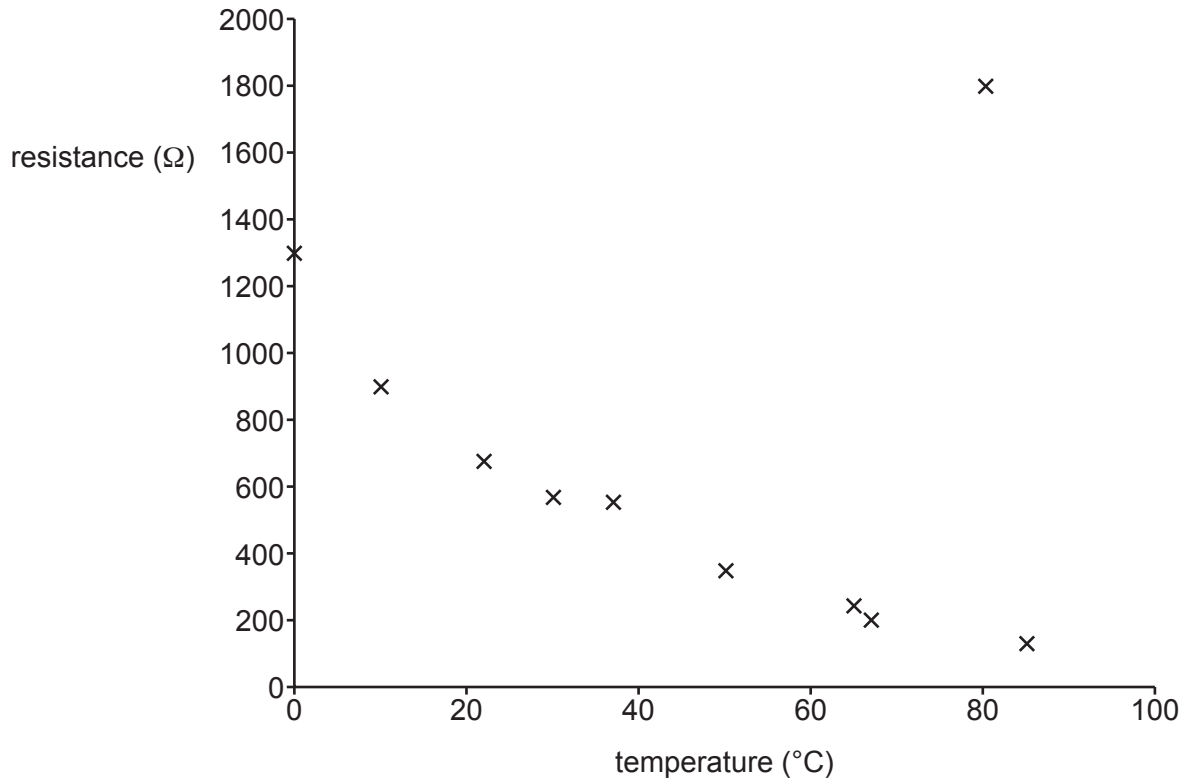

Fig. 1.2

Describe the trend shown in **Fig. 1.2**.

.....

.....

.....

..... [2]

2 Jamal, Sara and Jack are playing rounders.

Rounders is a game played with a bat and ball. **Fig. 2.1** shows the layout of the pitch. The bowler stands at X and throws the ball towards the batter at Y.

The batter hits the ball and then tries to run around the pitch once, from Y to Z.

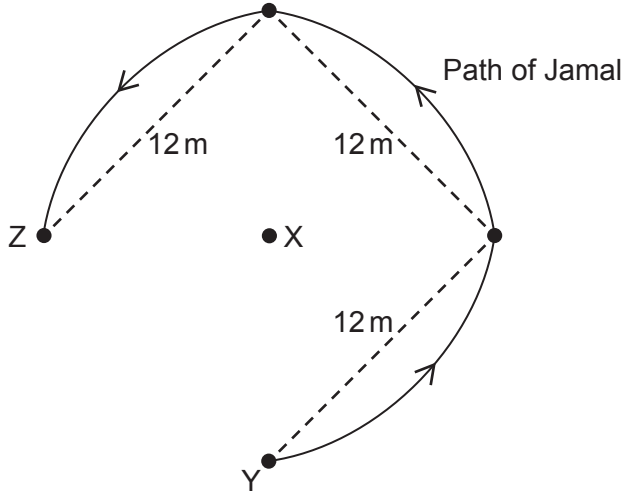



Fig. 2.1

(a) Jamal hits the ball and runs along the path from Y to Z shown in **Fig. 2.1**.

Sara

The distance travelled by Jamal is different to his displacement.



Explain why Sara is correct. Use information from **Fig. 2.1** in your answer.

.....

.....

.....

..... [2]

(b) Sara and Jack try to estimate how quickly Jamal speeded up.

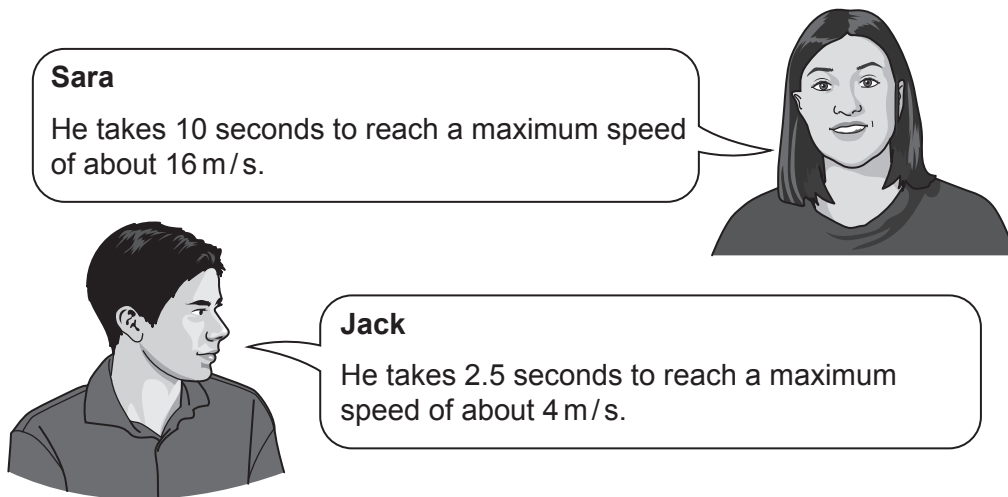

Sara
He takes 10 seconds to reach a maximum speed of about 16 m/s.

Jack
He takes 2.5 seconds to reach a maximum speed of about 4 m/s.

(i) Which is the better estimate? Explain your answer.

Tick (✓) **one** box.

Sara

Jack

.....
 [1]

(ii) Use **either** estimate to calculate Jamal's acceleration.

Use the Data Sheet.

Acceleration = m/s² [3]

3 Cancer can be treated using radiation. This is called radiotherapy.

The diagram shows one way to use gamma rays to treat cancer.

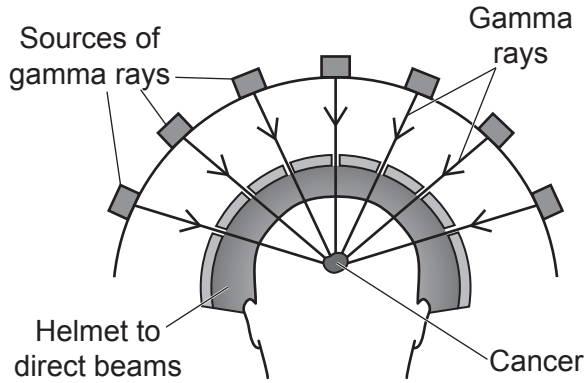

(a) Describe why gamma rays can be used to treat cancer using the method shown in the diagram.

.....

.....

.....

.....

.....

.....

.....

.....

.....

.....

.....

..... [3]

(b) Ben's cancer is treated using gamma rays.

Ben
After the radiotherapy I will be contaminated with radiation.



Explain why Ben is wrong.

.....

.....

..... [2]

(c) X-rays can also be used for radiotherapy.

X-rays are produced electrically using a machine.

Suggest an advantage of treating cancer using X-rays instead of gamma rays.

.....

.....

..... [1]

4 Different types of wave can be used for communications.

Fifty years ago, microwaves were used for long distance communications. Microwaves travel through the air between microwave aerials.

Now, light waves travelling along optical fibres are normally used instead.

(a) Compare and contrast microwaves and light waves.

.....
.....
..... [2]

(b) The table shows information about these waves.

How it works	Speed of wave (m/s)	Time to travel 90 km (μs)
Microwaves in air	3.0×10^8	300
Light waves in an optical fibre		450

(i) Calculate the speed of light waves in an optical fibre.

Use the Data Sheet.

Speed = m/s [4]

(ii) An engineer suggests using an optical fibre made using a new material.

In this new material, light waves take $432\ \mu\text{s}$ to travel 90 km.

Calculate the percentage decrease in the travel time for this new material.

Percentage decrease = % [2]

(iii) The new material would be 10% more expensive than the old material.

Suggest why it is not worth using the new material. Use your answer to part (b)(ii).

.....
.....
..... [1]

5 Alex investigates the efficiency of a motor.

He uses the motor to lift a weight as shown in the diagram.

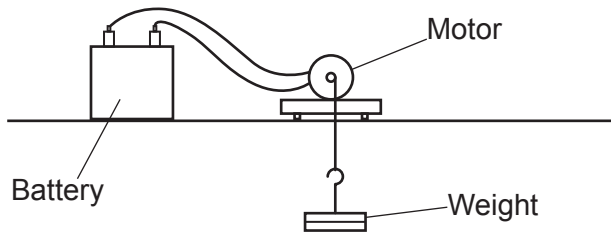

He takes measurements and calculates the energy transfers.

(a) The electrical energy input to the motor is 5.6 J.

The work done lifting the weight is 3.5 J.

The motor is switched on for 20 seconds.

(i) Calculate the electrical power input to the motor.

Use the Data Sheet.

Power input = W [3]

(ii) Calculate the efficiency of the motor when lifting the weight.

Use the Data Sheet.

Efficiency = % [3]

(b) Alex researches how to improve the efficiency of the energy transfer.

Alex
Adding thermal insulation to the motor will increase its efficiency.



(i) Explain why Alex is wrong.

.....

.....

.....

..... [2]

(ii) Suggest a better method to increase the efficiency of the energy transfer.

.....

..... [1]

6 Mia's teacher uses a Van de Graaff generator to demonstrate static electricity shown in **Fig. 6.1**.

Electrons are transferred to the metal dome, giving it a negative charge.

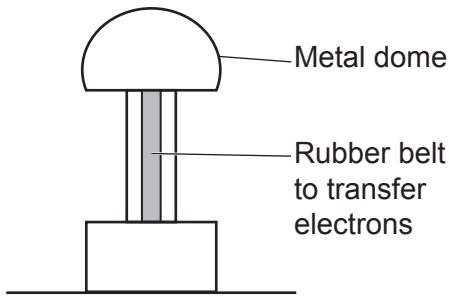

Fig. 6.1

(a) In **Fig. 6.2** a doll's head is attached to the top of the dome. When the dome is charged, the doll's hair also becomes negatively charged. The hair stands on end.

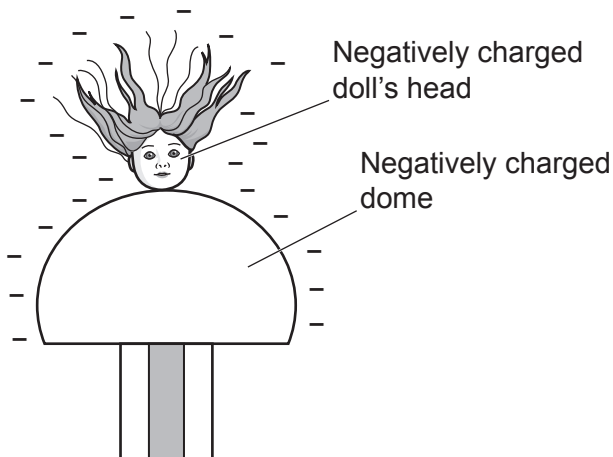



Fig. 6.2

Mia discusses the experiment with her teacher.

Mia

The hair stands on end because of an electric field.



Explain why.

.....

.....

.....

.....

[2]

- (b) Mia's teacher switches off the Van de Graaff generator. He then uses a wooden metre rule to discharge the dome shown in Fig. 6.3.

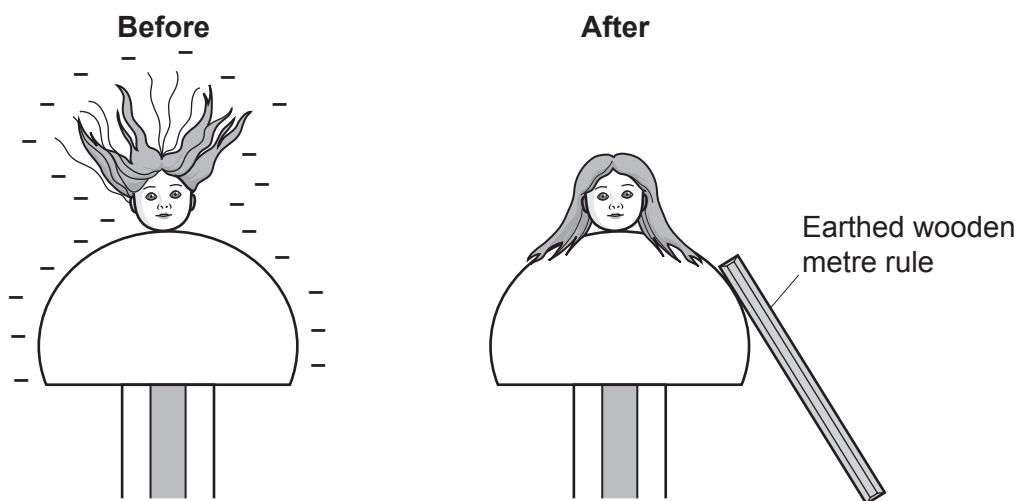

Fig. 6.3

The initial voltage of the charged dome is 120 000 V. The initial charge on the dome is $1.5 \mu\text{C}$. The resistance of the wooden rule is $5.0 \times 10^{11} \Omega$.

- (i) Calculate the initial current that flowed through the wooden rule.

Use the Data Sheet.

Current = A [3]

- (ii) Mia's teacher talks about how he discharged the dome.

Mia's teacher

It is possible to discharge the dome using a wooden rule even though it has a high resistance. The wooden rule discharges slowly.



Use the information given in part (b) to explain why it was possible to discharge the dome using the wooden metre rule. You may include a calculation in your answer.

.....

.....

.....

..... [2]

7 Kareem investigates floating and sinking.

He places a block of wood in salty water as shown in **Fig. 7.1**. The block of wood floats.

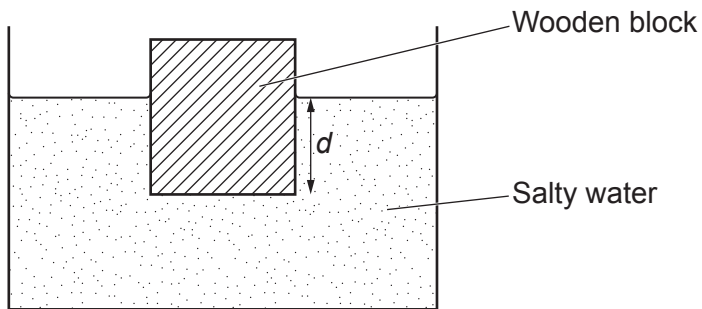

Fig. 7.1

(a) The weight of the block of wood is 0.48 N.

The water pressure acting on the base of the block of wood is 300 Pa.

The density of the salty water is 1200 kg/m^3 .

Gravitational field strength = 10 N/kg .

(i) Calculate the surface area of the bottom of the block of wood.

Use the Data Sheet.

Surface area = m^2 [3]

(ii) Calculate the depth d shown on **Fig. 7.1**.

Use the Data Sheet.

Depth d = m [3]

(b) Kareem compares how the wooden block and a copper block behave in different liquids.

Fig. 7.2 shows his results.

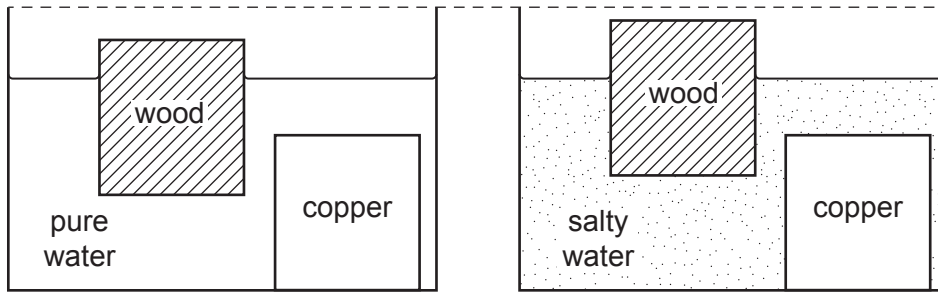

Fig. 7.2

The table shows the densities of the materials and liquids he uses.

Material	Density (kg/m ³)
Wood	750
Copper	9000
Pure water	1000
Salty water	1200

Explain why the wooden block floats higher in salty water.

.....

.....

.....

.....

.....

..... [3]

8 Eve investigates the reflection of white light from a mirror.

Fig. 8.1 shows her equipment.

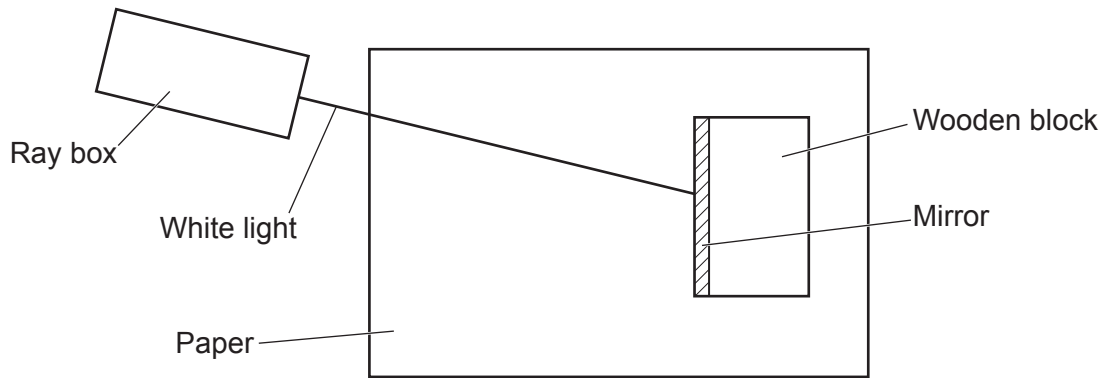

Fig. 8.1

(a) Describe a method to record the path of the ray of light shown in Fig. 8.1.

.....
.....
..... [2]

(b) Fig. 8.2 shows a ray of light striking the mirror.

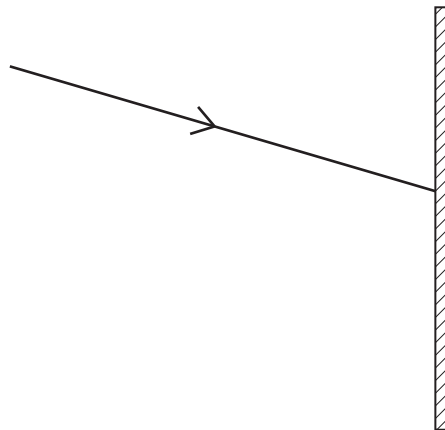

Fig. 8.2

Complete Fig. 8.2 to show the ray of light reflected from the mirror.

[2]

- (c) Eve wants to investigate whether infrared radiation reflects from a mirror at the same angle as visible light.

Suggest how she can produce and detect infrared radiation to complete this investigation.

.....

.....

..... [2]

9 Gears are used in many household appliances.

(a) Fig. 9.1 shows two gears A and B.

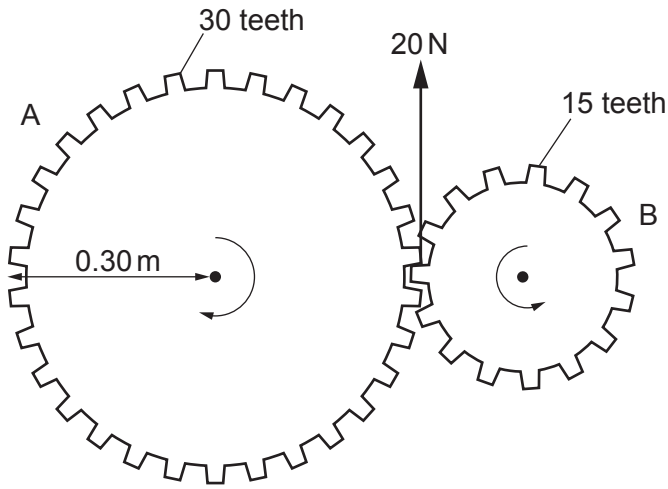

Fig. 9.1

Use the information in Fig. 9.1 to answer these questions.

Use the Data Sheet.

(i) Gear B exerts a 20 N force on Gear A.

Calculate the moment of the 20 N force on Gear A.

Moment = Nm [3]

(ii) Gear A also exerts a force on Gear B.

Compare the forces and moments acting on Gear A and Gear B.

.....

 [2]

(b) Gear C is added, as shown in **Fig. 9.2**.

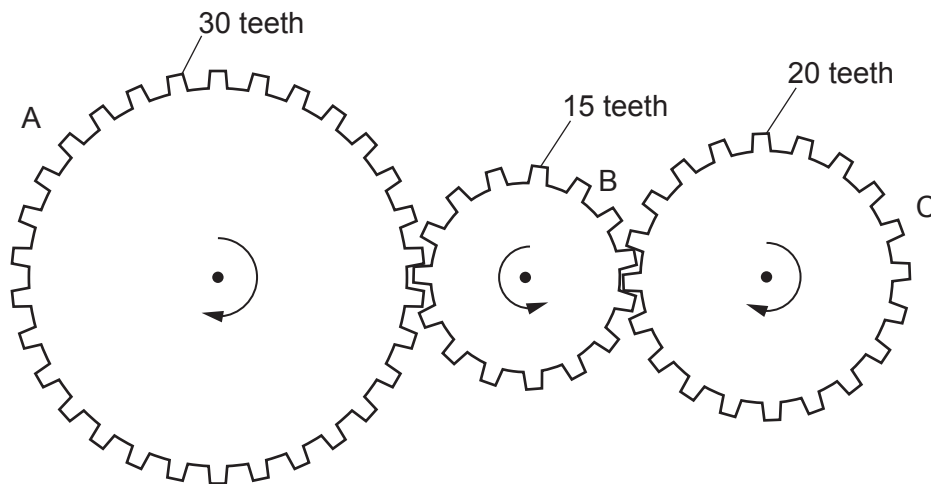

Fig. 9.2

Gear A rotates 24 times in one minute.

How many times does **gear C** rotate in one minute?

Rotations in one minute = [2]

10 Ben uses a battery-powered shaver.

The shaver uses an electric motor to move the blades.

(a) Describe the changes in stored energy when the shaver is switched on.

.....

.....

..... [2]

(b) Fig. 10.1 shows a simplified diagram of the electric motor in the shaver.

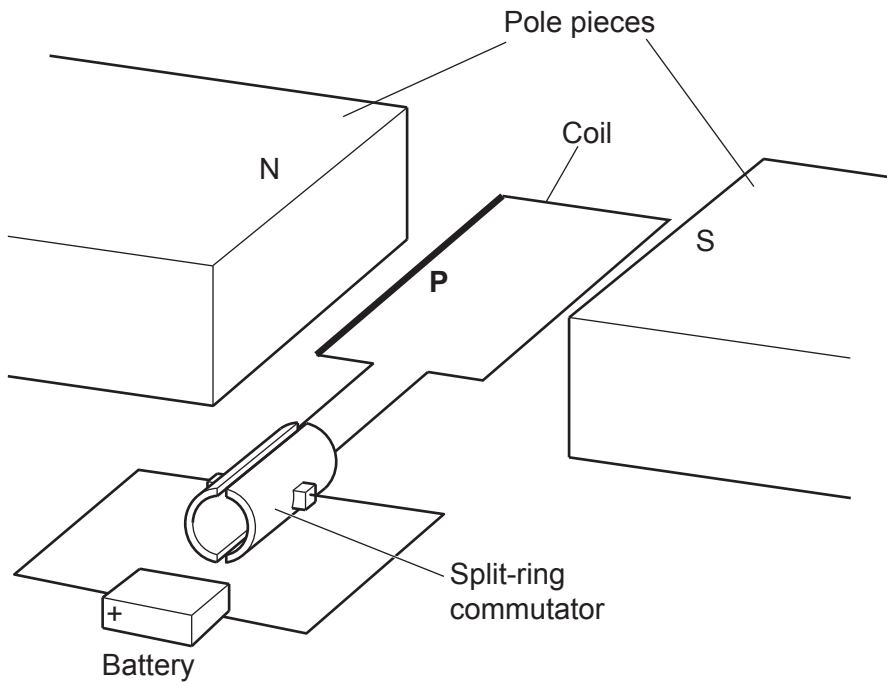

Fig. 10.1

- (i) The wire **P** experiences a downwards magnetic force of 2.4×10^{-4} N when it carries a current of 0.80A. The length of wire **P** is 0.012 m.

Use the Data Sheet.

Calculate the magnetic flux density.

Magnetic flux density = T [3]

- (ii) Explain why the coil of wire in the motor rotates.

.....

.....

.....

..... [2]

- 11 The sensitivity of the human ear to sound waves depends on frequency. Perceived loudness is how loud a sound appears to be when you hear it.

Fig. 11.1 shows how perceived loudness depends on frequency for a typical human ear.

The range of frequencies shown is the most sensitive range for the human ear.

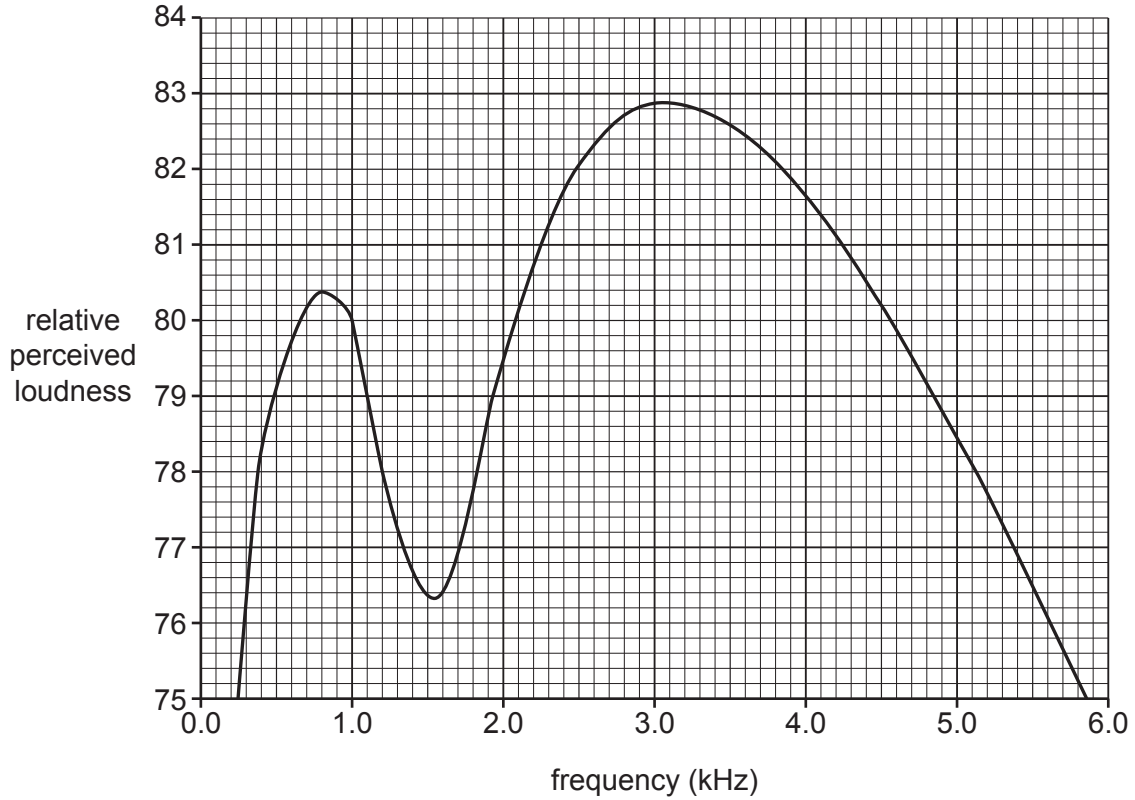

Fig. 11.1

- (a) Use Fig. 11.1 to determine the frequency at which the human ear is most sensitive.

Frequency = kHz [1]

- (b) Describe how sounds are transmitted through the middle ear and suggest how this could affect the perceived loudness of different frequency sounds.

.....

.....

.....

.....

.....

.....

..... [2]

- (c) Eve’s hearing is tested and is typical for the human ear. Describe how the loudness of the sound she hears changes when she listens to a sound, with constant amplitude, that gradually increases in frequency from 500 Hz to 5000 Hz.

Use information from **Fig. 11.1**.

.....

.....

.....

..... [2]

12 The Sun formed when gravity caused a cloud of dust and gas to collapse.

(a) Use the particle model to explain why the temperature of the cloud of dust and gas increased as it collapsed.

.....

.....

.....

.....

.....

.....

.....

..... [3]

(b) There are many stars similar to the Sun. The graph shows the relative mass and relative energy output of several stars similar to the Sun.

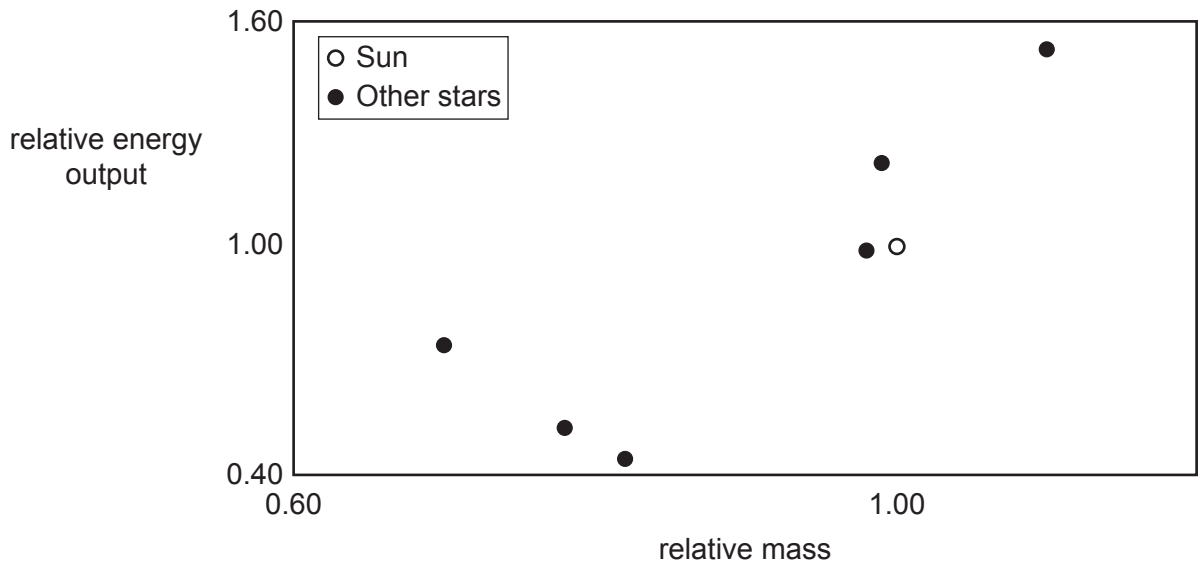

(i) Stars with a larger mass exert a larger gravitational force.

Use this information to explain the trend shown in the graph.

.....

.....

.....

.....

..... [2]

(ii) Beth evaluates the quality of the data.

Beth

The data on the graph is very scattered. The stars do not follow the trend exactly.



Suggest why measurements of stars produce very scattered data.

.....
..... [1]

13 Layla is designing a torch. She builds a circuit using a cell and 6 identical light-emitting diodes (LEDs).

Fig. 13.1 shows her circuit.

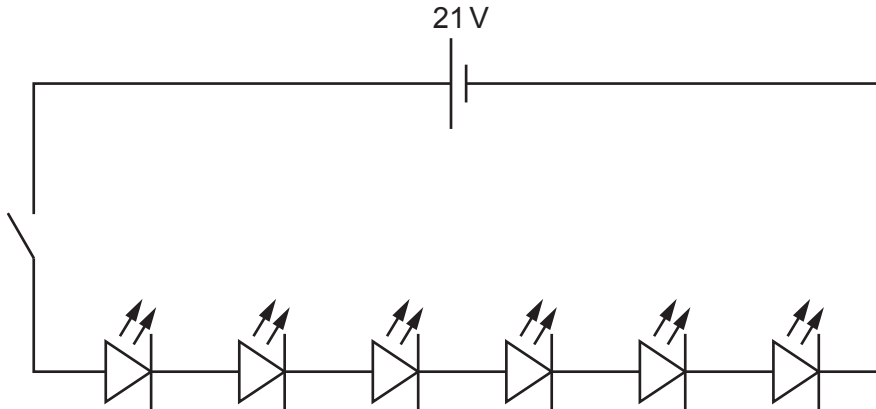

Fig. 13.1

(a) The switch is closed. Show that the potential difference across each LED is 3.5V.

[1]

(b) Fig. 13.2 shows the voltage-current characteristic for one LED.

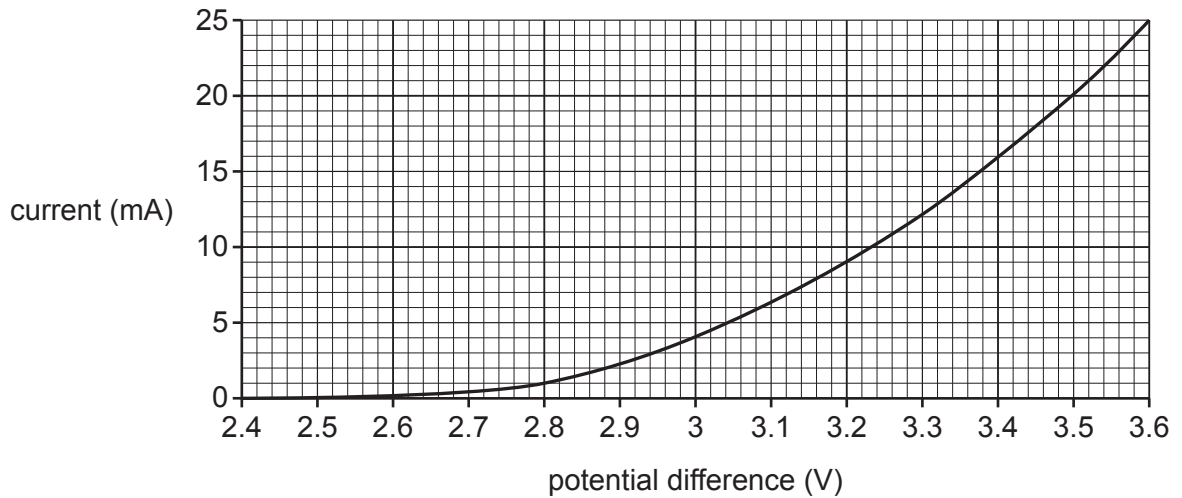

Fig. 13.2

Use the Data Sheet.

Calculate the power delivered to each LED in this circuit.

Power =W [3]

(c) Fig. 13.3 shows how the intensity of light from each LED is related to the current.

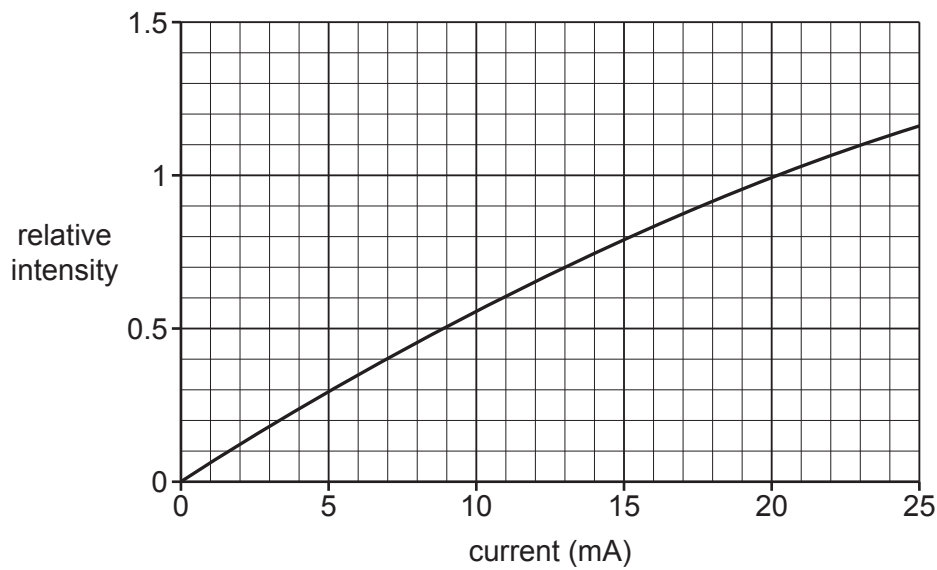

Fig. 13.3

Layla considers adding one extra LED to her circuit.

Use the data in Fig. 13.2 and Fig. 13.3 to explain whether the torch will be brighter with 6 or 7 LEDs.

Include a calculation in your answer.

.....

.....

.....

.....

.....

.....

.....

..... [3]

END OF QUESTION PAPER

ADDITIONAL ANSWER SPACE

If additional space is required, you should use the following lined page(s). The question number(s) must be clearly shown in the margin(s).

A large area of lined paper for writing, consisting of 25 horizontal dotted lines. A solid vertical line runs down the left side of the page, creating a margin. The rest of the page is open for writing.

A large area of the page is reserved for writing, featuring a vertical solid line on the left side and horizontal dotted lines extending across the page.



Copyright Information

OCR is committed to seeking permission to reproduce all third-party content that it uses in its assessment materials. OCR has attempted to identify and contact all copyright holders whose work is used in this paper. To avoid the issue of disclosure of answer-related information to candidates, all copyright acknowledgements are reproduced in the OCR Copyright Acknowledgements Booklet. This is produced for each series of examinations and is freely available to download from our public website (www.ocr.org.uk) after the live examination series. If OCR has unwittingly failed to correctly acknowledge or clear any third-party content in this assessment material, OCR will be happy to correct its mistake at the earliest possible opportunity.

For queries or further information please contact The OCR Copyright Team, The Triangle Building, Shaftesbury Road, Cambridge CB2 8EA.

OCR is part of Cambridge University Press & Assessment, which is itself a department of the University of Cambridge.