GCSE
COMPUTER SCIENCE
8525/2

Paper 2 Computing Concepts

Mark scheme

June 2022

Version:1.0 Final



Mark schemes are prepared by the Lead Assessment Writer and considered, together with the relevant questions, by a panel of subject teachers. This mark scheme includes any amendments made at the standardisation events which all associates participate in and is the scheme which was used by them in this examination. The standardisation process ensures that the mark scheme covers the students' responses to questions and that every associate understands and applies it in the same correct way. As preparation for standardisation each associate analyses a number of students' scripts. Alternative answers not already covered by the mark scheme are discussed and legislated for. If, after the standardisation process, associates encounter unusual answers which have not been raised they are required to refer these to the Lead Examiner.

It must be stressed that a mark scheme is a working document, in many cases further developed and expanded on the basis of students' reactions to a particular paper. Assumptions about future mark schemes on the basis of one year's document should be avoided; whilst the guiding principles of assessment remain constant, details will change, depending on the content of a particular examination paper.

Further copies of this mark scheme are available from aqa.org.uk

The following annotation is used in the mark scheme:

- ;** - means a single mark
- //** - means alternative response
- /** - means an alternative word or sub-phrase
- A** - means acceptable creditworthy answer. Also used to denote a valid answer that goes beyond the expectations of the GCSE syllabus.
- R** - means reject answer as not creditworthy
- NE** - means not enough
- I** - means ignore
- DPT** - in some questions a specific error made by a candidate, if repeated, could result in the candidate failing to gain more than one mark. The DPT label indicates that this mistake should only result in a candidate losing one mark on the first occasion that the error is made. Provided that the answer remains understandable, subsequent marks should be awarded as if the error was not being repeated.

Copyright information

AQA retains the copyright on all its publications. However, registered schools/colleges for AQA are permitted to copy material from this booklet for their own internal use, with the following important exception: AQA cannot give permission to schools/colleges to photocopy any material that is acknowledged to a third party even for internal use within the centre.

Copyright © 2022 AQA and its licensors. All rights reserved.

Level of response marking instructions

Level of response mark schemes are broken down into levels, each of which has a descriptor. The descriptor for the level shows the average performance for the level. There are marks in each level.

Before you apply the mark scheme to a student's answer read through the answer and annotate it (as instructed) to show the qualities that are being looked for. You can then apply the mark scheme.

Step 1 Determine a level

Start at the lowest level of the mark scheme and use it as a ladder to see whether the answer meets the descriptor for that level. The descriptor for the level indicates the different qualities that might be seen in the student's answer for that level. If it meets the lowest level then go to the next one and decide if it meets this level, and so on, until you have a match between the level descriptor and the answer. With practice and familiarity you will find that for better answers you will be able to quickly skip through the lower levels of the mark scheme.

When assigning a level you should look at the overall quality of the answer and not look to pick holes in small and specific parts of the answer where the student has not performed quite as well as the rest. If the answer covers different aspects of different levels of the mark scheme you should use a best fit approach for defining the level and then use the variability of the response to help decide the mark within the level, ie if the response is predominantly level 3 with a small amount of level 4 material it would be placed in level 3 but be awarded a mark near the top of the level because of the level 4 content.

Step 2 Determine a mark

Once you have assigned a level you need to decide on the mark. The descriptors on how to allocate marks can help with this. The exemplar materials used during standardisation will help. There will be an answer in the standardising materials which will correspond with each level of the mark scheme. This answer will have been awarded a mark by the Lead Examiner. You can compare the student's answer with the example to determine if it is the same standard, better or worse than the example. You can then use this to allocate a mark for the answer based on the Lead Examiner's mark on the example.

You may well need to read back through the answer as you apply the mark scheme to clarify points and assure yourself that the level and the mark are appropriate.

Indicative content in the mark scheme is provided as a guide for examiners. It is not intended to be exhaustive and you must credit other valid points. Students do not have to cover all of the points mentioned in the Indicative content to reach the highest level of the mark scheme.

An answer which contains nothing of relevance to the question must be awarded no marks.

Qu	Part	Marking guidance	Total marks
01	1	Mark is for AO2 (apply) 212;	1

Qu	Part	Marking guidance	Total marks
01	2	2 marks for AO2 (apply) B; (This must be the left digit to gain the mark) 9; (This must be the right digit to gain the mark)	2

Qu	Part	Marking guidance	Total marks
01	3	Mark is for AO2 (apply) 63; // $2^6 - 1$;	1

Qu	Part	Marking guidance	Total marks
02	1	2 marks for AO2 (apply) 1110; 1001;	2

Qu	Part	Marking guidance	Total marks
02	2	Mark is for AO2 (apply) 00010101;	1

Qu	Part	Marking guidance	Total marks
02	3	Mark is for AO1 (understanding) The (binary) number is multiplied by 16 // 2^4 ; Note for examiners: equivalent arithmetic methods should be credited.	1

Qu	Part	Marking guidance	Total marks
02	4	Mark is for AO1 (understanding) To divide by 4 // quarter the number // multiplies by 8 then divides by 32; Note for examiners: equivalent arithmetic methods should be credited.	1

Qu	Part	Marking guidance	Total marks															
03	1	<p>Mark is for AO1 (understanding)</p> <table border="1" style="margin-left: auto; margin-right: auto;"> <thead> <tr> <th>A</th> <th>B</th> <th>A XOR B</th> </tr> </thead> <tbody> <tr> <td>0</td> <td>0</td> <td>0</td> </tr> <tr> <td>0</td> <td>1</td> <td>1</td> </tr> <tr> <td>1</td> <td>0</td> <td>1</td> </tr> <tr> <td>1</td> <td>1</td> <td>0</td> </tr> </tbody> </table> <p>1 mark for correct column A XOR B;</p> <p>A. F / FALSE / False / Off instead of 0 A. T / TRUE / True / On instead of 1 R. if correct outputs but mix of styles given eg F, T, T, 0.</p>	A	B	A XOR B	0	0	0	0	1	1	1	0	1	1	1	0	1
A	B	A XOR B																
0	0	0																
0	1	1																
1	0	1																
1	1	0																

Qu	Part	Marking guidance	Total marks
03	2	<p>3 marks for AO2 (apply)</p> <p>Maximum of two marks (if not fully correct) from:</p> <ul style="list-style-type: none"> • D is always the only input to a NOT gate with correct symbol used; • AND gate with two correct inputs with correct symbol used; • R is always the only output from a second AND gate with correct symbol used; 	3

Qu	Part	Marking guidance	Total marks
		<p>Example 1</p>	

Example 2

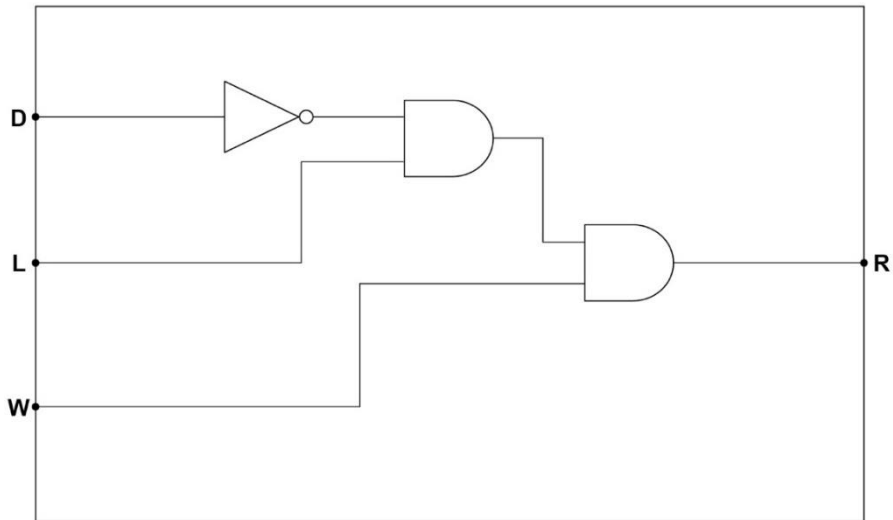

Example 3

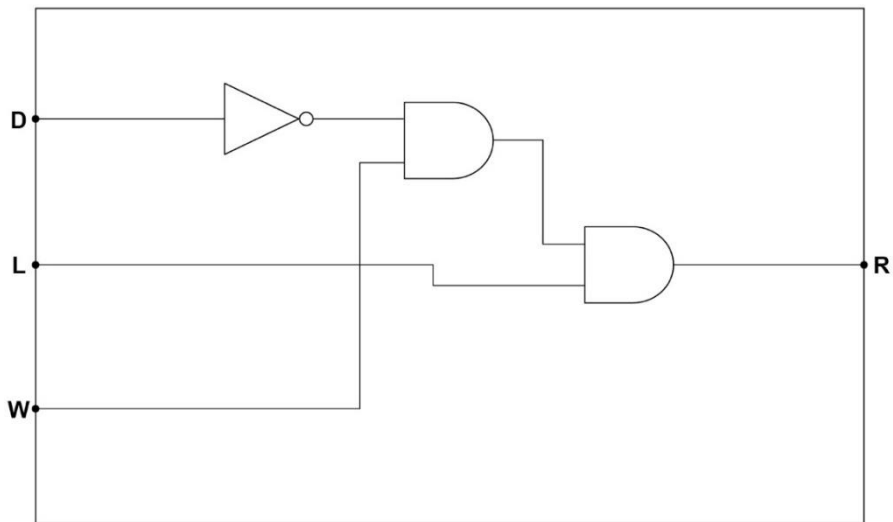

R. incorrect symbols

Qu	Part	Marking guidance	Total marks
03	3	<p>Mark is for AO2 (apply)</p> <p>C $(W \cdot D) + (D \cdot L) + (W \cdot L)$;</p> <p>R. if more than one lozenge shaded</p>	1

Qu	Part	Marking guidance	Total marks
03	4	<p>3 marks for AO2 (apply)</p> <p>$\bar{D}. \bar{L}. W // W. (\bar{D} + \bar{L}) // (\bar{D}. W). (\bar{L}. W) ; ; ;$</p> <p>2 marks if fully correct but using different notation, eg NOT D AND NOT L AND W;; W AND NOT (D OR L);; (NOT D AND W) AND (NOT L AND W);;</p> <p>Maximum of two marks (if not fully correct) from:</p> <ul style="list-style-type: none"> • 1 mark for using Boolean operator symbols throughout the expression; (for this year only) • 1 mark for $W + (\bar{D}. \bar{L})$; • 1 mark for $\bar{D} + \bar{L} + W$; • 1 mark for $(\bar{D} + W) + (\bar{L} + W)$; 	3

Qu	Part	Marking guidance	Total marks
04	1	<p>2 marks for AO1 (recall)</p> <p>System software (Maximum of one mark from:)</p> <ul style="list-style-type: none"> • Manages / controls computer hardware; • Manages application software; • Manages / runs / controls a computer (system); • Manages the operation of the computer (system); <p>Application software</p> <ul style="list-style-type: none"> • Is for (end-)user tasks; 	2

Qu	Part	Marking guidance	Total marks
04	2	<p>4 marks for AO1 (recall)</p> <p>Maximum of four marks from:</p> <ul style="list-style-type: none"> • Processor / task / process management; • Memory management; • I/O device management; A. Peripheral Management (for this year only) • Applications management; • Security management; • File / storage management; • Network management; <p>A. Provides a user interface</p>	4

Qu	Part	Marking guidance	Total marks															
05		<p>6 marks for AO2 (apply)</p> <table border="1"> <thead> <tr> <th>Level</th> <th>Description</th> <th>Mark range</th> </tr> </thead> <tbody> <tr> <td>3</td> <td>There is a structured discussion of both the legal and ethical impacts of the increased use of autonomous vehicles.</td> <td>5–6</td> </tr> <tr> <td>2</td> <td>There is an explanation of the legal and/or ethical impacts of the increased use of autonomous vehicles. Answers may focus on only one aspect (legal or ethical) but clear and relevant points are made.</td> <td>3–4</td> </tr> <tr> <td>1</td> <td>There is some reference to the legal and/or ethical impacts of the increased use of autonomous vehicles but the points made may not always be clear or well-explained.</td> <td>1–2</td> </tr> <tr> <td colspan="2">No creditworthy material</td> <td>0</td> </tr> </tbody> </table> <p>Guidance:</p> <p>Ethical impacts</p> <ul style="list-style-type: none"> • Trust. The driver is trusting the algorithms in the car to make the correct decisions whilst driving eg slowing down when pedestrians are in the road. • Decision making. The car must make human-like decisions when confronted with unusual circumstances eg the 'trolley problem'. • Safer driving. Autonomous vehicles could be safer drivers than human drivers eg by keeping a safe distance from the car in front at all times. • Data collection. Autonomous vehicles may collect private data about their passengers such as locations visited. Passengers may want to keep their journeys private. • Job opportunities. Fewer roles needed for some professions such as taxi drivers but other opportunities could be created. • Accessibility. Disabled passengers will not have to operate traditional car controls. <p>Legal impacts</p> <ul style="list-style-type: none"> • Liability. There is a grey area about who is at fault (the manufacturer or the driver) in case of an accident. • Insurance. The need for driving insurance will change as drivers are no longer responsible for the control of the car. • Data protection. Car manufacturers must keep driving data secure in accordance with data protection laws. • Security. Autonomous vehicles could be vulnerable to being hacked and hijacked for criminal purposes. • Law updates. Driving laws will need to be amended to account for new types of vehicles on the roads. 	Level	Description	Mark range	3	There is a structured discussion of both the legal and ethical impacts of the increased use of autonomous vehicles.	5–6	2	There is an explanation of the legal and/or ethical impacts of the increased use of autonomous vehicles. Answers may focus on only one aspect (legal or ethical) but clear and relevant points are made.	3–4	1	There is some reference to the legal and/or ethical impacts of the increased use of autonomous vehicles but the points made may not always be clear or well-explained.	1–2	No creditworthy material		0	6
Level	Description	Mark range																
3	There is a structured discussion of both the legal and ethical impacts of the increased use of autonomous vehicles.	5–6																
2	There is an explanation of the legal and/or ethical impacts of the increased use of autonomous vehicles. Answers may focus on only one aspect (legal or ethical) but clear and relevant points are made.	3–4																
1	There is some reference to the legal and/or ethical impacts of the increased use of autonomous vehicles but the points made may not always be clear or well-explained.	1–2																
No creditworthy material		0																

Qu	Part	Marking guidance	Total marks
06		<p>2 marks for AO1 (understanding)</p> <p>C The code is not translated using a compiler;</p> <p>E The code can directly manipulate computer registers;</p> <p>R. if more than two lozenges shaded</p>	2

Qu	Part	Marking guidance	Total marks
07	1	<p>Mark is for AO1 (recall)</p> <p>To convert / translate / change / turn assembly language into machine code;</p> <p>NE. convert/translate assembly language</p>	1

Qu	Part	Marking guidance	Total marks												
07	2	<p>4 marks for AO1 (understanding)</p> <table border="1" data-bbox="312 1050 1310 1823"> <thead> <tr> <th>Level</th> <th>Description</th> <th>Mark Range</th> </tr> </thead> <tbody> <tr> <td>2</td> <td> <p>At the upper end of the mark range the student will have shown a coherent and accurate explanation of how an interpreter works with clear references to the principles of operation.</p> <p>At the lower end of the mark range the student will have demonstrated a good understanding of how interpreters function.</p> </td> <td>3–4</td> </tr> <tr> <td>1</td> <td> <p>At the upper end of the mark range the student will have included some explanation of how an interpreter works though there may be key steps or elements either missing or described inaccurately.</p> <p>At the lower end of the mark range the student will have made one or two relevant statements but there may be errors or omissions in their understanding of how interpreters function.</p> </td> <td>1–2</td> </tr> <tr> <td colspan="2">No creditworthy material.</td> <td>0</td> </tr> </tbody> </table> <p>Indicative content</p> <ul style="list-style-type: none"> • Interpreters do not produce any machine code so the program needs to be translated each time it is executed. • They call machine code subroutines within their own code to carry out commands / directly execute the instruction. 	Level	Description	Mark Range	2	<p>At the upper end of the mark range the student will have shown a coherent and accurate explanation of how an interpreter works with clear references to the principles of operation.</p> <p>At the lower end of the mark range the student will have demonstrated a good understanding of how interpreters function.</p>	3–4	1	<p>At the upper end of the mark range the student will have included some explanation of how an interpreter works though there may be key steps or elements either missing or described inaccurately.</p> <p>At the lower end of the mark range the student will have made one or two relevant statements but there may be errors or omissions in their understanding of how interpreters function.</p>	1–2	No creditworthy material.		0	4
Level	Description	Mark Range													
2	<p>At the upper end of the mark range the student will have shown a coherent and accurate explanation of how an interpreter works with clear references to the principles of operation.</p> <p>At the lower end of the mark range the student will have demonstrated a good understanding of how interpreters function.</p>	3–4													
1	<p>At the upper end of the mark range the student will have included some explanation of how an interpreter works though there may be key steps or elements either missing or described inaccurately.</p> <p>At the lower end of the mark range the student will have made one or two relevant statements but there may be errors or omissions in their understanding of how interpreters function.</p>	1–2													
No creditworthy material.		0													

		<ul style="list-style-type: none">• Translating a line / statement at a time (rather than all at once) which it then executes.• If a runtime error is found the interpreter stops.	
--	--	---	--

Qu	Part	Marking guidance	Total marks
08		<p>2 marks for AO1 (understanding)</p> <ul style="list-style-type: none"> RAM is cheaper (per byte); Typically, the capacity of cache memory is not enough to store both data and programs. 	2

Qu	Part	Marking guidance	Total marks
09	1	<p>2 marks for AO1 (understanding)</p> <p>Maximum of two marks from:</p> <ul style="list-style-type: none"> enables user to access their data from more places/devices; enables user to more easily share data with others (can make parts of their cloud storage publicly available) // To allow sharing of files; increases the amount of potential storage available; reduced cost of computing devices for users as no need for as much built-in secondary storage // Can potentially purchase a cheaper (lower spec) computer; to allow concurrent access/collaboration; cloud storage is automatically backed up by the host; <p>R. Relative cost, unless statement is qualified.</p>	2

Qu	Part	Marking guidance	Total marks
09	2	<p>2 marks for AO2 (apply)</p> <p>Maximum of two marks from:</p> <p>SSDs are (relatively) expensive // have higher cost per (giga)byte; SSDs (typically) have lower capacity (than magnetic hard drives);</p> <p>2 marks if a valid point is made along with a suitable valid expansion</p> <p>A. magnetic hard drives (usually) have higher write/erase cycles (which can make them more suitable for hard disk recording, eg music, video) A. SSDs have limited write/erase cycles // SSDs degrade over time</p>	2

Qu	Part	Marking guidance	Total marks
10		<p>2 marks for AO2 (apply)</p> <p>16 000;;</p> <p>Maximum of one mark (if not fully correct) from:</p> <ul style="list-style-type: none"> multiplying by 1000 R. if 1024 used in place of 1000 multiplying by 8 multiplying by 2 	2

Qu	Part	Marking guidance	Total marks															
11		<p>2 marks for AO2 (apply)</p> <p>1 mark for each complete column with the correct values as below;</p> <table border="1" style="margin-left: 20px;"> <thead> <tr> <th>Character</th> <th>ASCII value</th> <th>Unicode value</th> </tr> </thead> <tbody> <tr> <td>w</td> <td>119</td> <td>119 // 77</td> </tr> <tr> <td>x</td> <td>120</td> <td>120 // 78</td> </tr> <tr> <td>y</td> <td>121</td> <td>121 // 79</td> </tr> <tr> <td>z</td> <td>122</td> <td>122 // 7A</td> </tr> </tbody> </table> <p>Note for examiner: award one mark for the Unicode column matching the ASCII column, even if incorrect ASCII values R. if any missing values</p> <p>R. Binary values in the Unicode column</p>	Character	ASCII value	Unicode value	w	119	119 // 77	x	120	120 // 78	y	121	121 // 79	z	122	122 // 7A	2
Character	ASCII value	Unicode value																
w	119	119 // 77																
x	120	120 // 78																
y	121	121 // 79																
z	122	122 // 7A																

Qu	Part	Marking guidance	Total marks
12		<p>3 marks for AO2 (apply)</p> <p>20;;;</p> <p>Maximum of two marks (if not fully correct) from:</p> <ul style="list-style-type: none"> • multiplying 8 x 10 (even if result is incorrect) // 80 shown in working; • multiplying by 2 // colour depth is 2; • dividing by 8; 	3

Qu	Part	Marking guidance	Total marks
13	1	<p>Mark is for AO1 (recall)</p> <p>(Sample resolution is the number of) bits per sample;</p>	1

Qu	Part	Marking guidance	Total marks
13	2	<p>Mark is for AO1 (understanding)</p> <p>Maximum of one mark from:</p> <ul style="list-style-type: none"> • larger file size/takes up more storage space; • sound files will take longer to download/transmit; • uses more memory/processing power (when recording); 	1

Qu	Part	Marking guidance	Total marks
13	3	<p>2 marks for AO2 (apply)</p> <p>4;;</p> <p>Maximum of one mark (if not fully correct) from:</p> <ul style="list-style-type: none"> • multiplying the three values (50, 40 000 and 2) together (even if result is incorrect); • division by 1000; • division by 1 000 000; 	2

Qu	Part	Marking guidance	Total marks
14	1	<p>Mark is for AO1 (recall)</p> <p>Maximum of one mark from:</p> <ul style="list-style-type: none"> • Bluetooth; • Near-field Communication/NFC; • IrDA/Infrared; • Zigbee; • Wireless USB; • Ultra-wideband/UWB; 	1

Qu	Part	Marking guidance	Total marks
14	2	<p>2 marks for AO1 (understanding)</p> <p>Maximum of two marks from:</p> <ul style="list-style-type: none"> • LANs cover relatively small geographical areas // WANs usually cover a wide geographic area; • LANs often owned and controlled/managed by a single person/organisation // WANs often under collective/distributed ownership; • WANs are (usually) several LANs connected together; • WANs (usually) have a much larger number of devices/users than LANs; • LAN has a lower latency // WAN has higher latency; • WANs are (usually) slower than LANs; • the cost-per-byte for transmission is much higher on a WAN; • LANs and WANs use different protocols; 	2

Qu	Part	Marking guidance	Total marks
14	3	<p>3 marks for AO1 (understanding)</p> <p>Maximum of three marks from:</p> <ul style="list-style-type: none"> • flexibility to expand network/add users/add own devices to the network; • there is no need to drill holes/install cabling; • mobility of user/devices; • modern devices are more likely to (be designed to) connect wirelessly; • guest access; • no trip hazards; <p>A. cost if valid explanation given</p>	3

Qu	Part	Marking guidance	Total marks
14	4	<p>Mark is for AO1 (recall)</p> <p>C SMTP;</p> <p>R. if more than one lozenge shaded</p>	1

Qu	Part	Marking guidance	Total marks
14	5	<p>2 marks for AO1 (recall)</p> <p>Maximum of two marks from:</p> <ul style="list-style-type: none"> • sending/receiving web pages; • using an encrypted connection // provides an encrypted version of HTTP; • more secure web transactions; • authentication of the website being visited; • encryption of the data between the server and the client; • reduces likelihood of man-in-the-middle attacks; 	2

Qu	Part	Marking guidance	Total marks
15	1	<p>2 marks for AO1 (understanding)</p> <p>Maximum of two marks from:</p> <ul style="list-style-type: none"> • (weak) passwords are easily cracked // a program could be used to try out lots of passwords // users might choose passwords which are not strong enough // (weak) passwords can be easily guessed; • usernames/passwords may have appeared in data leak; • (if users write down/store their passwords) these can be stolen; • susceptible to shouldering; • it is difficult to verify the actual identity of the person logging in (eg compared to fingerprint/Touch/facial recognition/Face ID, multi-factor authentication); 	2

Qu	Part	Marking guidance	Total marks
15	2	<p>2 marks for AO1 (understanding)</p> <p>1 mark for the method and 1 mark for a valid expansion.</p> <ul style="list-style-type: none"> • A code can be sent to your phone as a (text) message/in an email/as a pop-up to one of your devices; the user then types in the code (as well as the password); any hacker would need to access the phone as well as the password; • An authenticator app on a mobile phone; this generates a code which the user uses to complete the log-in; • Use two-factor authentication/2FA // strong customer/multi-factor authentication; this asks for a second form of identification such as something you know/possess/are; • Biometrics; (to be authenticated) reference data is compared to the individual's (unique) biometric data; • Smart cards/fobs; the user inserts a Smart Card to a reader and enters the PIN, the authentication request is then verified (using digital certificates); • Ask security / memorable question; the user is asked a question that only they know the answer to; 	2

Qu	Part	Marking guidance	Total marks
15	3	<p>2 marks for AO1 (understanding)</p> <p>Maximum of two marks from:</p> <ul style="list-style-type: none"> • A user may forget to do updates manually; • Automatic updates mean that a computer is protected more quickly; • Automatic updates from a trusted / known (secure) source will be safe // manual updates may be from an infected source; 	2

Qu	Part	Marking guidance	Total marks
16	1	<p>2 marks for AO1 (recall)</p> <p>Maximum one mark from:</p> <ul style="list-style-type: none"> the process of attempting to gain access to resources/a computer system; the practice of testing a computer system/network/web application // to test the effectiveness of security measures; <p>Maximum one mark from:</p> <ul style="list-style-type: none"> without knowledge of usernames/passwords/other normal means of access; to find vulnerabilities/weaknesses (that an attacker could exploit); 	2

Qu	Part	Marking guidance	Total marks
16	2	<p>2 marks for AO1 (recall)</p> <p>to simulate (an attack from) a (malicious) insider; who has knowledge of / basic credentials for the target system;</p>	2

Qu	Part	Marking guidance	Total marks
17	1	<p>2 marks for AO1 (understanding)</p> <p>Maximum of two marks from:</p> <ul style="list-style-type: none"> to reduce file size // to decrease the amount of storage needed; NE. Take up less space to make it faster to transmit/receive/read/write/access; (it could) save money if you use less bandwidth // (it could) save money if you use less storage capacity; to use less memory; NE. Take up less space 	2

Qu	Part	Marking guidance	Total marks
17	2	<p>2 marks for AO2 (apply)</p> <p>Maximum two marks from:</p> <ul style="list-style-type: none"> The data do not have a high frequency of consecutive repeating characters; The (compressed) data will take up more storage space/be longer than the original/uncompressed data; <p>2 marks if a valid point is made along with a suitable valid expansion</p>	2

Qu	Part	Marking guidance	Total marks
17	3	<p>Mark is for AO2 (apply)</p> <p>One mark for all characters in the correct position.</p> <pre> graph TD 11((11)) --- I[I] 11 --- 7((7)) 7 --- 3((3)) 7 --- S[S] 3 --- M[M] 3 --- P[P] </pre>	1

Qu	Part	Marking guidance	Total marks
18	1	<p>2 marks for AO1 (recall)</p> <p>A database with multiple tables; that are linked together // that reference each other;</p>	2

Qu	Part	Marking guidance	Total marks
18	2	<p>Mark is for AO1 (understanding)</p> <p>Maximum of one mark from:</p> <p>Reduces data redundancy; Reduces data inconsistency;</p>	1

Qu	Part	Marking guidance	Total marks
18	3	<p>Mark is for AO2 (apply)</p> <p>MemberID;</p> <p>I. case R. if quotation marks around response R. if obvious space(s) in response</p>	1

Qu	Part	Marking guidance	Total marks
18	4	<p>Mark is for AO2 (apply)</p> <p>MemberID;</p> <p>I. case R. if quotation marks around response R. if obvious space(s) in response</p>	1

Qu	Part	Marking guidance	Total marks
18	5	<p>6 marks for AO3 (program)</p> <p>Maximum of five marks if any errors</p> <p>1 mark: Three correct fields in one SELECT clause; 1 mark: one correct table in FROM clause; 1 mark: second correct table in same FROM clause; 1 mark: a correct condition in WHERE clause; 1 mark: correct conditions and correct usage of AND in WHERE clause // correct conditions and correct usage of ON with INNER JOIN; 1 mark: a correct ORDER BY clause;</p> <p>DPT. Use of incorrect key words when their versions are meaningful in the context of the question, eg GET instead of SELECT or use of AND instead of commas in FROM clause. DPT. Incorrect spelling of field names.</p> <p>A. Table names in front of field names provided the table names are correct A. == in place of = (for this year only)</p> <p>I. missing ASC in ORDER BY clause I. case and spacing R. missing quotes around 'Leader'</p> <p>Sample answer 1 SELECT FirstName, LastName, DatePresented FROM Member, Award WHERE Member.MemberID = Award.MemberID AND AwardName = 'Leader' ORDER BY DatePresented ASC</p> <p>Sample answer 2 SELECT FirstName, LastName, DatePresented FROM Member, Award WHERE Member.MemberID = Award.MemberID AND AwardID = 4 ORDER BY DatePresented ASC</p> <p>Sample answer 3 SELECT FirstName, LastName, DatePresented FROM Member INNER JOIN Award ON Member.MemberID = Award.MemberID WHERE AwardName = 'Leader' ORDER BY DatePresented ASC</p> <p>Sample answer 4 SELECT FirstName, LastName, DatePresented FROM Member INNER JOIN Award ON Member.MemberID = Award.MemberID WHERE AwardID = 4 ORDER BY DatePresented ASC</p>	6

Qu	Part	Marking guidance	Total marks
18	6	<p>2 marks for AO3 (program)</p> <p>Member; A. correct bracketed list of field identifiers after Member</p> <p>VALUES;</p> <p>I. case R. plural of Member R. singular of VALUES</p>	2