



Cambridge IGCSE™

CANDIDATE
NAME

--

CENTRE
NUMBER

--	--	--	--	--

CANDIDATE
NUMBER

--	--	--	--

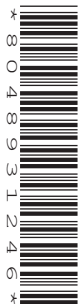

MATHEMATICS

0580/42

Paper 4 (Extended)

October/November 2021

2 hours 30 minutes

You must answer on the question paper.

You will need: Geometrical instruments

INSTRUCTIONS

- Answer **all** questions.
- Use a black or dark blue pen. You may use an HB pencil for any diagrams or graphs.
- Write your name, centre number and candidate number in the boxes at the top of the page.
- Write your answer to each question in the space provided.
- Do **not** use an erasable pen or correction fluid.
- Do **not** write on any bar codes.
- You should use a calculator where appropriate.
- You may use tracing paper.
- You must show all necessary working clearly.
- Give non-exact numerical answers correct to 3 significant figures, or 1 decimal place for angles in degrees, unless a different level of accuracy is specified in the question.
- For π , use either your calculator value or 3.142.

INFORMATION

- The total mark for this paper is 130.
- The number of marks for each question or part question is shown in brackets [].

This document has **20** pages. Any blank pages are indicated.

- 1 (a) Malena has 450 fruit trees.
The fruit trees are in the ratio apple : pear : plum = 8 : 7 : 3.

(i) Show that Malena has 200 apple trees.

[2]

(ii) Find the number of plum trees.

..... [1]

(iii) Malena wants to increase the number of pear trees by 32%.

Calculate the number of extra pear trees she needs.

..... [2]

(iv) Each apple tree produces 48.5 kg of apples.
The apples have an average mass of 165 g each.

Calculate the total number of apples produced by the 200 trees.
Give your answer correct to the nearest 1000 apples.

..... [3]

(b) Malena’s land is valued at three million and seventy-five thousand dollars.

(i) Write this number in figures.

..... [1]

(ii) Write your answer to **part (b)(i)** in standard form.

..... [1]

(c) In 2020, each plum tree produced 37.7 kg of plums.
This was 16% more than in 2019.

Calculate the mass of plums produced by each plum tree in 2019.

..... kg [2]

(d) Malena invests \$1800 at a rate of 2.1% per year compound interest.

Calculate the value of her investment at the end of 15 years.

\$ [2]

- 2 (a) The cumulative frequency diagram shows information about the floor area, $a \text{ m}^2$, of each of 80 houses.

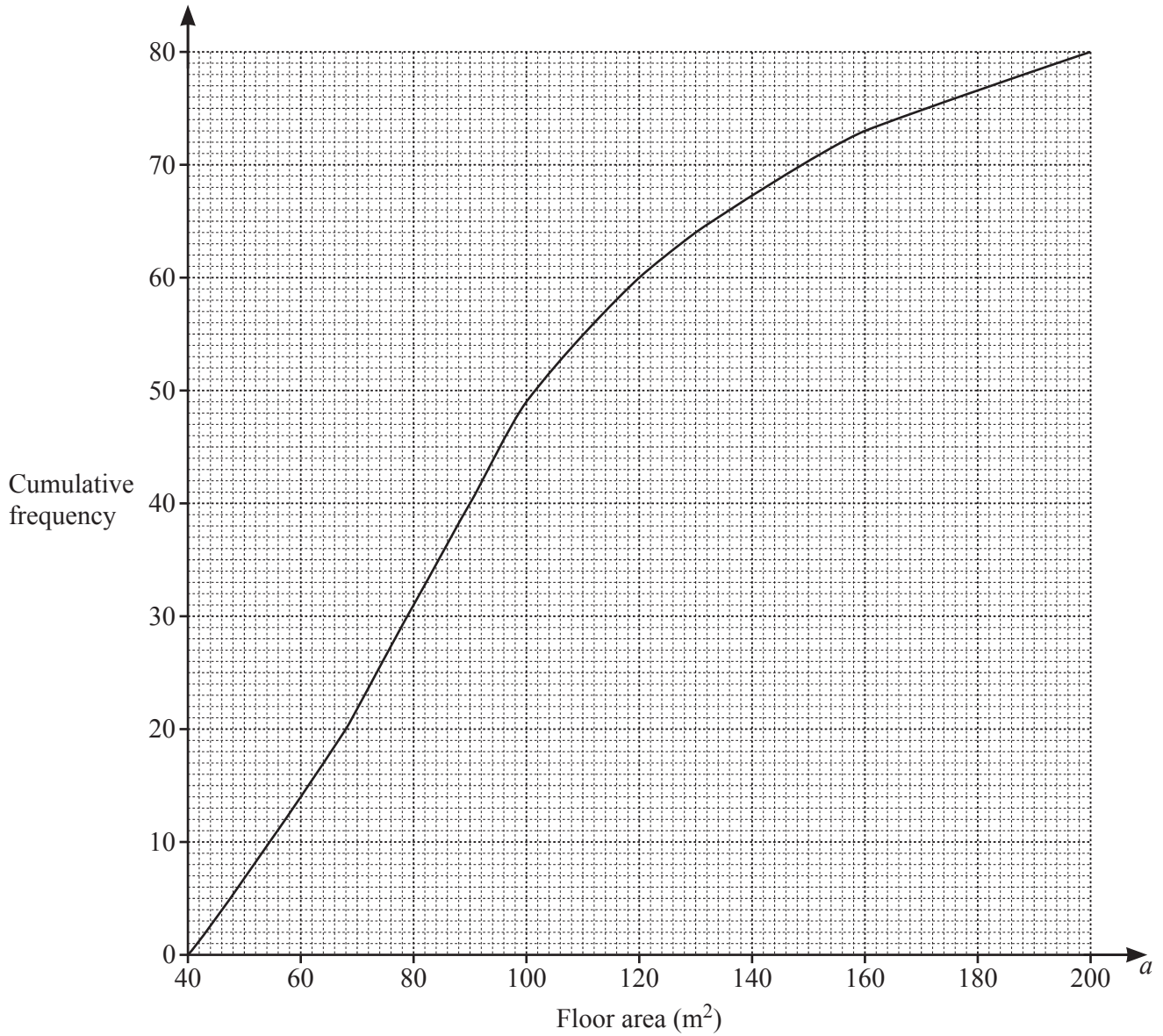

Use the diagram to find an estimate of

- (i) the median, m^2 [1]
- (ii) the lower quartile, m^2 [1]
- (iii) the interquartile range, m^2 [1]
- (iv) the number of houses with a floor area greater than 120 m^2 .
..... [2]

(b) The information about the 80 floor areas is shown in this frequency table.

Floor area ($a \text{ m}^2$)	$40 < a \leq 60$	$60 < a \leq 80$	$80 < a \leq 100$	$100 < a \leq 130$	$130 < a \leq 160$	$160 < a \leq 200$
Frequency	14	17	18	15	9	7

(i) Calculate an estimate of the mean floor area.

..... m^2 [4]

(ii) Complete the histogram to show the information in the frequency table.

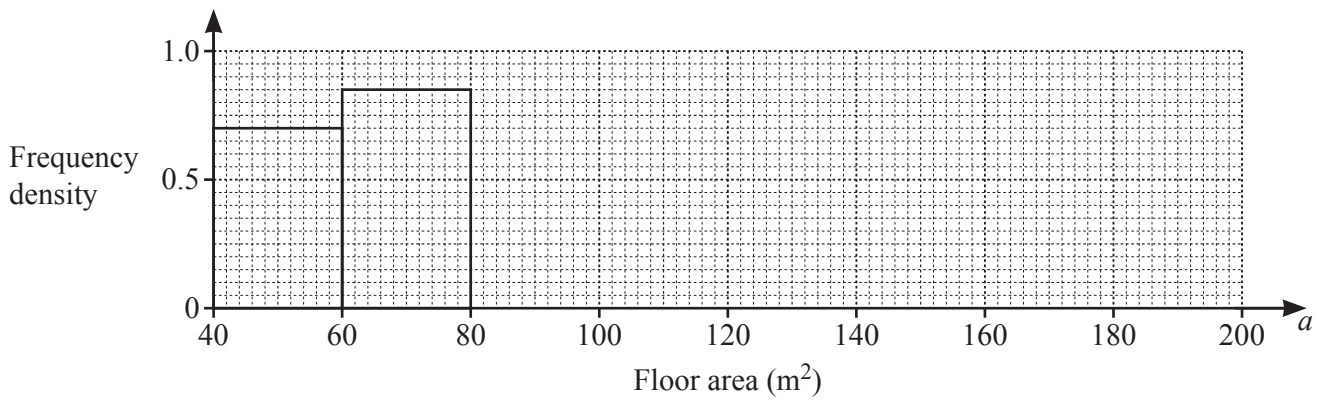

[4]

(iii) Two of the houses are picked at random.

Find the probability that one of the houses has a floor area greater than 130 m^2 and the other has a floor area 60 m^2 or less.

..... [3]

3 (a)

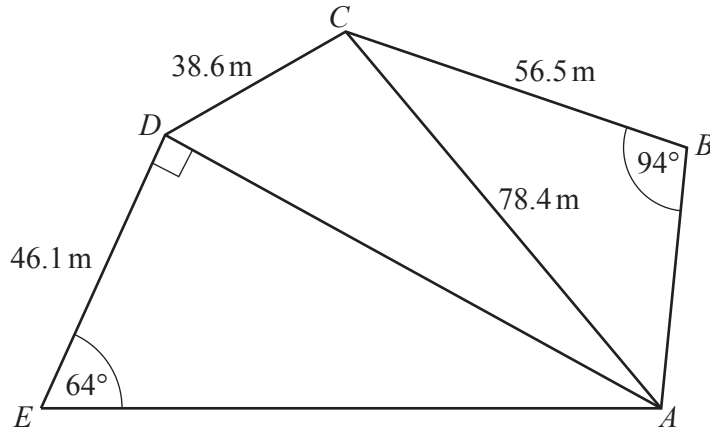
NOT TO
SCALE

$ABCDE$ is a pentagon.

- (i) Calculate AD and show that it rounds to 94.5 m, correct to 1 decimal place.

[2]

- (ii) Calculate angle BAC .

Angle $BAC = \dots\dots\dots$ [3]

- (iii) Calculate the largest angle in triangle CAD .

$\dots\dots\dots$ [4]

(b)

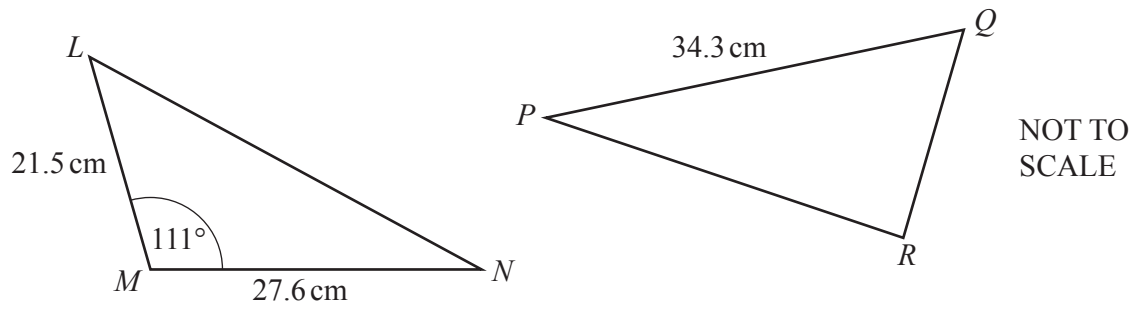

Triangle PQR has the same area as triangle LMN .

Calculate the shortest distance from R to the line PQ .

..... cm [3]

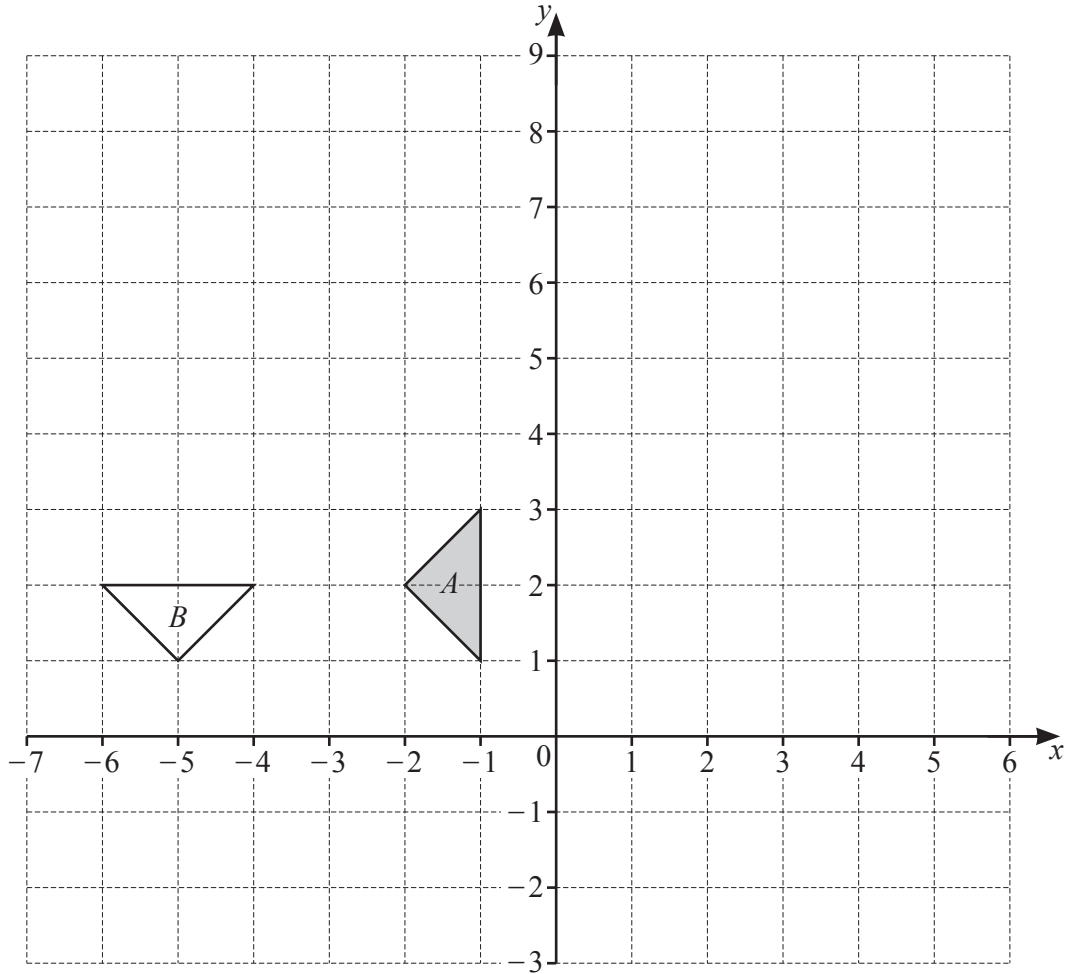

(a) On the grid, draw the image of triangle A after

(i) a translation by the vector $\begin{pmatrix} -4 \\ 5 \end{pmatrix}$, [2]

(ii) a reflection in the line $x = 1$, [2]

(iii) an enlargement, scale factor 2 and centre $(-5, -2)$. [2]

(b) Describe fully the **single** transformation that maps triangle A onto triangle B .

.....

..... [3]

5 The table shows some values for $y = x^3 - 3x^2 + 3$.

x	-1	-0.5	0	0.5	1	1.5	2	2.5	3
y		2.125	3	2.375	1		-1	-0.125	

(a) Complete the table. [3]

(b) On the grid, draw the graph of $y = x^3 - 3x^2 + 3$ for $-1 \leq x \leq 3$.

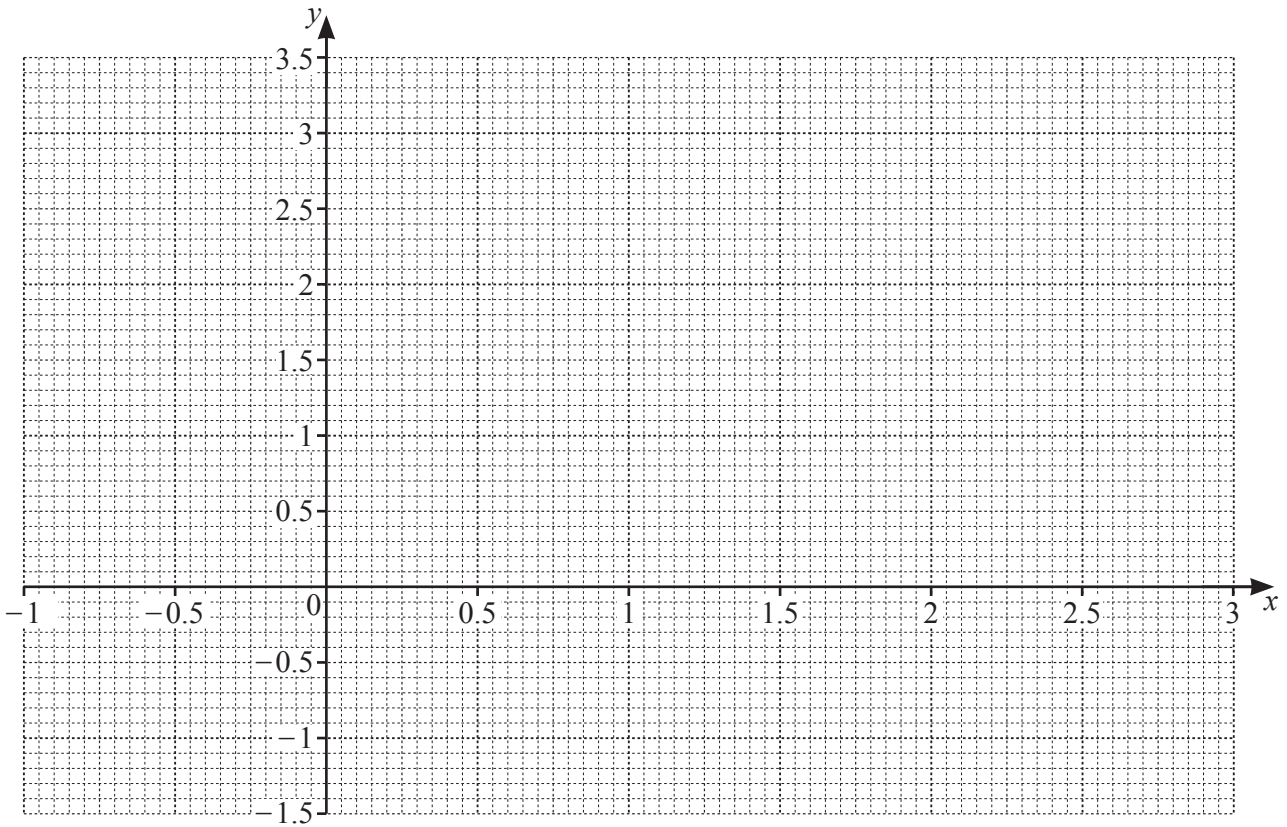

[4]

(c) By drawing a suitable straight line on the grid, solve the equation $x^3 - 3x^2 + x + 1 = 0$.

$x = \dots\dots\dots$ or $x = \dots\dots\dots$ or $x = \dots\dots\dots$ [4]

6 (a) Solve.

(i) $4(2x - 3) = 24$

$x = \dots\dots\dots$ [3]

(ii) $6x + 14 > 6$

$\dots\dots\dots$ [2]

(b) Rearrange the formula $V = 2x^3 - 3y^3$ to make y the subject.

$y = \dots\dots\dots$ [3]

(c) Show that $(2n - 5)^2 - 13$ is a multiple of 4 for all integer values of n .

[3]

(d) The expression $5 + 12x - 2x^2$ can be written in the form $q - 2(x + p)^2$.

(i) Find the value of p and the value of q .

$p = \dots\dots\dots$, $q = \dots\dots\dots$ [3]

(ii) Write down the coordinates of the maximum point of the curve $y = 5 + 12x - 2x^2$.

($\dots\dots\dots$, $\dots\dots\dots$) [1]

(e) The energy of a moving object is directly proportional to the square of its speed.
The speed of the object is increased by 30%.

Calculate the percentage increase in the energy of the object.

$\dots\dots\dots$ % [2]

- 7 (a) The diagram shows a container for storing grain.

The container is made from a hemisphere, a cylinder and a cone, each with radius 2 m. The height of the cylinder is 5.2 m and the height of the cone is h m.

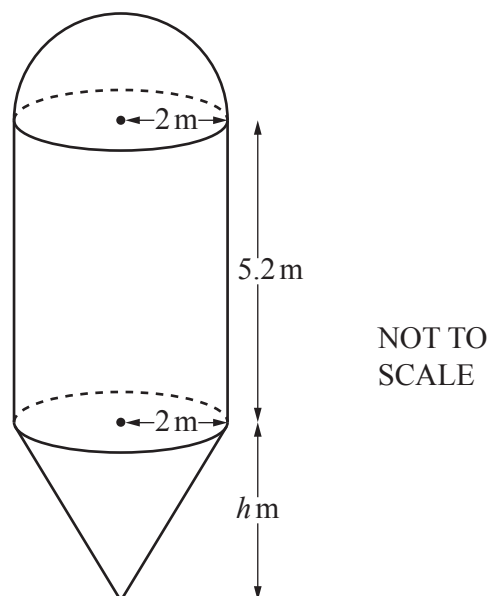

- (i) Calculate the volume of the hemisphere.
Give your answer as a multiple of π .

[The volume, V , of a sphere with radius r is $V = \frac{4}{3}\pi r^3$.]

..... m^3 [2]

- (ii) The total volume of the container is $\frac{88\pi}{3} \text{m}^3$.

Calculate the value of h .

[The volume, V , of a cone with radius r and height h is $V = \frac{1}{3}\pi r^2 h$.]

$h =$ [4]

- (iii) The container is full of grain.
 Grain is removed from the container at a rate of 35 000 kg per hour.
 1m³ of grain has a mass of 620 kg.

Calculate the time taken to empty the container.
 Give your answer in hours and minutes.

..... h min [3]

(b)

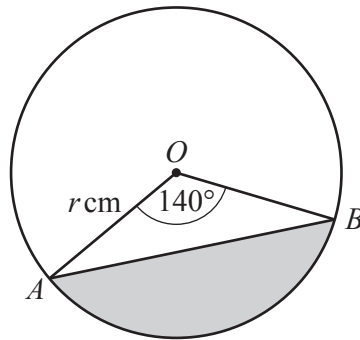

NOT TO
SCALE

A and B are points on a circle, centre O , radius $r \text{ cm}$.
 The area of the shaded segment is 65 cm^2 .

Calculate the value of r .

$r =$ [4]

8 (a) Kaito runs along a 12 km path at an average speed of x km/h.

(i) Write down an expression, in terms of x , for the number of hours he takes.

..... hours [1]

(ii) Yuki takes 1.5 hours longer to walk along the same path as Kaito.
She walks at an average speed of $(x - 4)$ km/h.

Write down an equation, in terms of x , and show that it simplifies to $x^2 - 4x - 32 = 0$.

[4]

(iii) Solve by factorisation.

$$x^2 - 4x - 32 = 0$$

$x = \dots\dots\dots$ or $x = \dots\dots\dots$ [3]

(iv) Find the number of hours it takes Yuki to walk along the 12 km path.

..... hours [2]

- (b) A bus travels 440 km, correct to the nearest 10 km.
The time taken to complete the journey is 6 hours, correct to the nearest half hour.

Calculate the lower bound of the speed of the bus.

..... km/h [3]

- 9 (a) F is the point $(5, -2)$ and $\overrightarrow{FG} = \begin{pmatrix} -2 \\ 3 \end{pmatrix}$.

Find

- (i) the coordinates of point G ,

(.....,) [1]

- (ii) $5\overrightarrow{FG}$,

$\begin{pmatrix} \\ \end{pmatrix}$ [1]

- (iii) $|\overrightarrow{FG}|$.

..... [2]

(b)

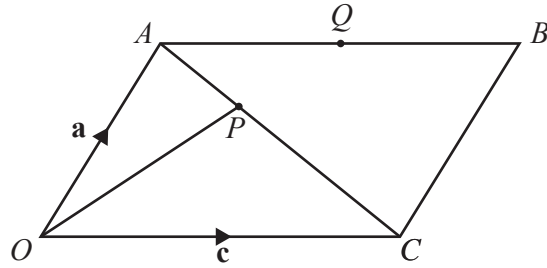

NOT TO SCALE

$OABC$ is a parallelogram.
 P is a point on AC and Q is the midpoint of AB .
 $\vec{OA} = \mathbf{a}$ and $\vec{OC} = \mathbf{c}$.

(i) Find, in terms of \mathbf{a} and/or \mathbf{c}

(a) \vec{AQ} ,

$\vec{AQ} = \dots\dots\dots$ [1]

(b) \vec{OQ} .

$\vec{OQ} = \dots\dots\dots$ [1]

(ii) $\vec{OP} = \frac{2}{3}\mathbf{a} + \frac{1}{3}\mathbf{c}$

(a) Show that O, P and Q lie on a straight line.

[2]

(b) Write down the ratio $OP : OQ$.
 Give your answer in the form $1 : n$.

$1 : \dots\dots\dots$ [1]

- 10 (a) Find the coordinates of the turning points of the graph of $y = x^3 - 12x + 6$.
You must show all your working.

(..... ,) and (..... ,) [5]

- (b) Determine whether each turning point is a maximum or a minimum.
Show how you decide.

[3]

11 (a)

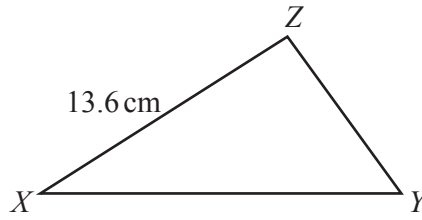
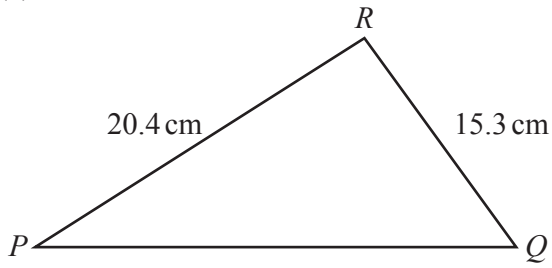

NOT TO SCALE

Triangle PQR is mathematically similar to triangle XYZ .

(i) Find YZ .

$YZ = \dots\dots\dots\text{ cm}$ [2]

(ii) The area of triangle XYZ is 63.6 cm^2 .

Calculate the area of triangle PQR .

$\dots\dots\dots\text{ cm}^2$ [3]

(b) Two containers are mathematically similar.
 The larger container has a capacity of 64.8 litres and a surface area of 0.792 m^2 .
 The smaller container has a capacity of 37.5 litres.

Calculate the surface area of the smaller container.

$\dots\dots\dots\text{ m}^2$ [3]

BLANK PAGE

Permission to reproduce items where third-party owned material protected by copyright is included has been sought and cleared where possible. Every reasonable effort has been made by the publisher (UCLES) to trace copyright holders, but if any items requiring clearance have unwittingly been included, the publisher will be pleased to make amends at the earliest possible opportunity.

To avoid the issue of disclosure of answer-related information to candidates, all copyright acknowledgements are reproduced online in the Cambridge Assessment International Education Copyright Acknowledgements Booklet. This is produced for each series of examinations and is freely available to download at www.cambridgeinternational.org after the live examination series.

Cambridge Assessment International Education is part of the Cambridge Assessment Group. Cambridge Assessment is the brand name of the University of Cambridge Local Examinations Syndicate (UCLES), which itself is a department of the University of Cambridge.