



Please write clearly in block capitals.

Centre number

--	--	--	--	--

Candidate number

--	--	--	--	--

Surname \_\_\_\_\_

Forename(s) \_\_\_\_\_

Candidate signature \_\_\_\_\_

I declare this is my own work.

# AS MATHEMATICS

Paper 1

Time allowed: 1 hour 30 minutes

**Materials**

- You must have the AQA Formulae for A-level Mathematics booklet.
- You should have a graphical or scientific calculator that meets the requirements of the specification.

**Instructions**

- Use black ink or black ball-point pen. Pencil should only be used for drawing.
- Fill in the boxes at the top of this page.
- Answer **all** questions.
- You must answer each question in the space provided for that question. If you need extra space for your answer(s), use the lined pages at the end of this book. Write the question number against your answer(s).
- Show all necessary working; otherwise marks for method may be lost.
- Do all rough work in this book. Cross through any work that you do not want to be marked.

**Information**

- The marks for questions are shown in brackets.
- The maximum mark for this paper is 80.

**Advice**

- Unless stated otherwise, you may quote formulae, without proof, from the booklet.
- You do not necessarily need to use all the space provided.

For Examiner's Use	
Question	Mark
1	
2	
3	
4	
5	
6	
7	
8	
9	
10	
11	
12	
13	
14	
15	
<b>TOTAL</b>	



Section A

Answer **all** questions in the spaces provided.

1 Find the coefficient of the  $x$  term in the binomial expansion of  $(3 + x)^4$

Circle your answer.

[1 mark]

12

27

54

108

2 Given that  $\frac{dy}{dx} = \frac{1}{x}$  find  $\frac{d^2y}{dx^2}$

Circle your answer.

[1 mark]

$-\frac{2}{x^2}$

$-\frac{1}{x^2}$

$\frac{1}{x^2}$

$\frac{2}{x^2}$



3 The graph of the equation  $y = \frac{1}{x}$  is translated by the vector  $\begin{bmatrix} 3 \\ 0 \end{bmatrix}$

3 (a) Write down the equation of the transformed graph. [1 mark]

$$y = \frac{1}{x-3}$$

---



---



---

3 (b) State the equations of the asymptotes of the transformed graph. [2 marks]

$$x = 3$$

$$y = 0$$

---



---



---



---



---

Turn over for the next question

Turn over ►



4 ABCD is a trapezium where A is the point (1, -2), B is the point (7, 1) and C is the point (3, 4)

DC is parallel to AB.

AD is perpendicular to AB.

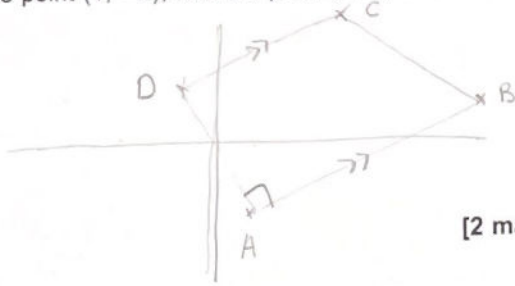

4 (a) (i) Find the equation of the line CD. [2 marks]

$$\text{gradient} = \frac{1 - -2}{7 - 1} = \frac{3}{6} = \frac{1}{2}$$

$$y - 4 = \frac{1}{2}(x - 3)$$

$$2y = x + 5$$

4 (a) (ii) Show that point D has coordinates (-1, 2) [3 marks]

$$\text{Gradient DA} = \frac{-1}{(1/2)} = -2$$

line AD:

$$y - -2 = -2(x - 1)$$

$$y + 2 = -2x + 2 \quad y = -2x$$

intersection between  $y = -2x$  and  $2y = x + 5$

$$-4x = x + 5 \quad x = -1$$

$$\text{sub } x \text{ into } y = -2x \quad y = -2(-1) \quad y = 2$$

$$(-1, 2)$$



4 (b) (i) Find the sum of the length of  $AB$  and the length of  $CD$  in simplified surd form.

[2 marks]

$$AB = \sqrt{6^2 + 3^2} = \sqrt{45} = 3\sqrt{5}$$

$$CD = \sqrt{4^2 + 2^2} = \sqrt{20} = 2\sqrt{5}$$

$$AB + CD = 5\sqrt{5}$$

4 (b) (ii) Hence, find the area of the trapezium  $ABCD$ .

[2 marks]

$$\frac{1}{2} (5\sqrt{5}) \times \text{length } AD$$

$$AD = \sqrt{2^2 + 4^2} = 2\sqrt{5}$$

$$\frac{1}{2} (5\sqrt{5})(2\sqrt{5})$$

$$= 25$$

Turn over ►



5 (a) Sketch the curve

$$y = (x - a)^2(3 - x) \quad \text{where } 0 < a < 3$$

indicating the coordinates of the points where the curve and the axes meet.

[4 marks]

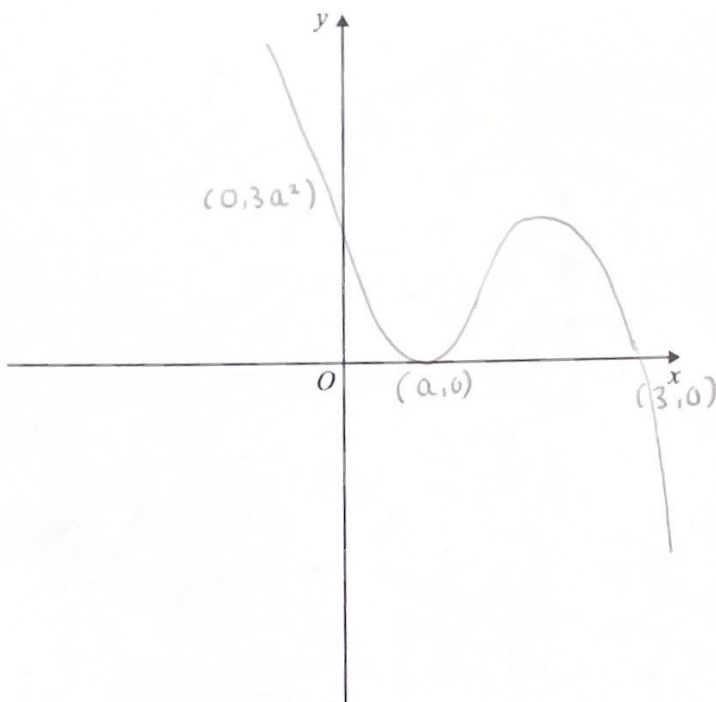

5 (b) Hence, solve

$$(x - a)^2(3 - x) > 0$$

giving your answer in set notation form.

[2 marks]

$x < a$

---

$a < x < 3$

---

$\{ x : 0 < x < 3, x \neq a \}$

---



---



6 A curve has the equation  $y = e^{-2x}$

At point  $P$  on the curve the tangent is parallel to the line  $x + 8y = 5$

Find the coordinates of  $P$  stating your answer in the form  $(\ln p, q)$ , where  $p$  and  $q$  are rational.

[7 marks]

$$y = e^{-2x}$$

$$\text{gradient} = -2e^{-2x}$$

$$\begin{aligned} \text{gradient of } x + 8y = 5 & \quad y = -\frac{1}{8}x + \frac{5}{8} \\ & = -\frac{1}{8} \end{aligned}$$

$$\text{so } P \text{ occurs when } -2e^{-2x} = -\frac{1}{8}$$

$$e^{-2x} = \frac{1}{16}$$

$$e^{2x} = 16$$

$$2x = \ln 16$$

$$x = \frac{1}{2} \ln 16$$

$$= \ln 4$$

$$y = e^{-2 \ln 4} \quad y = e^{-\ln 16} = \frac{1}{e^{\ln 16}}$$

$$y = \frac{1}{16}$$

$$P \text{ is } \left( \ln 4, \frac{1}{16} \right)$$

Turn over ▶



7 Scientists observed a colony of seabirds over a period of 10 years starting in 2010. They concluded that the number of birds in the colony, its population  $P$ , could be modelled by a formula of the form

$$P = a(10^{bt})$$

where  $t$  is the time in years after 2010, and  $a$  and  $b$  are constants.

7 (a) Explain what the value of  $a$  represents. [1 mark]

$a$  represents the initial population

---



---

7 (b) Show that  $\log_{10} P = bt + \log_{10} a$  [2 marks]

$P = a(10^{bt})$

$\log_{10} P = \log_{10}(a10^{bt})$

$\log_{10} P = \log_{10} a + \log_{10} 10^{bt}$

$= \log_{10} a + bt$

---



---

7 (c) The table below contains some data collected by the scientists.

Year	2013	2015
$t$	3	5
$P$	10200	12800
$\log_{10} P$	4.0086	4.1072

7 (c) (i) Complete the table, giving the  $\log_{10} P$  value to 5 significant figures. [1 mark]

---



---



---





7 (c) (ii) Use the data to calculate the value of  $a$  and the value of  $b$ .

[4 marks]

$$\text{using } \log_{10} P = bt + \log_{10} a$$

$$\textcircled{2} \quad 4.0086 = 3b + \log_{10} a$$

$$\textcircled{1} \quad 4.1072 = 5b + \log_{10} a$$

$$\textcircled{1} - \textcircled{2} = 2b = 0.0986 \quad b = 0.0493$$

$$4.0086 = 3(0.0493) + \log_{10} a$$

$$\log_{10} a = 3.8607$$

$$a = 7256$$

7 (c) (iii) Use the model to estimate the population of the colony in 2024.

[2 marks]

$$t = 14 \quad a = 7256 \quad b = 0.0493$$

$$P = 7256 (10^{14(0.0493)})$$

$$= 35555$$

Question 7 continues on the next page

Turn over ►



- 7 (d) (i) State an assumption that must be made in using the model to estimate the population of the colony in 2024.

[1 mark]

The value of constant  $b$  does not change  
after 2020

- 7 (d) (ii) Hence comment, with a reason, on the reliability of your estimate made in part (c)(iii).

[1 mark]

Not very reliable because its only based on  
data from 2 years



8 (a) (i) Show that the equation

$$3 \sin \theta \tan \theta = 5 \cos \theta - 2$$

is equivalent to the equation

$$(4 \cos \theta - 3)(2 \cos \theta + 1) = 0$$

[3 marks]

$$\text{using } \tan \theta = \frac{\sin \theta}{\cos \theta} \quad \frac{3 \sin^2 \theta}{\cos \theta} = 5 \cos \theta - 2$$

$$3 \sin^2 \theta = 5 \cos^2 \theta - 2 \cos \theta$$

$$\text{using } \sin^2 \theta + \cos^2 \theta = 1$$

$$3(1 - \cos^2 \theta) = 5 \cos^2 \theta - 2 \cos \theta$$

$$3 - 3 \cos^2 \theta = 5 \cos^2 \theta - 2 \cos \theta$$

$$8 \cos^2 \theta - 2 \cos \theta - 3 = 0$$

$$(4 \cos \theta - 3)(2 \cos \theta + 1) = 0$$

8 (a) (ii) Solve the equation

$$3 \sin \theta \tan \theta = 5 \cos \theta - 2$$

for  $-180^\circ \leq \theta \leq 180^\circ$

[2 marks]

$$4 \cos \theta = 3 \quad 2 \cos \theta = -1$$

$$\theta = \pm 41.4^\circ \quad \theta = \pm 120^\circ$$



8 (b) Hence, deduce all the solutions of the equation

$$3 \sin\left(\frac{1}{2}\theta\right) \tan\left(\frac{1}{2}\theta\right) = 5 \cos\left(\frac{1}{2}\theta\right) - 2$$

for  $-180^\circ \leq \theta \leq 180^\circ$ , giving your answers to the nearest degree.

[2 marks]

$$\frac{1}{2} \theta = \pm 41.4 \text{ and } \pm 120^\circ$$

$$\theta = \pm 83^\circ$$

Turn over for the next question

Turn over ►



9 A curve has equation

$$y = \frac{a}{\sqrt{x}} + bx^2 + \frac{c}{x^3} \quad \text{for } x > 0$$

where  $a$ ,  $b$  and  $c$  are positive constants.

The curve has a single turning point.

Use the second derivative of  $y$  to determine the nature of this turning point.

**You do not need to find the coordinates of the turning point.**

Fully justify your answer.

[7 marks]

$$y = ax^{-1/2} + bx^2 + cx^{-3}$$

$$\frac{dy}{dx} = -\frac{1}{2}ax^{-3/2} + 2bx - 3cx^{-4}$$

$$\frac{d^2y}{dx^2} = \frac{3}{4}ax^{-5/2} + 2b + 12cx^{-5}$$

$a, b, c$  are all positive

so each term will be positive

$$\frac{d^2y}{dx^2} > 0 \quad \text{so turning point is a minimum}$$



Section B

Answer **all** questions in the spaces provided.

10 Two forces  $\begin{bmatrix} 3 \\ -2 \end{bmatrix}$  N and  $\begin{bmatrix} -7 \\ -5 \end{bmatrix}$  N act on a particle.

Find the resultant force.

Circle your answer.

[1 mark]

$$\begin{bmatrix} -21 \\ 10 \end{bmatrix} \text{ N}$$

$$\begin{bmatrix} -4 \\ -7 \end{bmatrix} \text{ N}$$

$$\begin{bmatrix} 4 \\ 3 \end{bmatrix} \text{ N}$$

$$\begin{bmatrix} 10 \\ 7 \end{bmatrix} \text{ N}$$

11 Jackie says:

"A person's weight on Earth is directly proportional to their mass."

Tom says:

"A person's weight on Earth is different to their weight on the moon."

Only one of the statements below is correct.

Identify the correct statement.

Tick (✓) **one** box.

[1 mark]

Jackie and Tom are both wrong.

Jackie is right but Tom is wrong.

Jackie is wrong but Tom is right.

Jackie and Tom are both right.



12 A particle P lies at rest on a smooth horizontal table.  
A constant resultant force,  $F$  newtons, is then applied to P.

As a result P moves in a straight line with constant acceleration  $\begin{bmatrix} 8 \\ 6 \end{bmatrix} \text{ms}^{-2}$

12 (a) Show that the magnitude of the acceleration of P is  $10 \text{ms}^{-2}$  [1 mark]

$$\sqrt{8^2 + 6^2} = 10$$

---



---



---

12 (b) Find the speed of P after 3 seconds. [1 mark]

$$u = 0 \quad a = 10 \quad t = 3$$

$$v = 0 + 3(10) = 30 \text{ms}^{-1}$$

---



---



---

12 (c) Given that  $F = \begin{bmatrix} 2 \\ 1.5 \end{bmatrix} \text{N}$ , find the mass of P. [2 marks]

$$F = ma \quad \sqrt{2^2 + 1.5^2} = 2.5$$

$$2.5 = m \times 10$$

$$m = 0.25 \text{kg}$$

---



---



---



---



---

Turn over for the next question

Turn over ►



13 A car, initially at rest, is driven along a straight horizontal road.

The graph below is a simple model of how the car's velocity,  $v$  metres per second, changes with respect to time,  $t$  seconds.

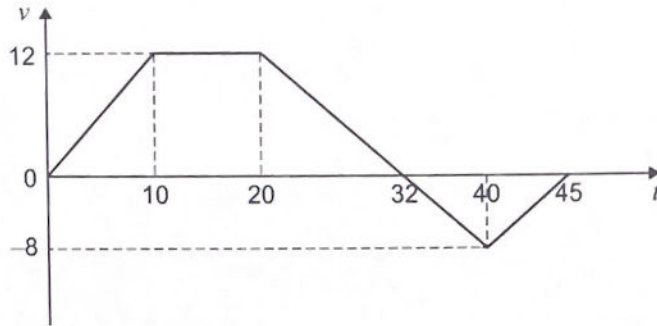

13 (a) Find the displacement of the car when  $t = 45$

[3 marks]

Area above axis:  $\frac{1}{2} (10 + 32) \times 12$   
 $= 252$

Area below axis =  $\frac{1}{2} (13)(8) = 52$

displacement =  $252 - 52 = 200\text{ m}$





13 (b) Shona says:

"This model is too simple. It is unrealistic to assume that the car will instantaneously change its acceleration."

On the axes below sketch a graph, for the first 10 seconds of the journey, which would represent a more realistic model.

[2 marks]

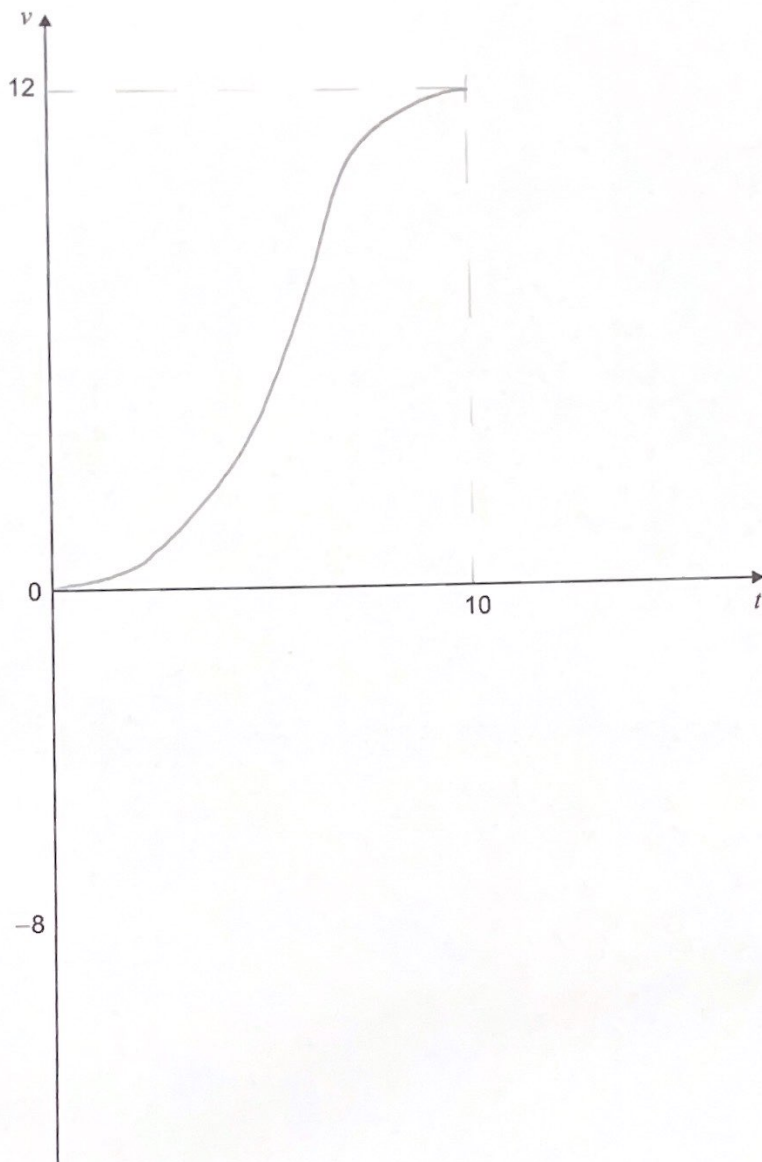

Turn over ▶



- 14 A particle, P, is moving along a straight line such that its acceleration  $a \text{ ms}^{-2}$ , at any time,  $t$  seconds, may be modelled by

$$a = 3 + 0.2t$$

When  $t = 2$ , the velocity of P is  $k \text{ ms}^{-1}$

- 14 (a) Show that the initial velocity of P is given by the expression  $(k - 6.4) \text{ ms}^{-1}$  [4 marks]

$$v = \int a \, dt$$

$$v = 3t + 0.1t^2 + c$$

when  $t = 2$ ,  $v = k$

$$k = 6 + \frac{2}{5} + c$$

$$c = k - 6.4$$

$$v = 3t + 0.1t^2 + k - 6.4$$

when  $t = 0$ ,  $v = c$ , aka initial velocity  
is  $(k - 6.4) \text{ ms}^{-1}$



14 (b) The initial velocity of P is one fifth of the velocity when  $t = 2$

Find the value of  $k$ .

[2 marks]

~~initial~~ initial  $\rightarrow 0.2k = k - 6.4$   
 $k = 8$

Turn over for the next question

Turn over ►



15

In this question, use  $g = 10 \text{ m s}^{-2}$

A box, B, of mass 4 kg lies at rest on a fixed rough horizontal shelf.

One end of a light string is connected to B.

The string passes over a smooth peg, attached to the end of the shelf.

The other end of the string is connected to particle, P, of mass 1 kg, which hangs freely below the shelf as shown in the diagram below.

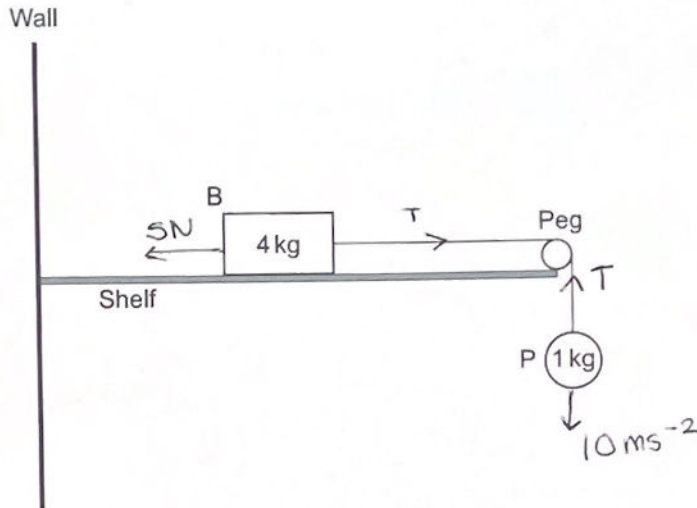

B is initially held at rest with the string taut.

B is then released.

B and P both move with constant acceleration  $a \text{ m s}^{-2}$

As B moves across the shelf it experiences a **total** resistance force of 5 N

15 (a)

State one type of force that would be included in the total resistance force.

[1 mark]

friction

---



---



---



15 (b) Show that  $a = 1$ 

[4 marks]

$$F = ma$$

$$P \rightarrow 10 - T = 1 \times a$$

$$10 - T = a$$

$$B \rightarrow T - 5 = 4 \times a$$

$$T - 5 = 4a$$

$$5 = 5a \quad a = 1$$

15 (c) When B has moved forward exactly 20 cm the string breaks.

Find how much further B travels before coming to rest.

[4 marks]

$$v^2 = u^2 + 2as$$

$$v^2 = 0 + 2(1)(0.2) = 0.4$$

$$F = ma \quad -5 = 4a \quad a = -1.25$$

$$0^2 = 0.4 + (2)(-1.25)s$$

$$s = 0.16m$$

$$s = 0.2m \text{ to } 1 \text{ s.f.}$$

Turn over ►



Do not write  
outside the  
box

---

---

---

---

---

---

---

---

---

---

---

---

---

---

---

---

---

---

---

---

---

---

---

15 (d) State one assumption **you** have made when finding your solutions in parts (b) or (c). [1 mark]

*The string remains parallel to the table.*

---

---

END OF QUESTIONS

