

Tuesday 5 November 2019 – Morning

GCSE (9–1) Mathematics

J560/04 Paper 4 (Higher Tier)

Time allowed: 1 hour 30 minutes

You may use:

- a scientific or graphical calculator
- geometrical instruments
- tracing paper

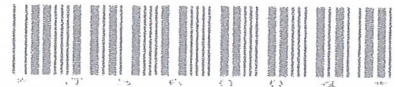

Please write clearly in black ink. **Do not write in the barcodes.**

Centre number

--	--	--	--	--

Candidate number

--	--	--	--

First name(s) _____

Last name _____

INSTRUCTIONS

- Use black ink. You may use an HB pencil for graphs and diagrams.
- Answer **all** the questions.
- Read each question carefully before you start to write your answer.
- Where appropriate, your answers should be supported with working. Marks may be given for a correct method even if the answer is incorrect.
- Write your answer to each question in the space provided.
- If additional space is required, use the lined page(s) at the end of this booklet. The question number(s) must be clearly shown.

INFORMATION

- The total mark for this paper is **100**.
- The marks for each question are shown in brackets [].
- Use the π button on your calculator or take π to be 3.142 unless the question says otherwise.
- This document consists of **20** pages.

Answer all the questions.

- 1 Carol makes birthday cards.
Each card takes the same amount of time to make.

She makes 3 cards in 48 minutes.
She has an order for 80 cards.

Can she complete this order in 3 days if she works 8 hours each day?
Show how you decide.

$$3 \text{ cards} = 48 \text{ minutes}$$

$$1 \text{ card} = 16 \text{ minutes}$$

$$80 \text{ cards} = 1280 \text{ minutes}$$

$$3 \text{ days } 8 \text{ hours per day} = 24 \text{ hours}$$

$$= 1440$$

Yes because it will take her 21.3 hours (1280 minutes) and she has 24 hours (1440 minutes) [5]

- 2 Use the formula $F = \frac{s}{\sqrt{tm}}$ to find the value of F when

$$s = 5.8 \times 10^6$$

$$t = 4.1 \times 10^8$$

$$m = 3.7 \times 10^{-2}$$

Give your answer in standard form, correct to 2 significant figures.

$$F = \frac{5.8 \times 10^6}{\sqrt{4.1 \times 10^8 \times 3.7 \times 10^{-2}}} = 1489.138881$$

$$= 1500$$

$$= 1.5 \times 10^3$$

..... 1.5×10^3 [4]

- 3 At a railway station, trains are either eastbound or westbound.
An eastbound train leaves the station every 25 minutes.
A westbound train leaves the station every 45 minutes.

An eastbound train and a westbound train both leave the station at 8 am.

When is the next time that two trains leave the station together?

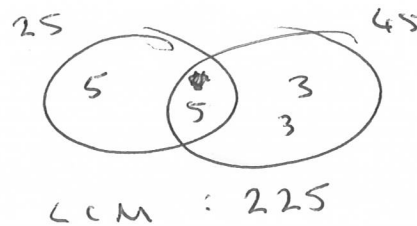

..... 12.45 am [4]

- 4 Bob makes dry concrete by mixing cement, sand and stone in the ratio 1 : 2 : 3 by weight. He buys the cement, sand and stone in bags as shown in this table.

	Weight of bag (kg)	Cost per bag (£)
Cement	25	5.50
Sand	20	2.00
Stone	15	3.90

He packs the dry concrete into 30kg bags.

Bob buys just enough cement, sand and stone to make 50 bags of dry concrete.

- (a) Show that Bob buys 500kg of sand.

[3]

$$30 \div (1 + 2 + 3) = 5$$

1 bag : 5 kg cement, 10 kg sand, 15 kg stone } $\times 50$
 50 bags : 250 kg, 500 kg, 750 kg

- (b) Bob sells the 50 bags of dry concrete for a total of £396.

Calculate Bob's percentage profit.

Cement: $250 \div 25 = 10$ bags

sand: $500 \div 20 = 25$ bags

stone: $750 \div 15 = 50$ bags

$$10 \times 5.5 + 25 \times 2 + 50 \times 3.9 = 300$$

$$\frac{396 - 300}{300} \times 100 = 32\%$$

(b) 32 % [5]

- 5 Multiply out and simplify.

$$(4x + y)(x - 3y)$$

$$4x^2 - 12xy + xy - 3y^2$$

$$4x^2 - 11xy - 3y^2 \dots\dots\dots [3]$$

- 6 A bag of sweets contains only mints, sherberts and toffees.

The ratio of the number of mints to sherberts is 2 : 3.

The ratio of the number of sherberts to toffees is 7 : 5.

What fraction of the sweets are sherberts?

$$\begin{array}{l} M : S : T \\ 2 : 3 \quad \times 7 \\ \quad \quad 7 : 5 \quad \times 3 \end{array}$$

find a common multiple for sherberts

$$\begin{array}{l} 14 : 21 \\ \textcircled{21} : 15 \end{array}$$

$$\frac{21}{14 + 21 + 15} = \frac{21}{50}$$

$$\dots\dots\dots \frac{21}{50} \dots\dots\dots [3]$$

- 7 12 students take two tests.
Each test is out of 60.
The scatter diagram shows the results for 10 of the students.

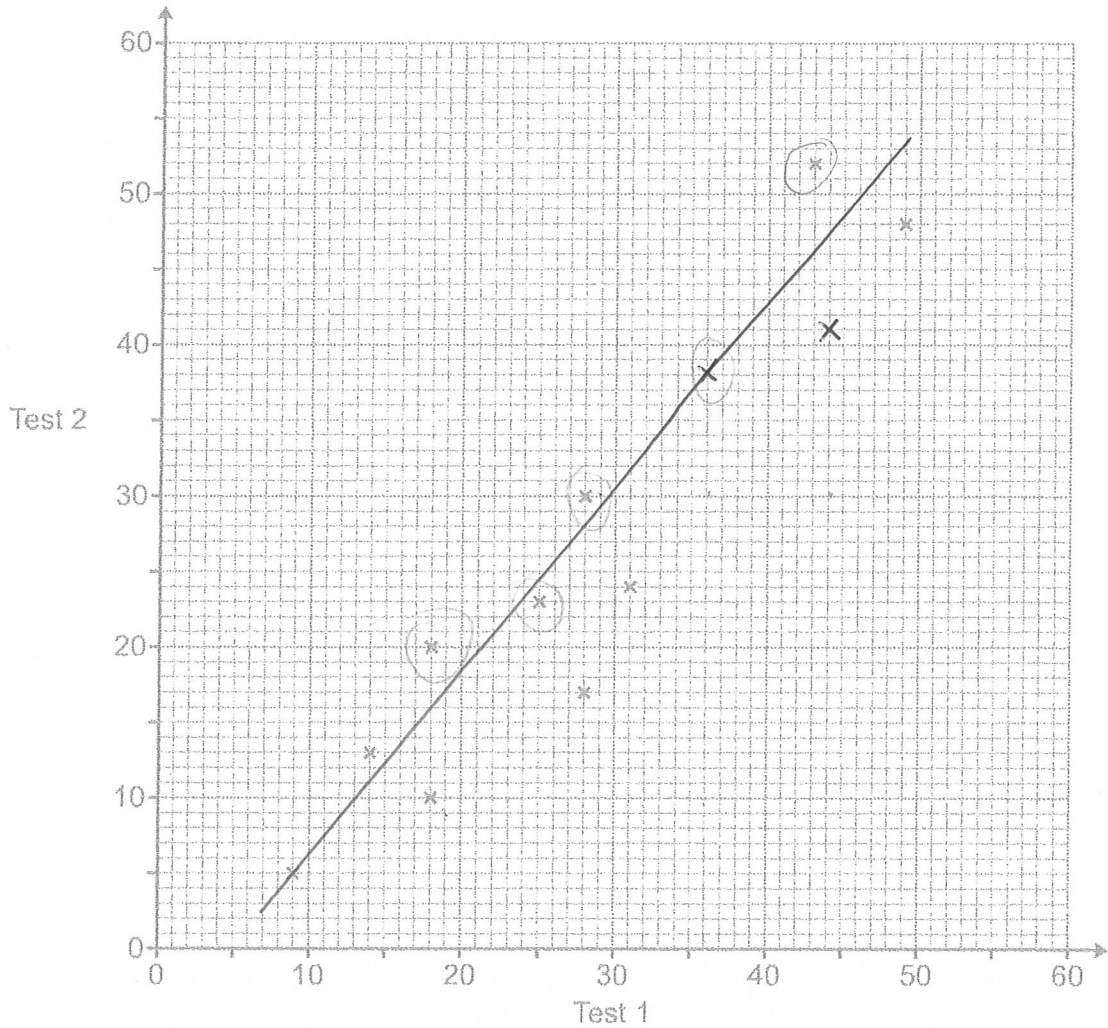

- (a) The table shows the results for the other 2 students.

Test 1	36	38
Test 2	44	41

Plot these results on the scatter diagram.

[1]

- (b) Describe the type of correlation shown in the scatter diagram.

(b) positive [1]

(c) (i) Draw a line of best fit on the scatter diagram.

[1]

(ii) Another student was absent for Test 2.
The student scored 40 marks on Test 1.

Use your line of best fit to estimate a result for this student on Test 2.

(c)(ii) 43 [1]

(d) Work out the percentage of **the 12 students** whose result on Test 1 is **lower** than their result on Test 2.

$$\frac{5}{12} \times 100 = 41.7$$

(d) 42 % [4]

- 8 The diagrams show the price paid by two groups of people visiting a funfair.

5 adults	£	
4 children	£	
Total £		78

3 adults	£	
6 children	£	
Total £		63

Assume each adult pays the same price and each child pays the same price.

Find the price for an adult and the price for a child.

adults - A

Children - C

$$5A + 4C = 78 \quad \times 6$$

$$3A + 6C = 63 \quad \times 4$$

$$30A + 24C = 468 \quad -$$

$$12A + 24C = 252$$

$$18A = 216$$

$$A = 12$$

$$5 \times 12 + 4C = 78$$

$$4C = 18$$

$$C = 4.5$$

Adult price = £ 12

Child price = £ 4.50

[5]

9 Here is function A.



- (a) A number, k , is input into function A.
The output is also k .

Find the value of k .

$$3(k-4) = k$$

$$3k - 12 = k$$

$$2k = 12$$

$$k = 6$$

(a) $k = \dots\dots\dots 6 \dots\dots\dots$ [3]

- (b) The output of function A is y .

Write an algebraic expression, in terms of y , for the input of function A.

(b) $\dots\dots\dots \frac{y}{3} + 4 \dots\dots\dots$ [2]

- (c) The diagram shows a composite function with an input, n , and an output of 96.

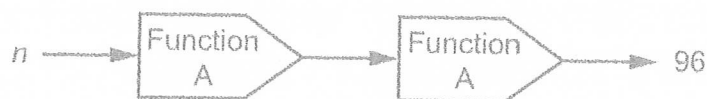

Find the value of n .

$$3(3(n-4)-4) = 96$$

$$3(3n - 16) = 96$$

$$3n - 16 = 32$$

$$3n = 48$$

$$n = 16$$

(c) $n = \dots\dots\dots 16 \dots\dots\dots$ [2]

10 The value of a house, £ H , is given by the formula

$$H = 165000 \times 1.03^t$$

where t is the number of years after 1st January 2010.

(a) Write down the value of the house on 1st January 2010.

(a) £ 165000 [1]

(b) Write down the annual percentage increase in the value of the house.

(b) 3 % [1]

(c) Show that the value of the house is over £200 000 on 1st January 2017. [2]

$$165000 \times 1.03^7 = 202929.1878$$

$$202929.1878 > 200000$$

- 11 (a) Are these two triangles definitely congruent?
Give a reason.

Not to scale

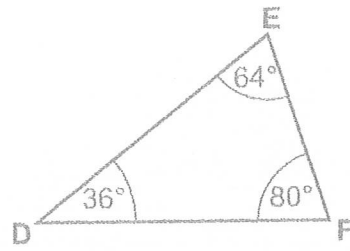
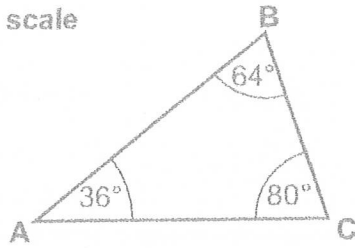

NO because lengths are unknown, so can't say for certain that the triangles are congruent

[1]

- (b) Prove that these two triangles are congruent.

Not to scale

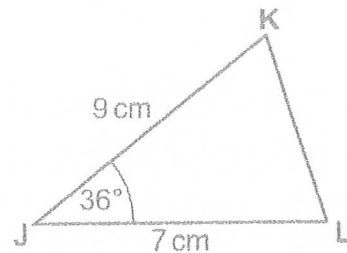
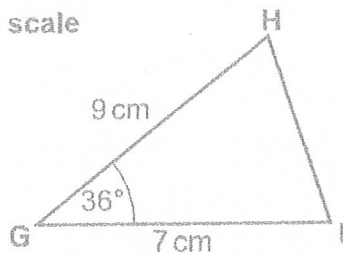

$$\angle IGH = \angle LJK \quad (\text{angle})$$

$$GH = JK \quad (\text{side})$$

$$GI = JL \quad (\text{side})$$

[3]

- 12 The cumulative frequency graph summarises the annual salary, p (£ thousands), of the 60 workers in a factory.

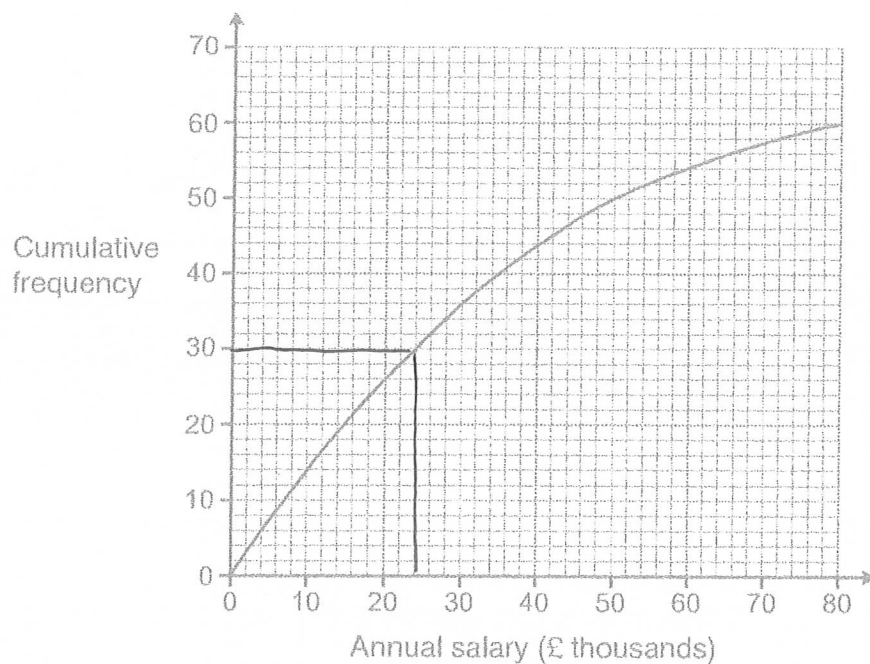

- (a) Use the graph to estimate the median annual salary.

(a) £24..... thousands [1]

- (b) Complete this cumulative frequency table.

Annual salary, p (£ thousands)	Cumulative frequency
$p \leq 10$	14
$p \leq 20$	26
$p \leq 30$	36
$p \leq 50$	50
$p \leq 80$	60

[2]

- (c) Use the information in the cumulative frequency table to calculate an estimate of the mean annual salary.

Interval	midpoint x	frequency f	fx
$0 \leq p < 10$	5	14	70
$10 \leq p < 20$	15	12	180
$20 \leq p < 30$	25	10	250
$30 \leq p < 50$	40	14	560
$50 \leq p < 80$	65	10	650
		60	1710
		\downarrow Σf	\downarrow Σfx

$$\text{Mean} = \frac{\Sigma fx}{\Sigma f} = \frac{1710}{60} = 28.5$$

(c) £ 28.5 thousands [5]

- (d) Explain why your estimate of the median is more reliable than your estimate of the mean.

..... the figures used in the mean calculation.....
 are an approximate..... [1]

- 13 (a) A transport lorry consists of a cab and a trailer.
The trailer has a volume of 90m^3 .
Alfie makes a model of this lorry using a scale of 1 : 72.

Work out the volume of the trailer in Alfie's model, giving your answer in cm^3 .

$$90 \div 72^3 \times 100^3 = 241.13$$

(a) 241.13 cm^3 [3]

- (b) Alfie paints his model lorry.
He has eight colours available.

He decides to paint the cab in one colour and the trailer in a different colour.

He then wants to paint his name on the trailer.
The name must be in a different colour to the trailer.

In how many different ways can Alfie paint his model lorry?

$$8 \times 7 \times 7 = 392$$

(b) 392 [3]

- 14 The diagram shows a circle with centre $(0, 0)$ and a tangent at the point $(-12, 16)$.

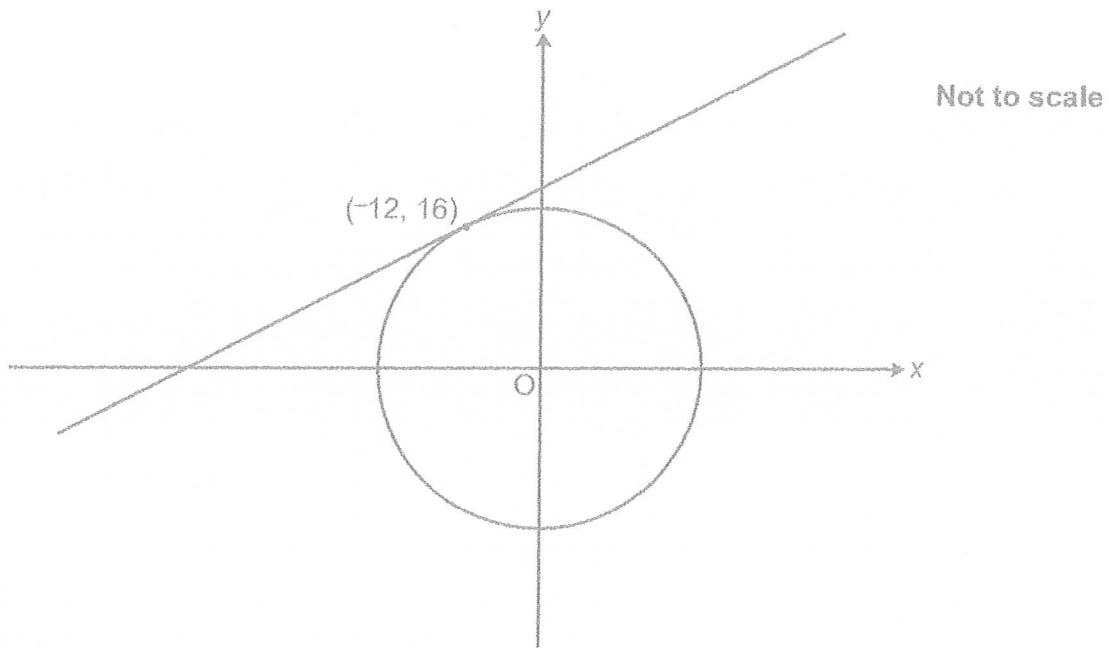

The tangent crosses the y -axis at the point $(0, p)$.

Find the value of p .

$$\text{gradient of radius} = -\frac{16}{12} = -\frac{4}{3}$$

$$\text{gradient of tangent} = \frac{3}{4}$$

$$y = \frac{3}{4}x + c$$

$$16 = \frac{3}{4}(-12) + c \rightarrow c = 25$$

$$p = \dots 25 \dots [5]$$

- 15 (a) Calculate length DF in this triangle.

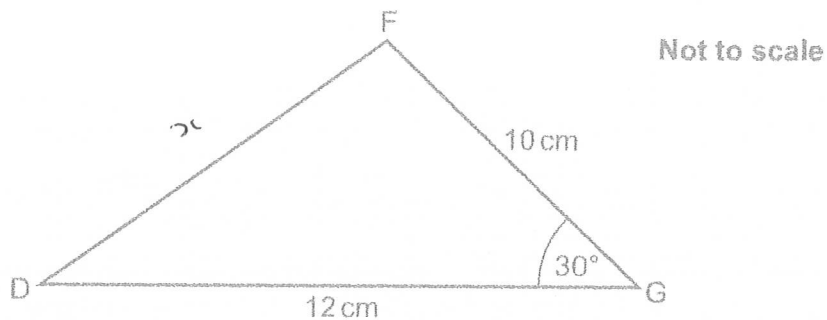

~~$$\frac{x}{\sin 30} =$$~~

$$x^2 = 10^2 + 12^2 - 2 \times 10 \times 12 \cos 30$$

$$x^2 = 244 - 240 \cos 30$$

$$x^2 = 36.15 \dots$$

$$x = 6.01$$

(a) 6.01 cm [3]

- (b) Calculate angle ACB in this triangle.

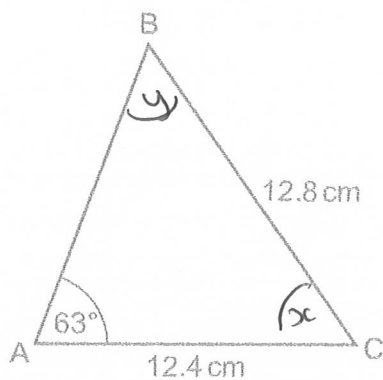

Not to scale

$$\frac{\sin y}{12.4} = \frac{\sin 63}{12.8}$$

$$y = \sin^{-1} \left(\frac{12.4 \sin 63}{12.8} \right) = 59.67$$

$$x = 180 - 63 - 59.67 = 57.33$$

(b) 57.33 ° [4]

- 16 Show that $\frac{x+9}{x^2-1} + \frac{4}{x+1}$ can be written in the form $\frac{a}{x-1}$, where a is an integer. [4]

$$\frac{x+9}{(x-1)(x+1)} + \frac{4(x-1)}{(x+1)(x-1)}$$

$$\frac{5x+5}{(x-1)(x+1)} = \frac{5(x+1)}{(x-1)(x+1)}$$

- 17 Sketch the graph of $y = 3^x$.
Give the value of the y -intercept. [2]

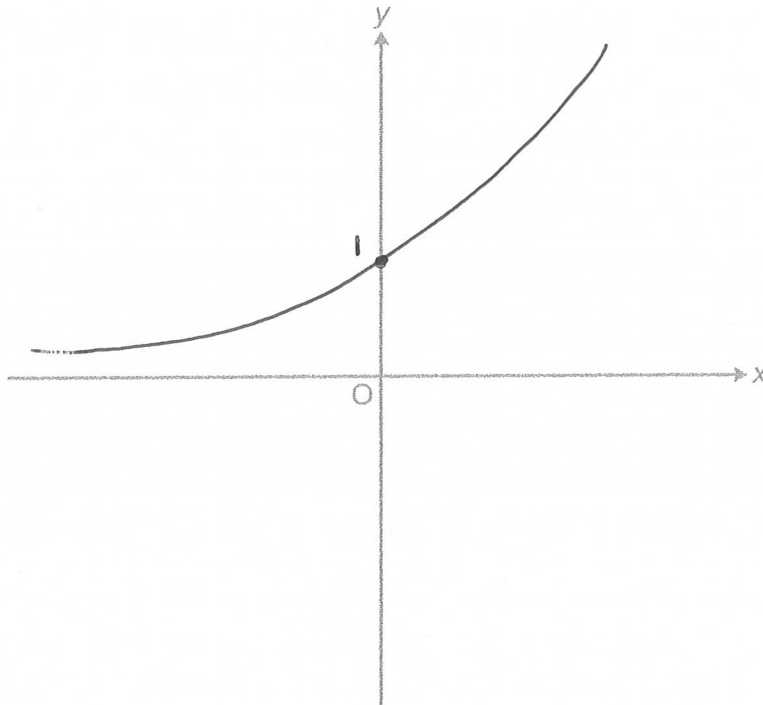

18 The diagram shows a right-angled triangular prism ABCDEF.

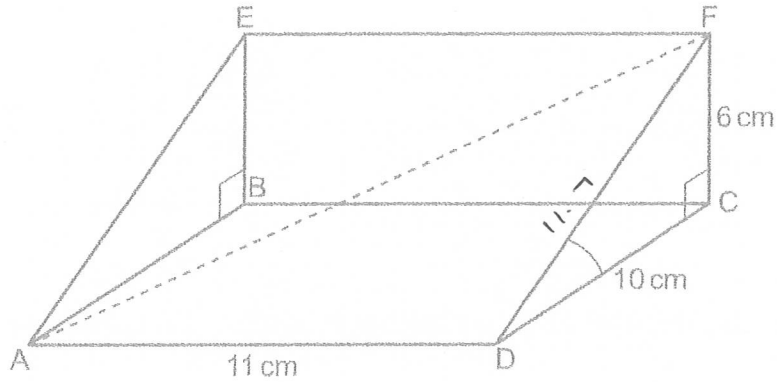

Length AD = 11 cm, length CD = 10 cm and length CF = 6 cm.

(a) Calculate the volume of the prism.

$$\frac{6 \times 10}{2} \times 11 = 330$$

(a) cm³ [2]

(b) Use trigonometry to show that angle FDC = 31°, correct to the nearest degree. [2]

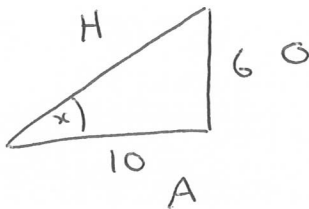

$$\tan x = \frac{6}{10}$$

$$x = \tan^{-1}\left(\frac{6}{10}\right) = 30.963\dots$$

$$= 31^\circ$$

(c) Calculate the exact length of AF.

$$\sqrt{6^2 + 10^2} = 11.66\dots$$

$$\sqrt{11^2 + 11.66^2} = \sqrt{257} = 16.03$$

(c) $\sqrt{257}$ cm [4]

↑ exact

19 The graph shows the distance travelled by a particle over 8 seconds.

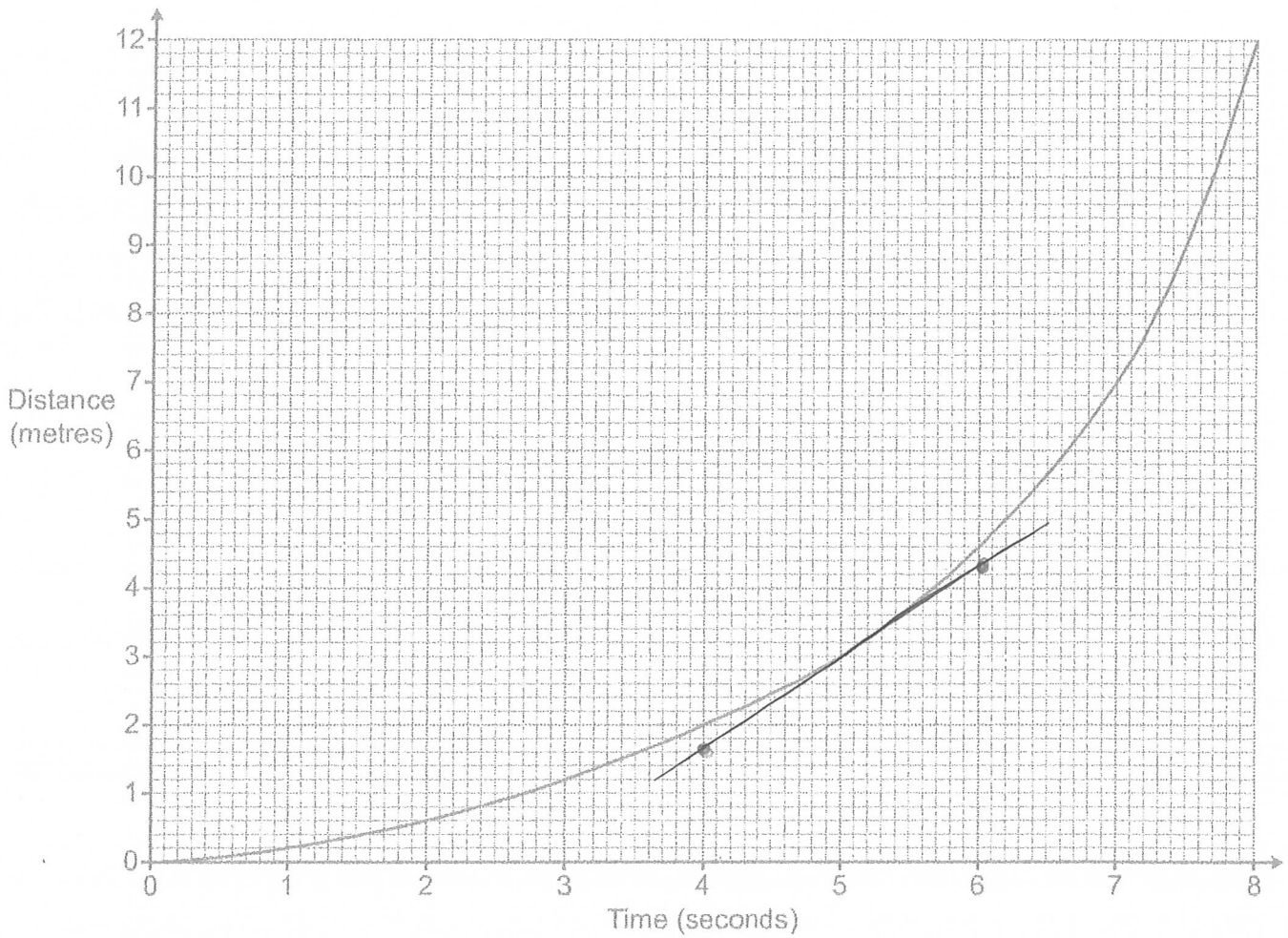

Estimate the speed of the particle at 5 seconds.

$$\text{speed} = \frac{4.4 - 1.8}{2} = 1.3$$

..... 1.3 m/s [4]

END OF QUESTION PAPER

ADDITIONAL ANSWER SPACE

If additional space is required, you should use the following lined page(s). The question number(s) must be clearly shown in the margin(s).

A large rectangular area with a vertical line on the left side and horizontal dotted lines across the rest of the page, intended for writing answers.



Copyright Information

OCR is committed to seeking permission to reproduce all third-party content that it uses in its assessment materials. OCR has attempted to identify and contact all copyright holders whose work is used in this paper. To avoid the issue of disclosure of answer-related information to candidates, all copyright acknowledgements are reproduced in the OCR Copyright Acknowledgements Booklet. This is produced for each series of examinations and is freely available to download from our public website (www.ocr.org.uk) after the live examination series. If OCR has unwittingly failed to correctly acknowledge or clear any third-party content in this assessment material, OCR will be happy to correct its mistake at the earliest possible opportunity.

For queries or further information please contact The OCR Copyright Team, The Triangle Building, Shaftesbury Road, Cambridge CB2 8EA.

OCR is part of the Cambridge Assessment Group; Cambridge Assessment is the brand name of University of Cambridge Local Examinations Syndicate (UCLES), which is itself a department of the University of Cambridge.