

Similar Shapes (Higher)

Please write clearly in block capitals

Forename:

Surname:

Materials

For this paper you must have:

- mathematical instruments



You **can** use a calculator.

Instructions

- Use black ink or black ball-point pen. Draw diagrams in pencil.
- Fill in the boxes at the top of this page.
- Answer all questions.
- You must answer the questions in the spaces provided. Do not write outside the box around each page or on blank pages.
- Do all rough work in this book. Cross through any work you do not want to be marked.

Information

- The marks for questions are shown in brackets.
- You may ask for graph paper, tracing paper and more answer paper. These must be tagged securely to this answer book.

Advice

- In all calculations, show clearly how you work out your answer.

- 1 A delivery company uses two mathematically similar cardboard boxes.
The height of the smaller cuboid box is x .
The volume of the larger box is **8 times** that of the smaller box.

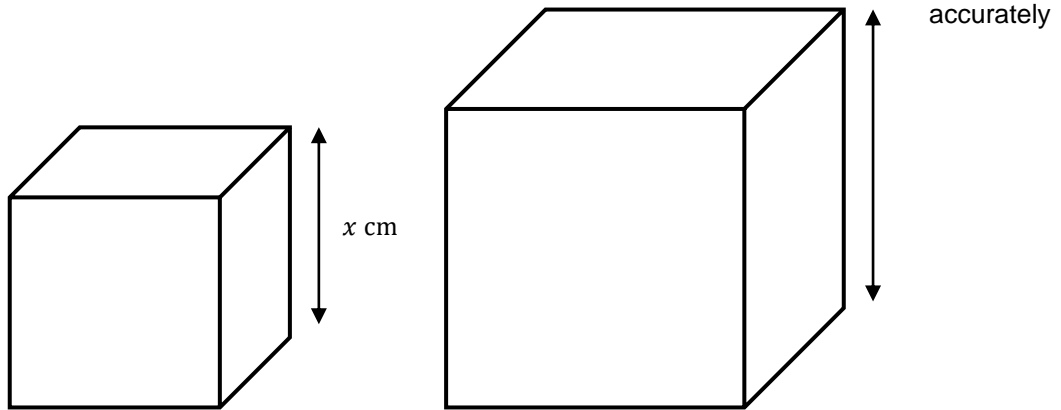

Find the height of the larger box .
Give your answer in terms of x .

[4 marks]

Answer _____

Turn over for next question

- 2 Two mathematically similar wooden door wedges are shown below
 The height of the smaller wedge is 6 cm and the width is 9 cm
 The height of the larger wedge is 12 cm and the base is 16 cm

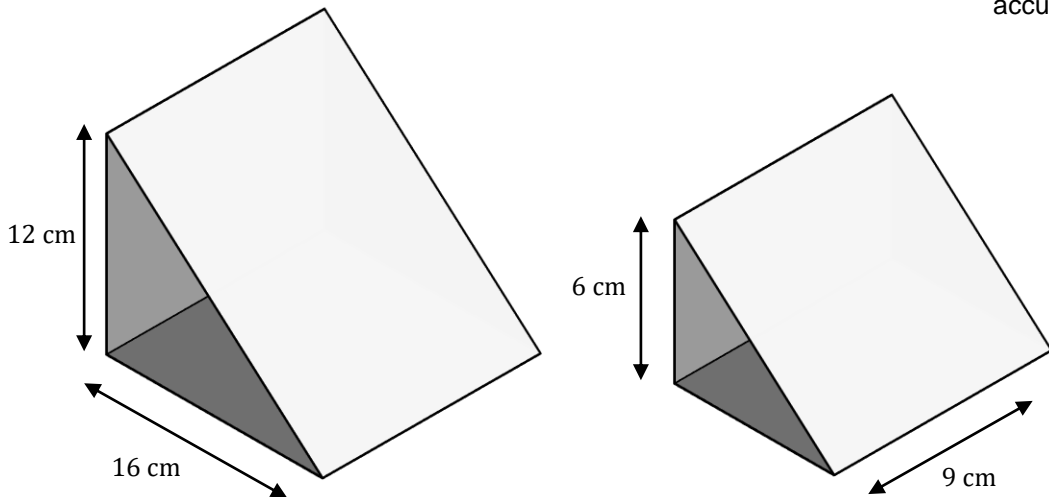

Find the volume of the smaller door wedge.

[3 marks]

Answer _____

Turn over for next question

- 3 The diagram below shows a solid shape, with a section cut from the centre.
 This section is mathematically similar to the original solid.
 The scale factor of the larger shape to the smaller shape is 0.5

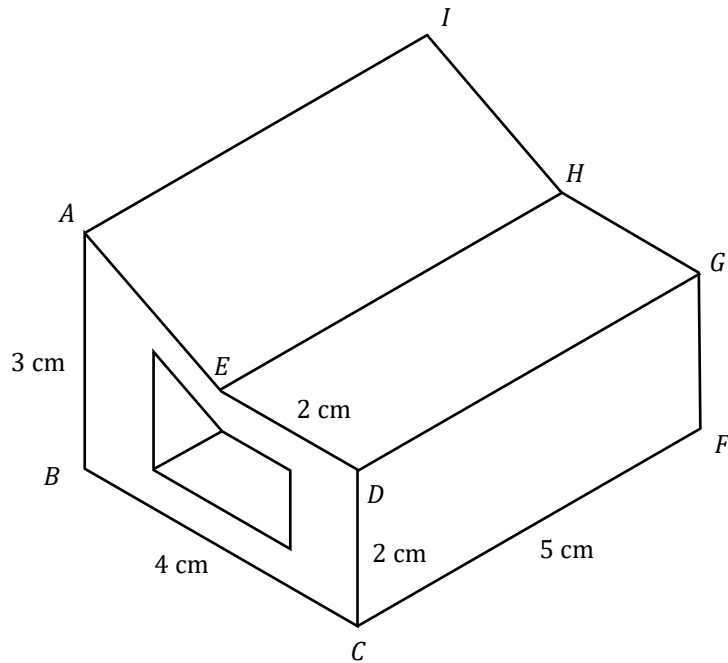

Not drawn accurately

Calculate the volume of the shape shown above.
 Give your answer to 3 significant figures.

[5 marks]

Answer _____

Turn over for next question

- 4 Two mathematically similar spheres are shown below.

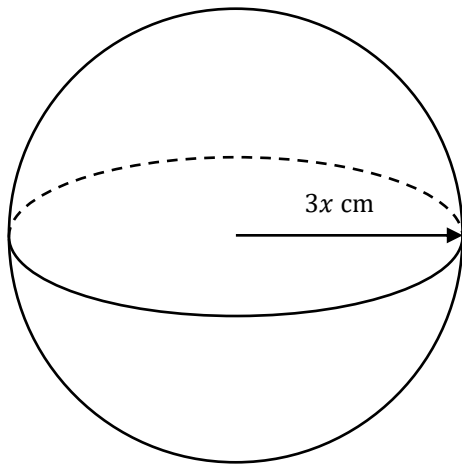

Not drawn accurately

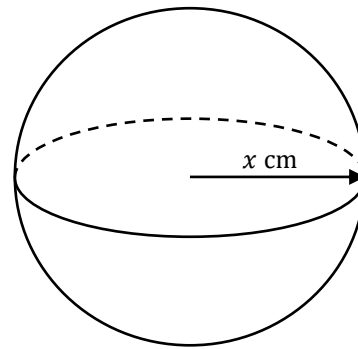

Work out the ratio of the surface area of the two similar spheres shown below.
Give your answer in its simplest form.

[3 marks]

Answer _____

Turn over for next question

- 5 Two mathematically similar ice cream cones are delivered to a shop.
The height of the smaller cone is $\frac{3}{4}$ that of the larger cone, shown below.

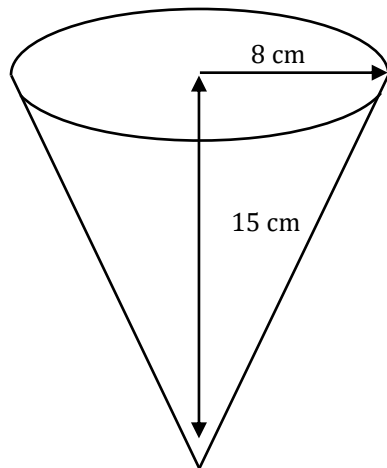

Not drawn accurately

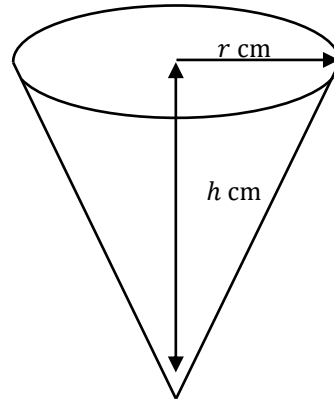

Work out the volume of the smaller cone.

Give your answer in terms of π

[4 marks]

Answer _____

Turn over for next question

6 Two similar cylinders are shown below.

The height of the smaller cylinder is 10 cm and the height of the larger cylinder is 30 cm.

Given the surface area of the smaller cylinder is $30\pi \text{ cm}^2$

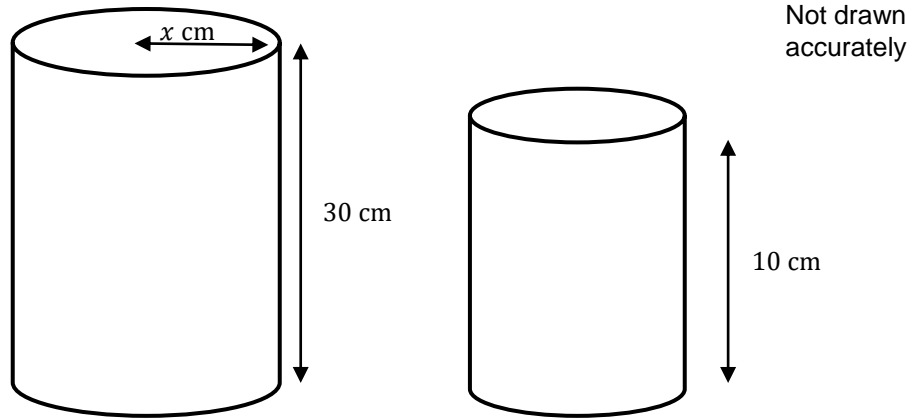

Find the radius of the larger cylinder.

Give your answer to 2 decimal places.

Hint: surface area of a cylinder = $2\pi rh + 2\pi r^2$

[4 marks]

Answer _____

End of Questions