

1 Energy resources can be renewable or non-renewable.

(a) Coal is a non-renewable energy resource.

Name **two** other non-renewable energy resources.

1

2

(2)

(b) Wind turbines are used to generate electricity.

The graph below shows how the power output of a wind turbine changes over one day.

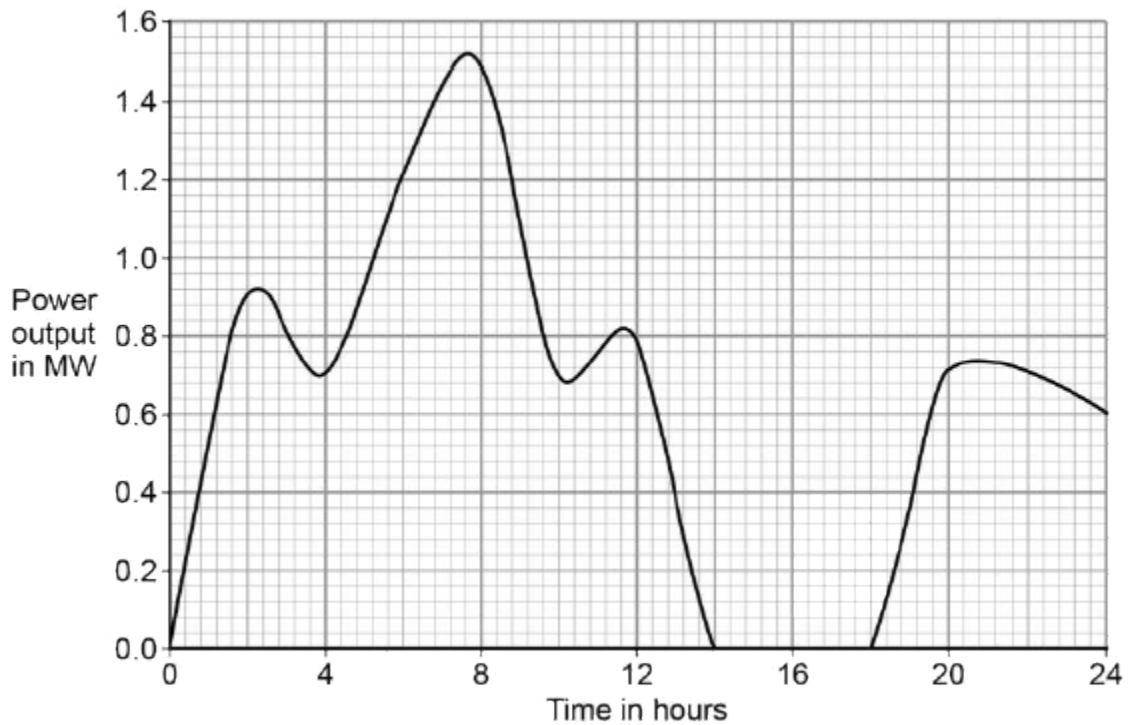

A wind turbine does not generate electricity constantly.

For how many hours did the wind turbine generate no electricity?

.....

Time = hours

(1)

(c) Electrical power is transferred from power stations to the National Grid.

What is the National Grid?

Tick **one** box.

a system of cables and pylons

a system of cables and transformers

a system of cables, transformers and power stations

(1)

(d) An island has a large number of wind turbines and a coal-fired power station.

The island needs to use the electricity generated by the coal-fired power station at certain times.

Choose **one** reason why.

Tick **one** box.

Wind is a renewable energy resource.

Wind turbine power output is constant.

The power output of wind turbines is unpredictable.

The fuel cost for wind turbines is very high.

(1)

(e) A wind turbine has an average power output of 0.60 MW.

A coal-fired power station has a continuous power output of 1500 MW.

Calculate how many wind turbines would be needed to generate the same power output as one coal-fired power station.

.....
.....

Number of wind turbines =

(2)

(f) It is important that scientists develop new energy resources.

Choose **one** reason why.

Tick **one** box.

All energy resources are running out.

All energy resources are used to generate electricity.

Most energy resources have negative environmental effects.

(1)
(Total 8 marks)

2

The National Grid ensures that the supply of electricity always meets the demand of the consumers.

The figure below shows how the output from fossil fuel power stations in the UK varied over a 24-hour period.

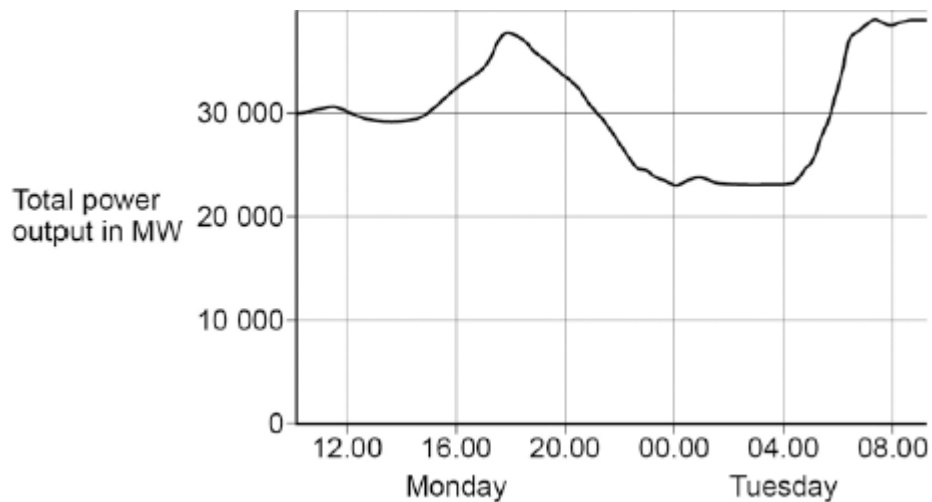

(a) Suggest **one** reason for the shape of the graph between 15.00 and 18.00 on Monday.

.....
.....

(1)

(b) Gas fired power stations reduce their output when demand for electricity is low.

Suggest **one** time on the figure above when the demand for electricity was low.

.....
.....

(1)

- (c) The National Grid ensures that fossil fuel power stations in the UK only produce about 33% of the total electricity they could produce when operating at a maximum output.

Suggest **two** reasons why.

1

.....

2

.....

(2)
(Total 4 marks)

3

Different energy sources are used to generate electricity.

- (a) Use words from the box to match the correct energy source to each of the descriptions given in the table.

biofuel	coal	geothermal	nuclear	waves
----------------	-------------	-------------------	----------------	--------------

Description	Energy source
Energy from the Earth's core is used to heat water.	
Fission of uranium nuclei is used to heat water.	
Gases from rotting plant material are burned to heat water.	

(3)

- (b) Energy can be stored in a pumped storage power station.

The figure shows a pumped storage power station.

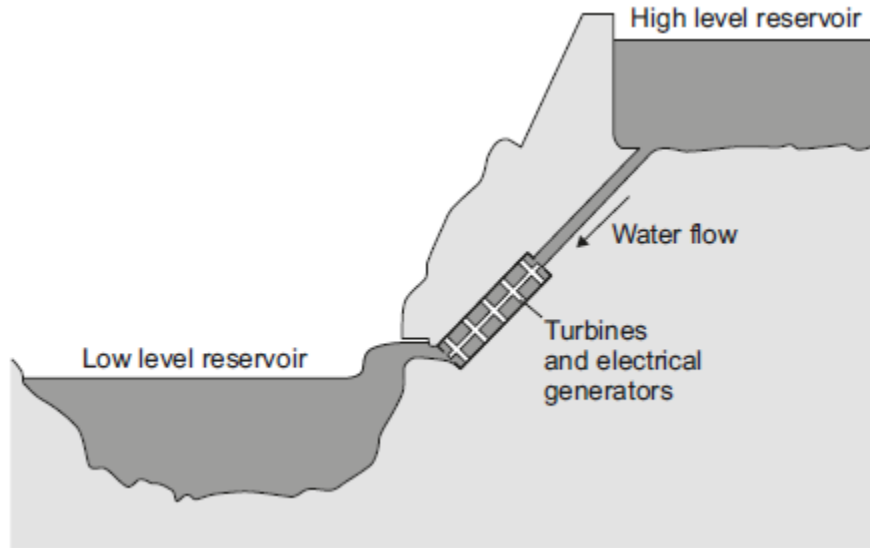

When electricity is needed, the water in the high level reservoir is allowed to flow to the low level reservoir. The flowing water generates electricity.

Use the correct answer from the box to complete each sentence.

electrical	gravitational potential	kinetic	nuclear	sound
-------------------	--------------------------------	----------------	----------------	--------------

The water in the high level reservoir stores energy.

The flowing water has energy.

The water turns the turbine which is connected to the generator.

The generator produces some, this is wasted energy.

(3)

- (c) The total power input to a pumped storage power station is 600 MW.

The useful power output is 540 MW.

- (i) Calculate the efficiency of this pumped storage power station.

.....

Efficiency =

(2)

(ii) Calculate how much power is wasted by the pumped storage power station.

.....

Power = MW

(1)

(iii) How is the temperature of the surroundings affected by the energy wasted by the pumped storage power station?

.....

(1)

(Total 10 marks)

4

A small community of people live in an area in the mountains. The houses are not connected to the National Grid.

The people plan to buy an electricity generating system that uses either the wind or the flowing water in a nearby river.

Figure 1 shows where these people live.

Figure 1



© Brian Lawrence/Getty Images

(a) It would not be economical to connect the houses to the National Grid. Give **one** reason why.

.....
.....
.....
.....

(1)

- (b) In this question you will be assessed on using good English, organising information clearly and using specialist terms where appropriate.

Information about the two electricity generation systems is given in **Figure 2**.

Figure 2

The wind turbine costs £50 000 to buy and install.
The hydroelectric generator costs £20 000 to buy and install.
The average power output from the wind turbine is 10 kW.
The hydroelectric generator will produce a constant power output of 8 kW.

Compare the advantages and disadvantages of the two methods of generating electricity.

Use your knowledge of energy sources as well as information from **Figure 2**.

(6)
(Total 7 marks)

5

All European Union countries are expected to generate 20% of their electricity using renewable energy sources by 2020.

The estimated cost of generating electricity in the year 2020 using different energy sources is shown in **Table 1**.

Table 1

Energy source	Estimated cost (in the year 2020) in pence per kWh
Nuclear	7.8
Solar	25.3
Tidal	18.8
Wind	10.0

France generated 542 billion kWh of electricity using nuclear power stations in 2011.
France used 478 billion kWh of electricity and sold the rest of the electricity to other countries in 2011.

- (a) France may continue generating large amounts of electricity using nuclear power stations instead of using renewable energy resources.

Suggest **two** reasons why.

1.

.....

2.

.....

(2)

- (b) Give **two** disadvantages of generating electricity using nuclear power stations.

1.

.....

2.

.....

(2)

- (c) A panel of solar cells has an efficiency of 0.15.

The total power input to the panel of solar cells is 3.2 kW.

Calculate the useful power output of this panel of solar cells in kW.

.....

.....

.....

.....

Useful power output = kW

(2)

- (d) **Table 2** shows the manufacturing cost and efficiency of different types of panels of solar cells.

Table 2

Type of Solar Panel	Cost to manufacture a 1 m ² solar panel in £	Efficiency in %
A	40.00	20
B	22.50	15
C	5.00	10

Some scientists think that having a low manufacturing cost is more important than improving the efficiency of solar cells.

Use information from **Table 2** to suggest why.

.....

.....

.....

.....

.....

.....

(2)
(Total 8 marks)

6

The image shows a solar thermal power station.

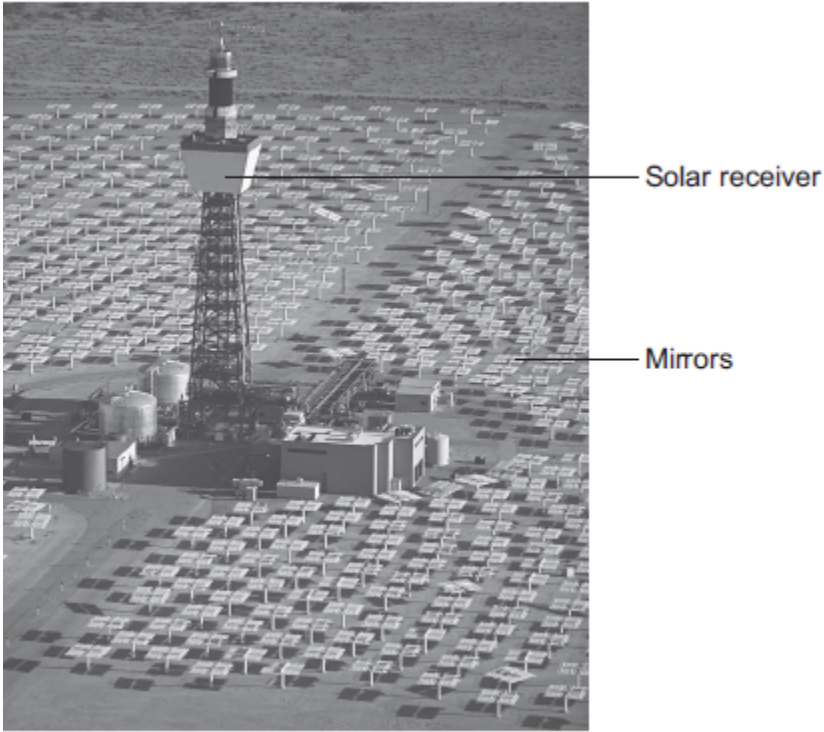

© Kim Steele/Photodisc/Thinkstock

Energy from the Sun is directed at the solar receiver by many mirrors.

(a) (i) Suggest **one** reason why a solar thermal power station is built in a hot desert.

.....
.....

(1)

(ii) Complete the following sentence to describe how the mirrors direct energy from the Sun towards the solar receiver.

Energy from the Sun is by the mirrors
towards the solar receiver.

(1)

- (iii) Heated water is used to generate electricity in the solar thermal power station. Choose the correct answer from the box to complete each sentence.

boiler	motor	transformer	turbine
---------------	--------------	--------------------	----------------

At the solar receiver, water is heated in a
which turns the water into steam. The steam turns a
.....which is connected to a water into steam. The
steam turns a which is connected to a generator.
The generator produces electricity. A is used
to change the voltage for transmission along power lines.

(3)

- (b) A solar storage power station is a new type of solar power station. It is able to store energy from the Sun to generate electricity at night.

The solar storage power station can supply a town with a maximum electrical power of 140 000 kW for 15 hours.

Calculate the maximum energy, in kWh, stored by the solar storage power station.

.....
.....
.....

Energy = kWh

(2)

- (c) A different method of generating electricity uses wind turbines.
A student researching a wind farm wrote the following.

Top Hill Wind Farm has 25 wind turbines.
Last week, one of the wind turbines generated
electricity for only 42 hours out of a possible 168 hours.
My conclusion is that all wind turbines operate for only
25% of the time.

- (i) Give **two** reasons why the student is **not** correct in reaching his conclusion.

1.....

.....

2.....

.....

(2)

- (ii) Give **one** reason why wind turbines do not generate electricity all the time.

.....

.....

(1)

- (iii) Give **one** advantage of using wind turbines to generate electricity compared with
using fossil fuel power stations.

.....

.....

(1)

(Total 11 marks)

7

The image below shows a solar thermal power station that has been built in a hot desert.

The power station uses energy from the Sun to heat water to generate electricity.

Energy from the Sun is reflected towards a solar receiver using many mirrors.

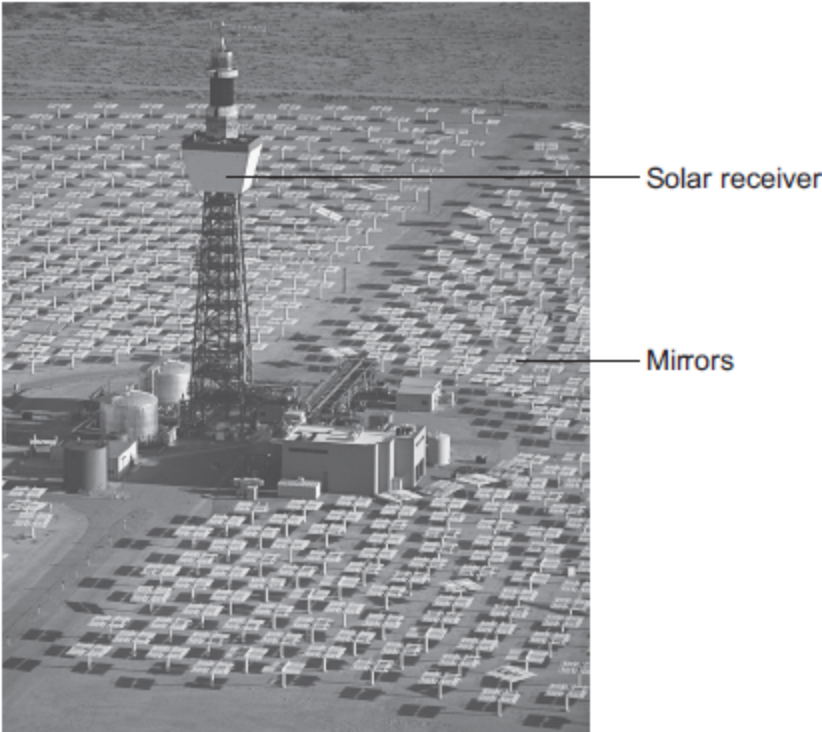

© Kim Steele/Photodisc/Thinkstock

(a) (i) Which part of the electromagnetic spectrum provides most of the energy to heat the water in a solar thermal power station?

.....

(1)

(ii) Describe how heated water is used to generate electricity by this solar thermal power station.
The process is the same as in a fossil fuel power station.

.....
.....
.....
.....
.....
.....

(3)

(b) A new type of solar power station, called a solar storage power station, is able to store energy from the Sun by heating molten chemical salts.

The stored energy can be used to generate electricity at night.

(i) It is important that the molten chemical salts have a high specific heat capacity. Suggest **one** reason why.

.....
.....

(1)

(ii) The solar storage power station can store a maximum of 2 200 000 kWh of energy. The solar storage power station can supply a town with a maximum electrical power of 140 000 kW.

Calculate for how many hours the energy stored by the solar storage power station can supply the town with electrical power.

Give your answer to 2 significant figures.

.....
.....
.....

Time = hours

(3)

(iii) **Table 1** gives information about the place where the solar storage power station has been built.

Table 1

Season	Mean number of daylight hours	Mean power received from the Sun per square metre in kW
Spring	11.5	0.90
Summer	13.5	1.10
Autumn	12.0	0.95
Winter	10.5	0.71

The solar storage power station does not operate at the maximum possible electrical output every day of the year.

Suggest why.

.....

.....

.....

.....

(2)

- (c) Power stations do not work at maximum possible electrical output all the time. The 'capacity factor' of a power station is calculated using the equation:

$$\text{Capacity factor} = \frac{\text{actual electrical output per year}}{\text{maximum possible electrical output per year}}$$

Table 2 shows capacity factors for different types of power station.

Table 2

Type of power station	Renewable energy source	Capacity factor
Coal	No	0.41
Natural gas	No	0.48
Nuclear	No	0.66
Solar thermal	Yes	0.33
Tidal	Yes	0.26
Wind turbine	Yes	0.30

- (i) Compare the capacity factors of the renewable power stations with those of the non-renewable power stations in **Table 2**.

Explain the reason for the difference between the capacity factors.

.....

.....

.....

.....

.....

.....

(3)

- (ii) The capacity factor of a solar storage power station is higher than for all other renewable power stations.

Suggest **one** reason why.

.....

.....

(1)

(Total 14 marks)

8

Iceland is a country that generates most of its electricity using geothermal power stations and hydroelectric power stations.

- (a) (i) Complete the following sentences to describe how some geothermal power stations work.

In regions where volcanoes are active, the ground is hot.

Cold is pumped down into the ground

and is by hot rocks.

It returns to the surface as steam. The steam is used to turn a turbine.

The turbine drives a to produce electricity.

(3)

(ii) Which **one** of the following statements about geothermal power stations is true?

Tick (✓) **one** box.

Geothermal power stations use fossil fuels.

Geothermal power stations produce carbon dioxide.

Geothermal power stations provide a reliable source of electricity.

(1)

(b) What is needed for a hydroelectric power station to be able to generate electricity?

Tick (✓) **one** box.

Falling water

A long coastline

Lots of sunny days

(1)

(Total 5 marks)

9

Electricity can be generated using various energy sources.

(a) Give **one** advantage and **one** disadvantage of using nuclear power stations rather than gas-fired power stations to generate electricity.

Advantage

.....

Disadvantage

.....

(2)

(b) (i) A single wind turbine has a maximum power output of 2 000 000 W.

The wind turbine operated continuously at maximum power for 6 hours.

Calculate the energy output in kilowatt-hours of the wind turbine.

.....
.....
.....

Energy output = kWh

(2)

(ii) Why, on average, do wind turbines operate at maximum power output for only 30% of the time?

.....
.....

(1)

(c) An on-shore wind farm is made up of many individual wind turbines.

They are connected to the National Grid using underground power cables.

Give **one** advantage of using underground power cables rather than overhead power cables.

.....
.....

(1)

(Total 6 marks)

10

(a) Iceland is a country that generates nearly all of its electricity from renewable sources.

In 2013, about 80% of Iceland's electricity was generated using hydroelectric power stations (HEP).

Describe how electricity is generated in a hydroelectric power station. Include the useful energy transfers taking place.

.....

.....

.....

.....

.....

.....

.....

.....

.....

.....

.....

.....

.....

.....

.....

.....

.....

.....

.....

.....

.....

.....

(4)

(b) The UK produces most of its electricity from fossil fuels.

Many people in the UK leave their televisions in 'stand by' mode when not in use, instead of switching them off.

It is better for the environment if people switch off their televisions, instead of leaving them in 'stand by' mode.

Explain why.

.....

.....

.....

.....

.....

.....

.....

.....

.....

.....

(3)

(c) A scientist wrote in a newspaper:

'Appliances that do not automatically switch off when they are not being used should be banned.'

Suggest why scientists alone cannot make the decision to ban these appliances.

.....
.....

(1)
(Total 8 marks)

11

Solar panels are often seen on the roofs of houses.

(a) Describe the action and purpose of a solar panel.

.....
.....
.....
.....

(2)

(b) Photovoltaic cells transfer light energy to electrical energy.

In the UK, some householders have fitted modules containing photovoltaic cells on the roofs of their houses.

Four modules are shown in the diagram.

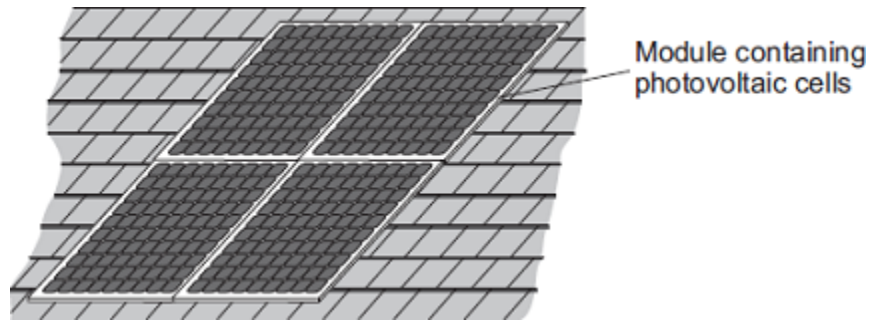

The electricity company pays the householder for the energy transferred.

The maximum power available from the photovoltaic cells shown in the diagram is $1.4 \times 10^3 \text{ W}$.

How long, in minutes, does it take to transfer 168 kJ of energy?

.....
.....
.....
.....
.....
.....
..... Time = minutes

(3)

- (c) When the modules are fitted on a roof, the householder gets an extra electricity meter to measure the amount of energy transferred by the photovoltaic cells.
- (i) The diagram shows two readings of this electricity meter taken three months apart. The readings are in kilowatt-hours (kWh).

21 November	0	0	0	4	4
21 February	0	0	1	9	4

Calculate the energy transferred by the photovoltaic cells during this time period.

.....

Energy transferred = kWh

(1)

- (ii) The electricity company pays 40p for each kWh of energy transferred.
Calculate the money the electricity company would pay the householder.

.....

.....

Money paid =

(2)

- (iii) The cost of the four modules is £6000.
Calculate the payback time in years for the modules.

.....

.....

Payback time = years

(3)

- (iv) State an assumption you have made in your calculation in part **(iii)**.

.....

.....

(1)

(d) In the northern hemisphere, the modules should always face south for the maximum transfer of energy.

State **one** other factor that would affect the amount of energy transferred during daylight hours.

.....
.....

(1)
(Total 13 marks)

12

(a) The pie chart shows the proportions of electricity generated in the UK from different energy sources in 2010.

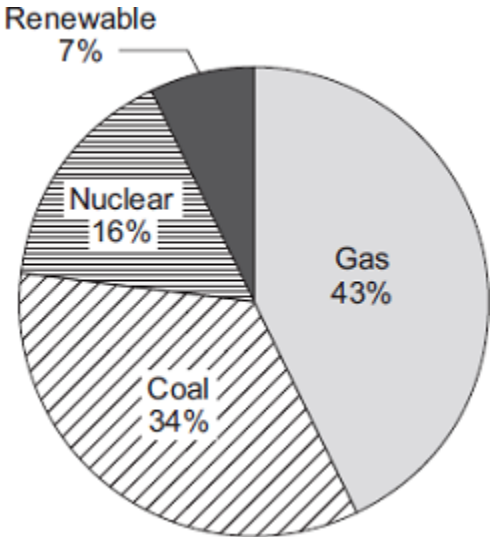

(i) Calculate the percentage of electricity generated using fossil fuels.

.....

Percentage = %

(1)

- (ii) The pie chart shows that 7% of electricity was generated using renewable energy sources.

Which **one** of the following is **not** a renewable energy source?

Tick (✓) **one** box.

Oil

Solar

Wind

(1)

- (b) Complete the following sentence.

In some types of power station, fossil fuels are burned to heat to produce steam.

(1)

- (c) Burning fossil fuels releases carbon dioxide into the atmosphere.

Why do many scientists think adding carbon dioxide to the atmosphere is harmful to the environment?

Tick (✓) **one** box.

Carbon dioxide is the main cause of acid rain.

Carbon dioxide causes global warming.

Carbon dioxide causes visual pollution.

(1)

(Total 4 marks)

13

(a) A student investigated how the number of blades on a wind turbine affects the output voltage of the turbine.

The student used the apparatus shown in the diagram.

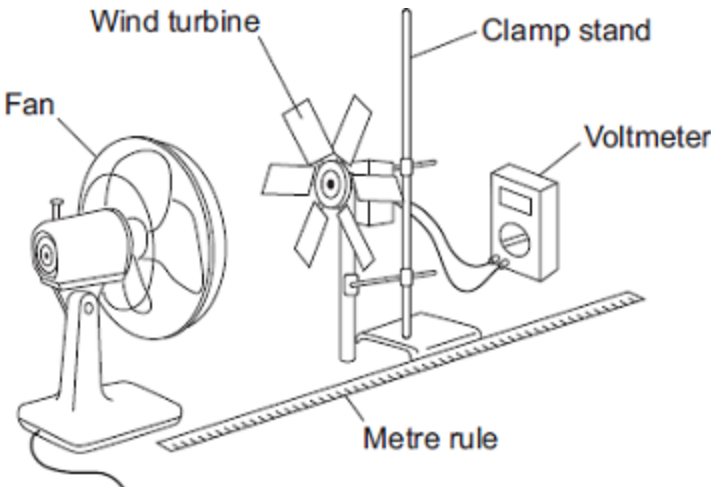

The fan was used to turn the wind turbine.

(i) The fan was always the same distance from the wind turbine.

Why?

.....
.....

(1)

(ii) After switching the fan on, the student waited 20 seconds before taking the voltmeter reading.

Suggest why.

.....
.....

(1)

(iii) The student changed the number of blades on the wind turbine.

The student's results are shown in the scatter graph.

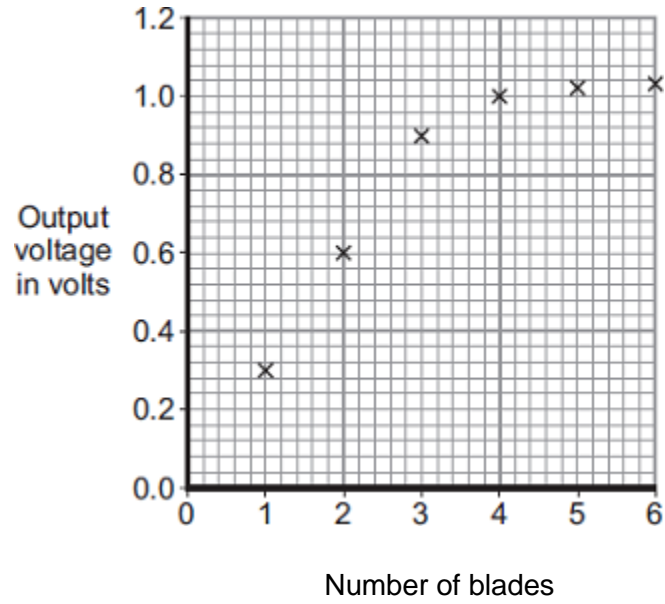

What conclusion can be made from the results in the scatter graph?

.....

.....

.....

.....

(2)

(b) The amount of electricity generated using wind turbines is increasing.

Which graph, **A**, **B** or **C**, is most likely to show the electrical power output from a wind turbine over one day?

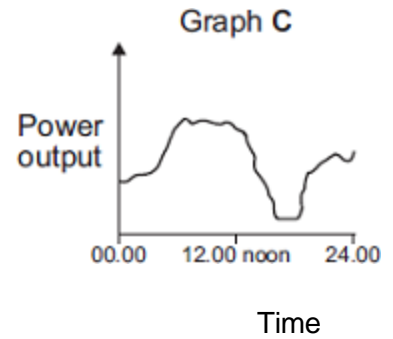
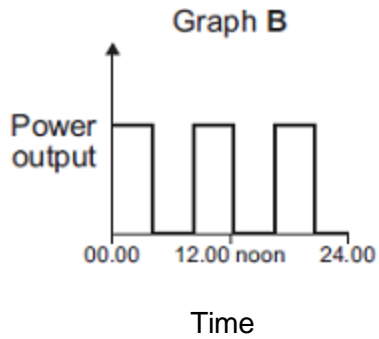
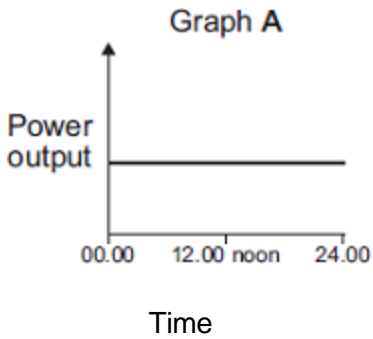

Write the correct answer, **A**, **B** or **C**, in the box.

Give a reason for your answer.

.....
.....
.....

(2)
(Total 6 marks)

14

(a) In the UK, over 70% of the electricity is generated in power stations that burn fossil fuels.

(i) Explain **one** effect that burning fossil fuels has on the environment.

.....
.....
.....
.....

(2)

(ii) Give **one** way the effect on the environment described in part (a)(i) could be reduced.

Assume the amount of fossil fuels burnt stays the same.

.....
.....

(1)

(b) Electricity can also be generated in a pumped storage hydroelectric power station.

An advantage of pumped storage hydroelectric power stations is the short start-up time they have.

(i) What is the importance of the short start-up time?

.....
.....

(1)

(ii) Give **one** other advantage of a pumped storage hydroelectric power station.

.....
.....

(1)

(c) Read the extract below from a newspaper article.

In the future it may not be possible to have constant electricity. Families will have to get used to using power when it is available.

(i) In the UK, the proportion of electricity generated using wind turbines is due to increase a lot. Some opponents of wind turbines think this increase will cause big fluctuations in the electricity supply.

Suggest **one** reason why this may be true.

.....
.....

(1)

(ii) Between 2002 and 2008 the amount of electricity used for lighting in homes in the UK decreased.

Suggest **one** reason why.

.....
.....

(1)

(Total 7 marks)

15

Three energy sources used to generate electricity are given in **List A**.
Statements about the energy sources used to generate electricity are given in **List B**.

Draw **one** line from each energy source in **List A** to the statement about the energy source in **List B**.

List A Energy source	List B Statement about energy source
Geothermal	Uses energy from falling water
Hydroelectric	Uses energy from inside the Earth
Nuclear	Is unpredictable
	Produces dangerous waste

(Total 3 marks)

16

The picture shows a temporary road traffic information board.

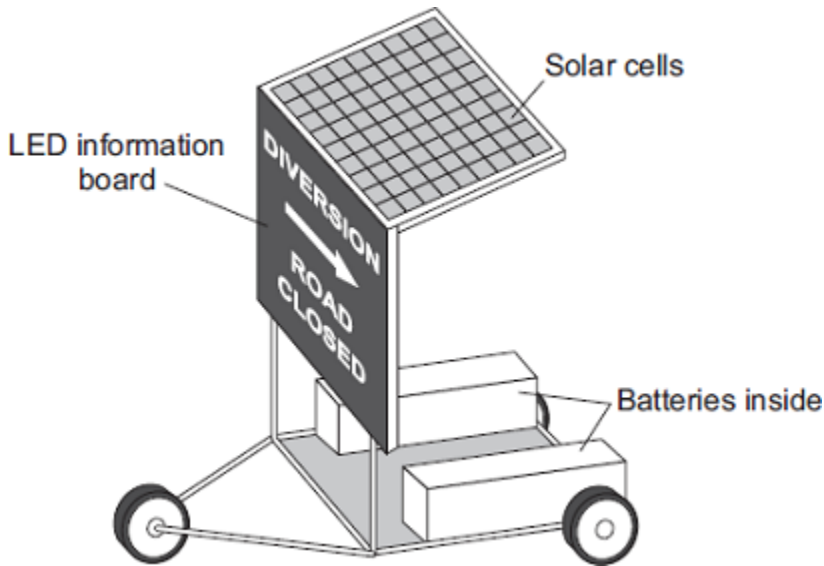

The batteries power the LEDs used in the information board.
The solar cells keep the batteries charged.

(a) Use words from the box to complete each of the following sentences.

chemical	electrical	light	sound
-----------------	-------------------	--------------	--------------

The solar cells transfer light energy to energy.

The batteries transfer energy to electrical energy.

The LEDs transfer electrical energy to energy.

(3)

(b) When the total energy input to the solar cells is 200 joules, the useful energy output from the solar cells to the batteries is 50 joules.

Calculate the efficiency of the solar cells.

.....

.....

.....

Efficiency =

(2)

(c) Which **one** of the following statements gives the reason for using solar cells to charge the batteries?

Tick (✓) **one** box.

Solar cells will charge the batteries day and night.

The information board can be used anywhere it is needed.

A small number of solar cells produce a lot of electricity.

(1)
(Total 6 marks)

17

(a) The graph shows how the demand for electricity in the UK changes during one 24-hour period.

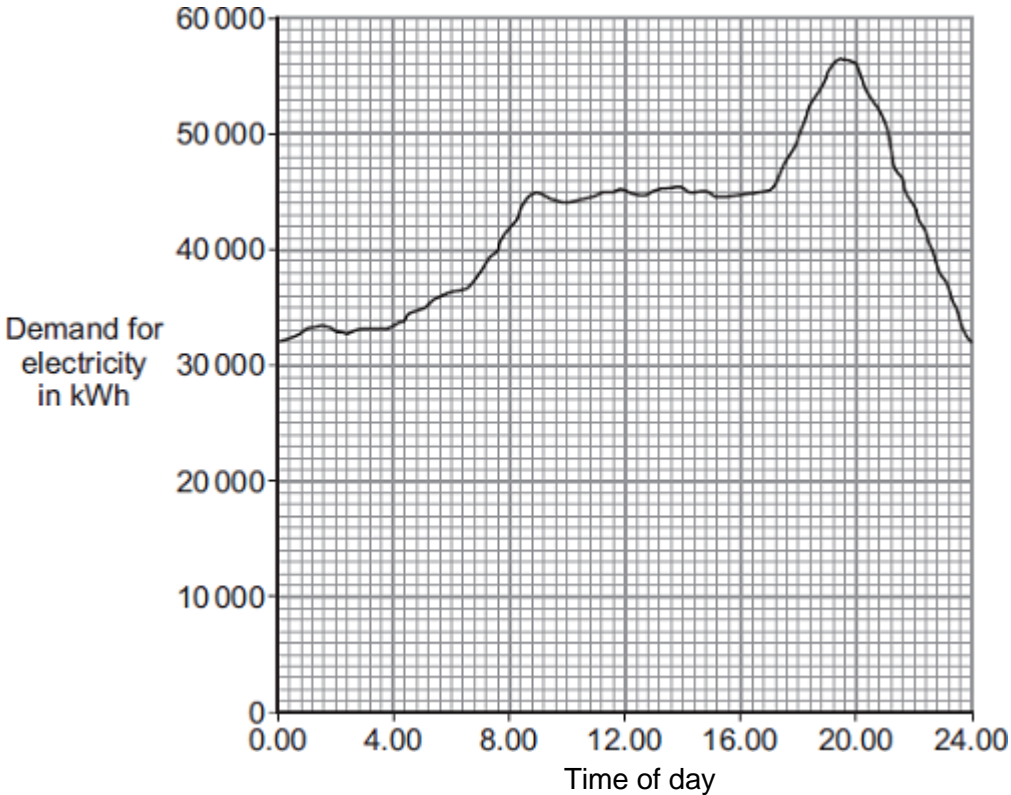

The table gives the start-up times for two types of power station.

Type of power station	Start-up time
Gas	A few minutes
Nuclear	Several days

How would these two types of power station be used to meet the demand for electricity during this 24-hour period?

.....

.....

.....

.....

.....

.....

(3)

- (b) *In this question you will be assessed on using good English, organising information clearly and using specialist terms where appropriate.*

A farmer plans to generate all the electricity needed on her farm, using either a biogas generator or a small wind turbine.

The biogas generator would burn methane gas. The methane gas would come from rotting the animal waste produced on the farm. When burnt, methane produces carbon dioxide.

The biogas generator would cost £18 000 to buy and install. The wind turbine would cost £25 000 to buy and install.

The average power output from the wind turbine would be the same as the continuous output from the biogas generator.

Evaluate the advantages and disadvantages of the two methods of generating electricity.

Conclude, with a reason, which system would be better for the farmer to buy and install.

.....

.....

.....

.....

.....

.....

.....

.....

.....

.....

(6)
(Total 9 marks)

18

About half of the UK's electricity is generated in coal-burning power stations and nuclear power stations.

- (a) Coal-burning power stations and nuclear power stations provide a reliable way of generating electricity.

What is meant by a *reliable way of generating electricity*?

.....

.....

(1)

(b) Over the next few years, most of the older nuclear power stations in the UK will be closed down, and the process of decommissioning will start.

What does it mean to *decommission* a nuclear power station?

.....
.....

(1)

(c) Climate change has been strongly linked to the emission of carbon dioxide. Many governments around the world are committed to reducing carbon dioxide emissions.

Generating electricity can increase carbon dioxide emissions.

The companies generating electricity could reduce carbon dioxide emissions.

Give **two** ways the companies could do this.

1
.....

2
.....

(2)

(d) Electricity is distributed from power stations to consumers along the National Grid.

The voltage across the overhead cables of the National Grid needs to be much higher than the output voltage from the power station generators.

Explain why.

.....
.....
.....
.....
.....
.....

(3)

(Total 7 marks)

19

Wind and tides are energy sources that are used to generate electricity.

(a) Complete each sentence by putting a tick (✓) in the box next to the correct answer.

(i) The wind is

a non-renewable energy source.

a constant energy source.

an unreliable energy source.

(1)

(ii) The tides are

a renewable energy source.

a constant energy source.

an unreliable energy source.

(1)

(b) If wood is to be used as a renewable energy source, what must be done each time a tree is chopped down?

.....

.....

(1)

- (c) In the UK, electricity is generated using renewable and non-renewable energy sources. The graph shows the percentage of electricity generated using renewable energy sources between 1990 and 2005.

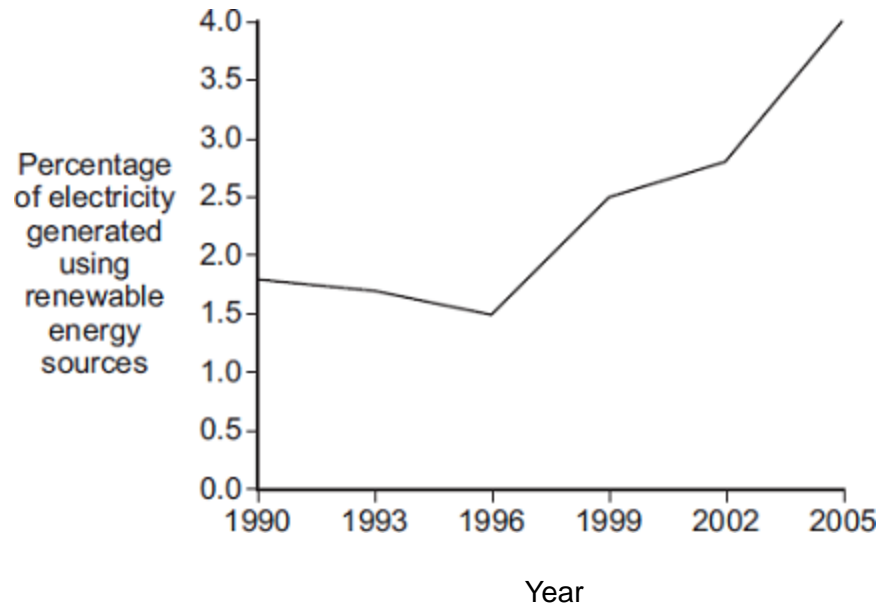

Complete the following sentence by drawing a ring around the correct answer in the box.

In 2015, the percentage of electricity generated using renewable energy sources

is most likely to be

- | |
|-------------------|
| greater than 4 %. |
| equal to 4 %. |
| less than 4 %. |

(1)
(Total 4 marks)

20

The picture shows a solar-powered aircraft. The aircraft has no pilot.



By NASA/Nick Galante [Public domain], via Wikimedia Commons

(a) Use words from the box to complete the following sentence.

electrical	heat	light	sound
-------------------	-------------	--------------	--------------

Solar cells are designed to transform energy
 into energy.

(2)

(b) On a summer day, 175 000 joules of energy are supplied to the aircraft’s solar cells every second. The useful energy transferred by the solar cells is 35 000 joules every second.

Use the equation in the box to calculate the efficiency of the solar cells.

$\text{efficiency} = \frac{\text{useful energy transferred by the device}}{\text{total energy supplied to the device}}$

Show clearly how you work out your answer.

.....

Efficiency =

(2)

(c) The aircraft propellers are driven by electric motors.

Give **one** environmental advantage of using electric motors to drive the aircraft propellers rather than motors that burn a fuel.

.....
.....

(1)
(Total 5 marks)

21

(a) Solar energy is a *renewable* energy source used to generate electricity.

(i) What is meant by an energy source being *renewable*?

.....
.....

(1)

(ii) Name **two** other renewable energy sources used to generate electricity.

1

2

(1)

- (b) A householder uses panels of solar cells to generate electricity for his home. The solar cells are tilted to receive the maximum energy input from the Sun.

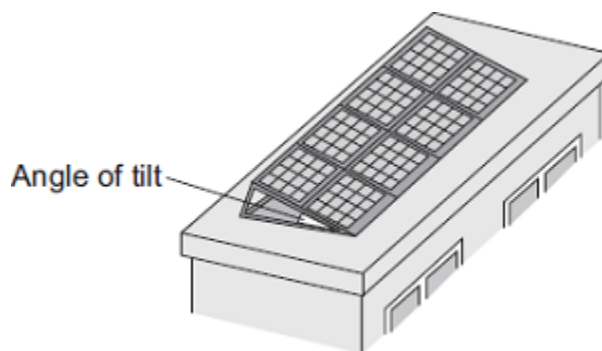

The data in the table gives the average energy input each second (in J/s), to a 1 m² area of solar cells for different angles of tilt and different months of the year.

Month	Angle of tilt			
	20°	30°	40°	50°
February	460	500	480	440
April	600	620	610	600
June	710	720	680	640
August	640	660	640	580
October	480	520	500	460
December	400	440	420	410

- (i) Use the data in the table to describe how the average energy input to the solar cells depends on the angle of tilt.

.....

.....

.....

.....

(2)

- (ii) The total area of the solar cell panels used by the householder is 5 m².

The efficiency of the solar cells is 0.18.

Calculate the average **maximum** electrical energy available from the solar cell panels each second in June.

Show clearly how you work out your answer.

.....

Maximum energy = joules/second

(3)

- (c) The diagram shows part of the National Grid.

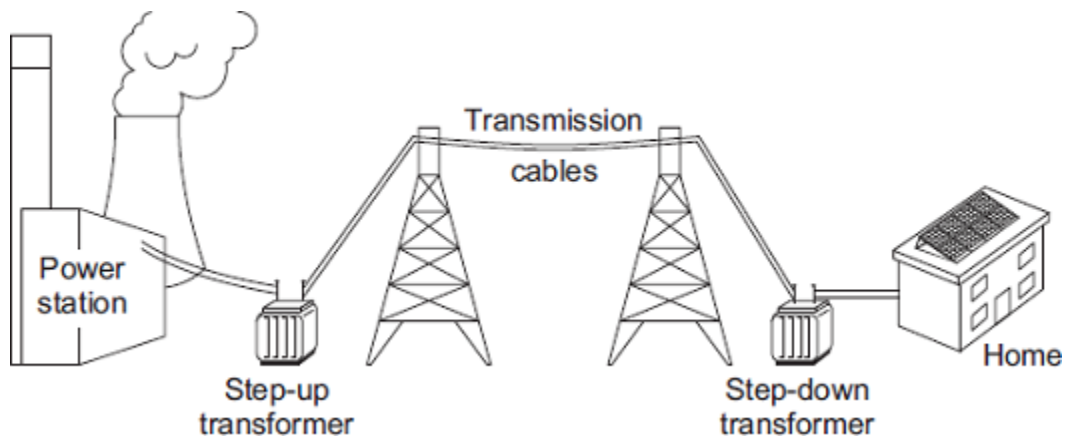

- (i) Even though the householder uses solar cells to generate electricity for his home, the home stays connected to the National Grid.

Give **one** reason why the householder should stay connected to the National Grid.

.....

(1)

- (ii) The step-up transformer increases the efficiency of the National Grid.

Explain how.

.....

(2)

(Total 10 marks)

22

Electricity is generated in power stations. It is then sent to all parts of the country through a network of cables.

(a) Complete the following sentence by using **one** of the words in the box.

Grid	Power	Supply
-------------	--------------	---------------

The network is called the National

(1)

(b) In the diagram, **A, B, C** and **D** are transformers.

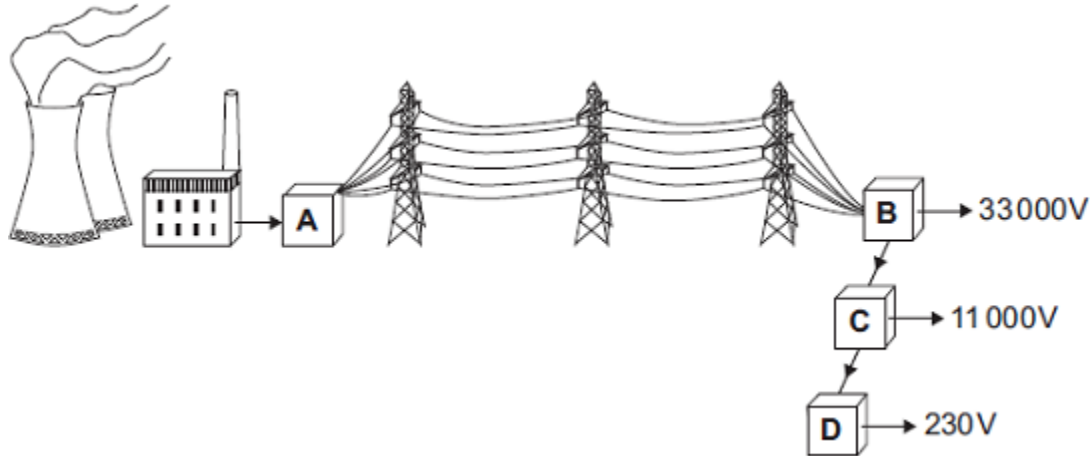

(i) Which transformer, **A, B, C** or **D**, is a step-up transformer?

Transformer

(1)

(ii) Which transformer, **A, B, C** or **D** will supply homes, offices and shops?

Transformer

(1)

(c) Complete the following sentence by drawing a ring around the correct line in the box.

In a step-up transformer, the potential difference (p.d.) across the

primary coil is

less than
the same as
more than

the p.d. across the secondary coil.

(1)

(Total 4 marks)

23

A student has read that a solar cell with a dirty surface will not work as well as a solar cell with a clean surface.

To test the effect of a dirty surface on a solar cell, the student set up the following equipment.

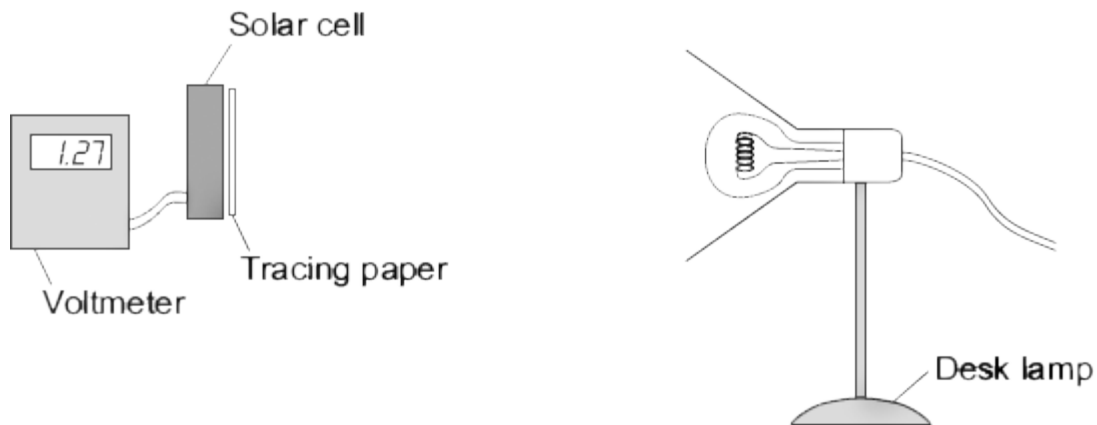

The student put the desk lamp a fixed distance from the solar cell. To represent the effect of a dirty surface, the student covered the surface of the solar cell with pieces of tracing paper. Each time the student added a piece of paper, she measured the output voltage of the solar cell.

(a) The results taken by the student have been used to draw the graph below.

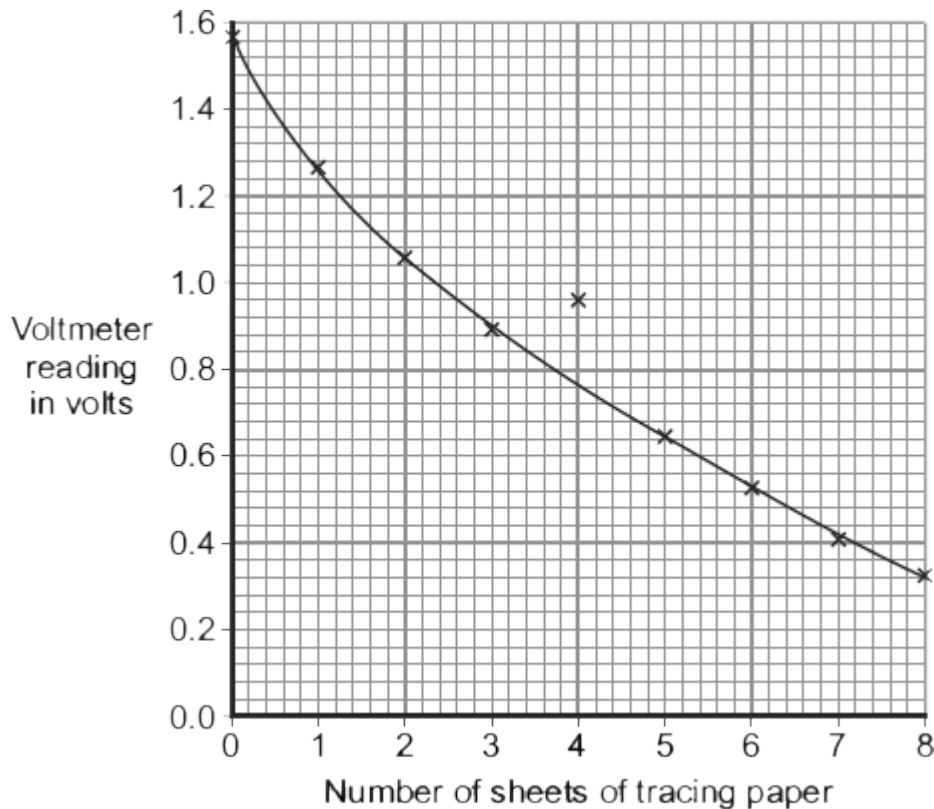

(i) One of the results seems to be anomalous.

Draw a ring around the anomalous data point on the graph.

(1)

- (ii) The larger the number of sheets of tracing paper used, the lower the intensity of the light reaching the solar cell.

Draw a ring around the correct answer in the box to complete the sentence.

A decrease in the intensity of the light reaching the solar cell causes

a decrease in
no change to
an increase in

(1)

the output voltage from the solar cell.

- (b) People can buy panels of solar cells to generate electricity for their homes. Any surplus electricity can be sold to the electricity supply company.

- (i) Give **one** environmental advantage of generating electricity using solar cells rather than generating electricity in a coal-burning power station.

.....
.....

(1)

- (ii) A homeowner pays £7600 to have solar panels fitted on the roof of their house. The homeowner expects to save £950 each year from reduced energy bills and from selling the electricity.

Assuming these figures to be correct, calculate the pay-back time for the solar panels.

Show clearly how you work out your answer.

.....
.....
.....

Pay-back time = years

(2)

(iii) Draw a ring around the correct answer in the box to complete the sentence.

Allowing the surface of the solar panels to become very dirty will

- | |
|------------|
| decrease |
| not change |
| increase |

the pay-back time.

(1)

(iv) Explain your answer to part (b)(iii).

.....

.....

.....

.....

(2)

(Total 8 marks)

24

The diagram shows the National Grid system.

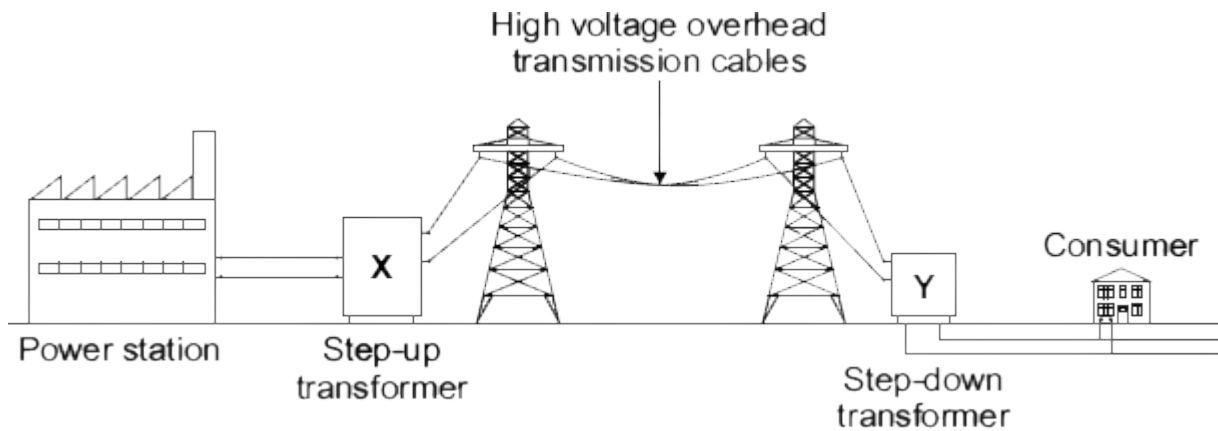

(a) The National Grid includes step-up transformers.

Explain why.

.....

.....

.....

.....

(2)

- (b) *In this question you will be assessed on using good English, organising information clearly and using specialist terms where appropriate.*

Over the next 10 years, more than 300 kilometres of new high voltage transmission cables are to be added to the National Grid. Most of the new cables will be suspended from pylons and run overhead while the rest will be buried underground.

Outline the advantages and disadvantages of both overhead transmission cables and underground transmission cables.

.....

.....

.....

.....

.....

.....

.....

.....

.....

.....

.....

.....

.....

.....

.....

.....

(6)

(c) When an electric current flows through a transmission cable, a magnetic field is produced.

The graph shows how the strength of the magnetic field varies with distance from both overhead and underground transmission cables that carry the same current.

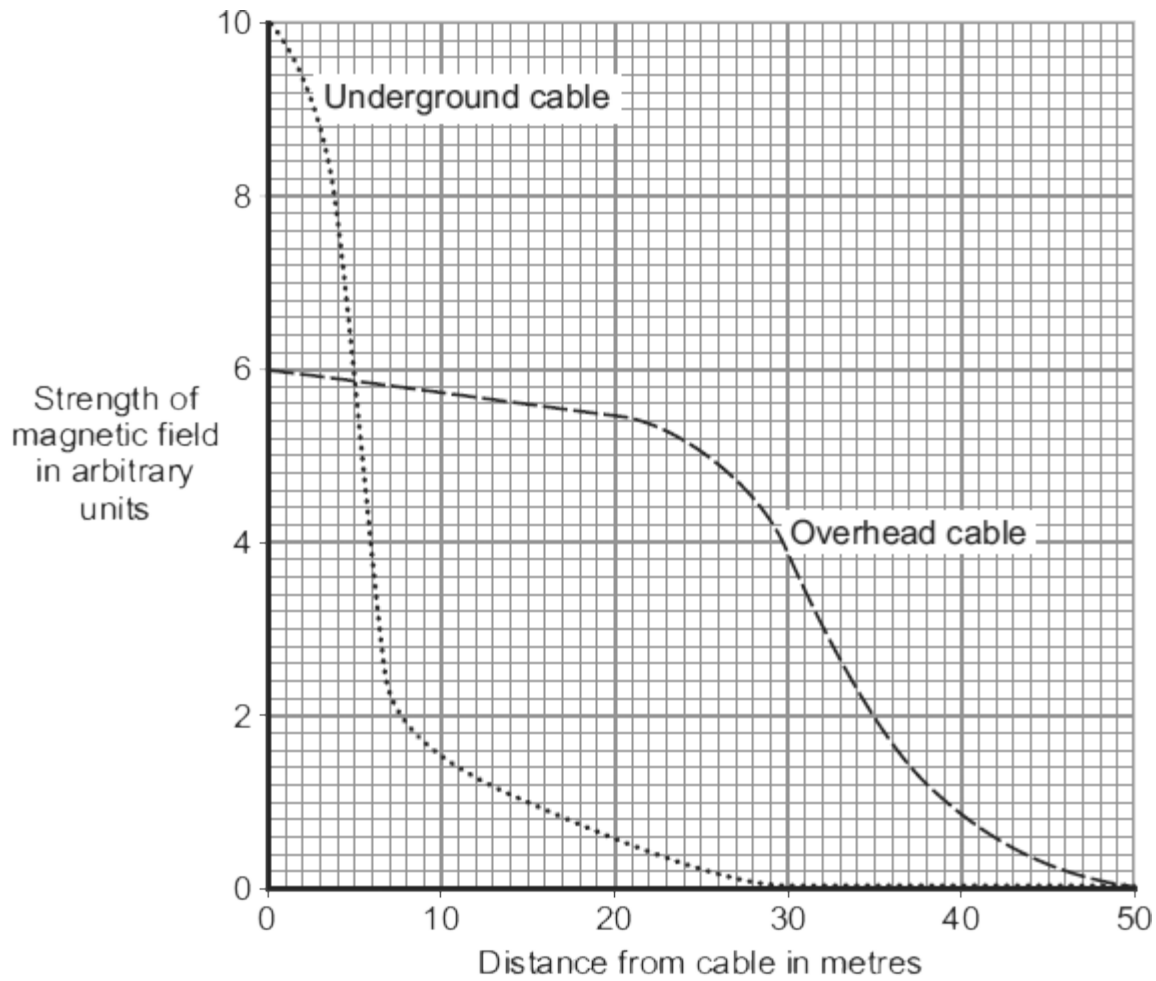

What conclusions may be drawn from this graph?

.....

.....

.....

.....

(2)

- (d) Some people think that, because of the magnetic fields, living close to transmission cables is dangerous to health. Laboratory studies on mice and rats exposed to magnetic fields for two or more years found that the magnetic fields had no effect on the animals' health.

Draw a ring around the correct answer in the box to complete the sentence.

Using animals in scientific research raises

economic
environmental
ethical

 issues.

(1)
(Total 11 marks)

25

- (a) Nuclear fuels and the wind are two of the energy sources used to generate electricity in the UK.

Explain the advantages of using energy from nuclear fuels to generate electricity rather than using energy from the wind.

Include in your answer a brief description of the process used to generate electricity from nuclear fuels.

.....

.....

.....

.....

.....

.....

.....

.....

.....

(4)

- (b) In the UK, most electricity is generated in power stations that emit carbon dioxide into the atmosphere. The impact of these power stations on the environment could be reduced by the increased use of 'carbon capture' technology.

Describe how 'carbon capture' would prevent the build-up of carbon dioxide in the atmosphere.

.....
.....
.....
.....
.....

(2)
(Total 6 marks)

26

The world's biggest offshore wind farm, built off the Kent coast, started generating electricity in September 2010.

- (a) One advantage of using the wind to generate electricity is that it is a renewable energy source.

- (i) Give **one** other advantage of using the wind to generate electricity.

.....
.....

(1)

- (ii) Name **one** other renewable energy source used to generate electricity.

.....

(1)

(b) The graph shows how wind speed affects the power output from a large wind turbine.

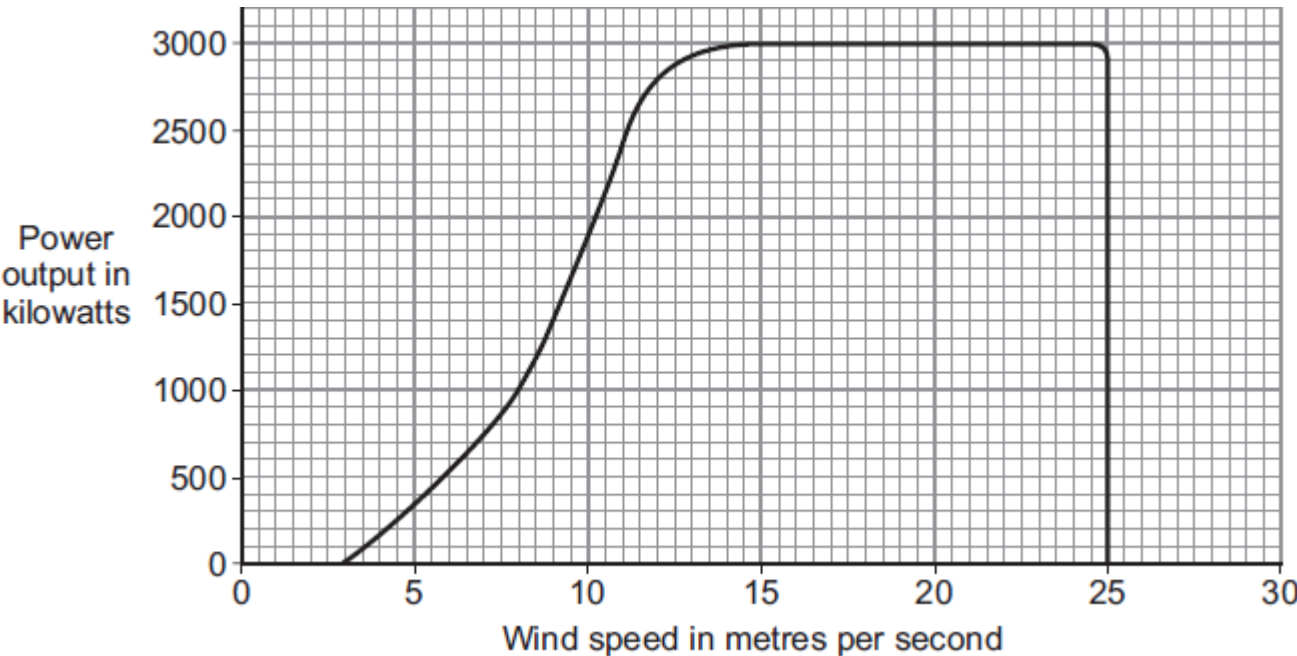

(i) What is the maximum possible power output from this wind turbine?

.....

(1)

(ii) Read this part of a newspaper article.

Cold weather stops wind turbines
For the past two weeks, most of the UK's wind turbines have been generating less than one sixth of their maximum power output. To avoid major power cuts in the future, some experts have said that more nuclear power stations need to be built to provide a reliable source of energy.

Use the graph to explain why the power output from the wind turbines was less than one sixth of the maximum.

.....
.....
.....
.....

(2)

(iii) Having more nuclear power stations will help to avoid power cuts in the future.

Which **two** of these reasons explain why?

Put a tick (✓) in the boxes next to your answers.

A small amount of nuclear fuel generates a large amount of electricity.

The radioactive waste produced must be stored for many years.

Nuclear power stations do not depend on the weather to generate electricity.

(1)
(Total 6 marks)

27

The world's biggest offshore wind farm, built off the Kent coast, started generating electricity in September 2010.

(a) The graph shows how wind speed affects the power output from one of the wind turbines.

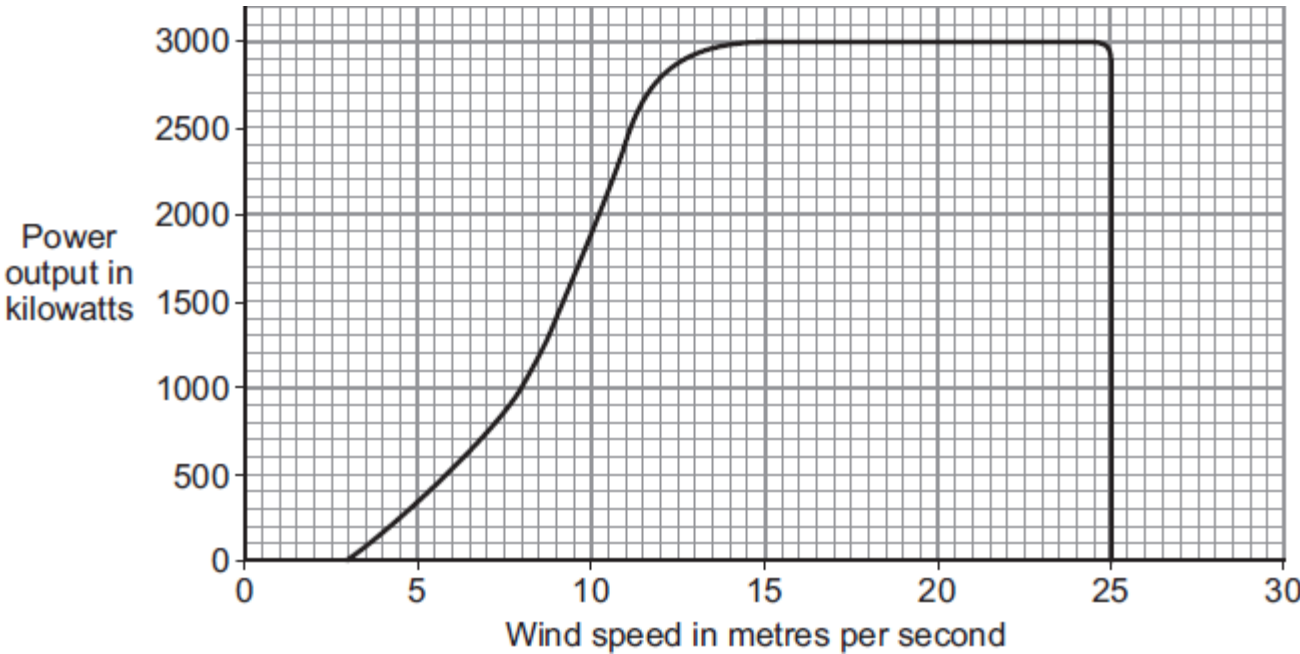

In one 4-hour period, the wind turbine transfers 5600 kilowatt-hours of electrical energy.

Use the data in the graph to calculate the average wind speed during this 4-hour period.

Show clearly how you work out your answer.

.....

.....

.....

.....

Average wind speed = m/s

(3)

(b) The wind turbines are linked to the National Grid by underwater cables.

(i) What is the National Grid?

.....

.....

(1)

(ii) How is the National Grid designed to reduce energy losses during transmission?

.....
.....
.....

(1)

(c) Read this extract from a newspaper.

Power crisis as island basks in sunshine
The population of a small island off the coast of Scotland decided to generate all their electricity from water and wind. However, they did not predict having a long period of warm, dry weather. A combination of low water levels and hardly any wind has drastically reduced the output from the hydroelectric power station and wind turbines.

Explain **one** way in which the islanders could try to ensure that a similar power crisis does **not** happen in the future.

.....
.....
.....
.....

(2)
(Total 7 marks)

28

In the UK, most electricity is generated in power stations that burn fossil fuels.

(a) Which type of fossil fuel power station has the shortest start-up time?

.....

(1)

(b) The diagram shows how electricity is distributed around the UK.

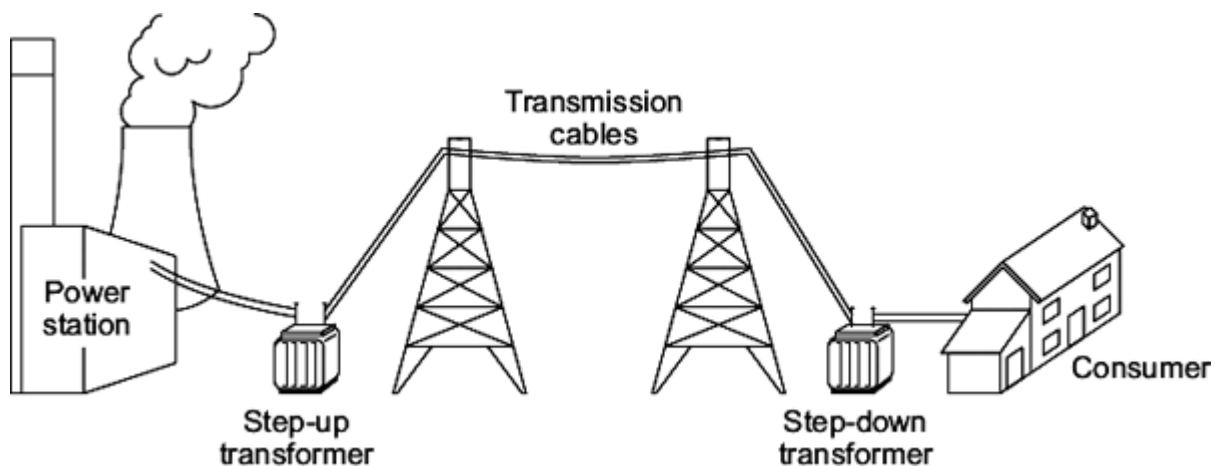

(i) Which of the parts labelled in the diagram form the National Grid?

.....

(1)

(ii) A step-up transformer is used near the power station.

Draw a ring around the correct answer in each box to complete each sentence.

A step-up transformer increases the

- current.
- power.
- voltage.

Using a step-up transformer makes the distribution of electricity

- less dangerous.
- more efficient.
- work faster.

(2)

(c) Electricity in the UK is also generated without using fossil fuels.

The graph shows how the percentage of electricity generated in the UK without using fossil fuels changed between 1990 and 2010.

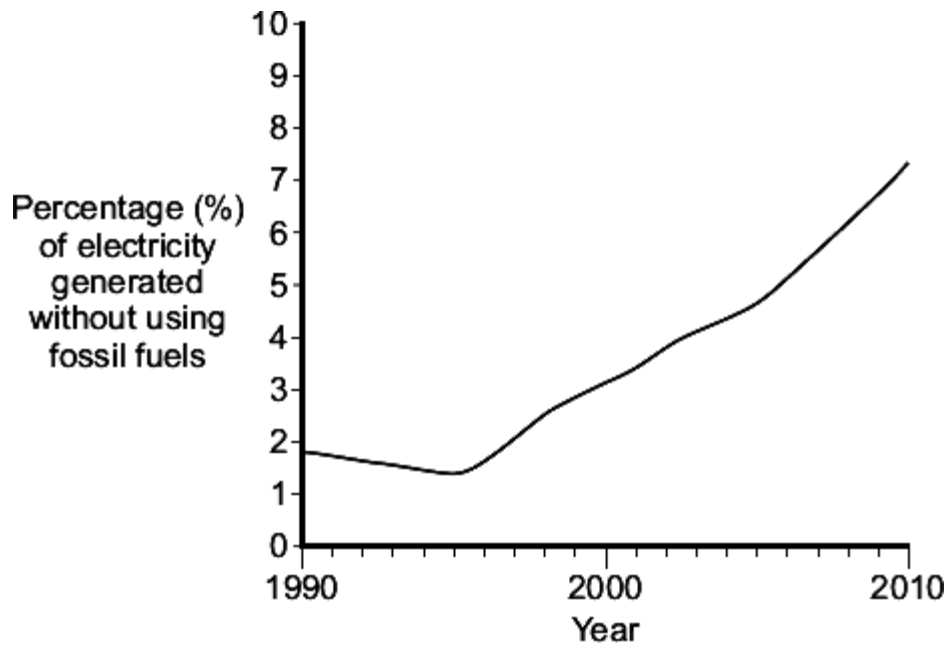

What does the data in the graph suggest will probably happen to the percentage of electricity generated in the UK without using fossil fuels over the next 10 years?

.....

.....

(1)
(Total 5 marks)

29

(a) Geothermal energy and the energy of falling water are two resources used to generate electricity.

(i) What is geothermal energy?

.....

.....

(1)

(ii) Hydroelectric systems generate electricity using the energy of falling water.

A pumped storage hydroelectric system can also be used as a way of storing energy for future use.

Explain how.

.....

.....

.....

.....

.....

.....

(2)

(b) *In this question you will be assessed on using good English, organising information clearly and using specialist terms where appropriate.*

Read the following extract from a newspaper.

Britain may be switched on by Iceland

Iceland is the only country in the world generating all of its electricity from a combination of geothermal and hydroelectric power stations. However, Iceland is using only a small fraction of its energy resources. It is estimated that using only these resources, the amount of electricity generated could be increased by up to four times.

To help supply the future demand for electricity in Britain, there are plans to build thousands of new offshore wind turbines. It has also been suggested that the National Grid in Britain could be linked to the electricity generating systems in Iceland. This would involve laying a 700 mile undersea electricity cable between Iceland and Britain.

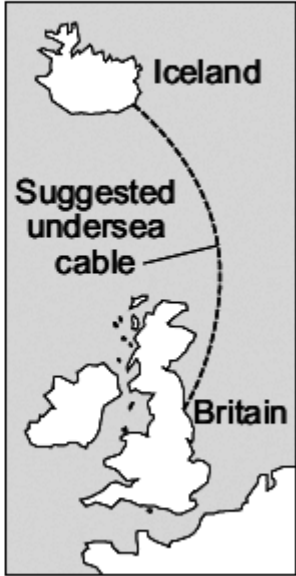

The diagram is a map showing the geographical relationship between Iceland and Britain. Iceland is located to the northwest of Britain. A dashed line, labeled 'Suggested undersea cable', curves from the southern coast of Iceland towards the northern coast of Britain, indicating the proposed route for an electricity cable. The labels 'Iceland' and 'Britain' are placed near their respective landmasses.

Discuss the advantages and disadvantages of the plan to build thousands of offshore wind turbines around Britain **and** the suggested electricity power link between Britain and Iceland.

.....

.....

.....

.....

.....

.....

.....

.....

.....

.....

.....

.....

.....

.....

.....

.....

.....

.....

.....

.....

.....

.....

(6)
(Total 9 marks)

30

A farmer has installed a biogas electricity generator on his farm. This device generates electricity by burning the methane gas produced from rotting animal waste. Methane is a greenhouse gas. When methane burns, carbon dioxide and water are produced.

The animal waste rots in an anaerobic digester. The digester and the generator are kept inside a farm building and cannot be seen from the outside.

(a) The animal waste used in the anaerobic digester is a *renewable* energy source.

What is meant by an energy source being *renewable*?

.....
.....

(1)

(b) Suggest **one** reason why farmers have been encouraged to install their own biogas generators.

.....
.....

(1)

(c) The farmer's monthly electricity bill using the mains electricity supply was £300. The biogas generator cost the farmer £18 000 to buy and install.

Assuming the biogas generator provides all of the farmer's electricity, what is the pay-back time for the generator?

.....

Pay-back time =

(1)

(d) It would have been cheaper for the farmer to have bought and installed a small wind turbine.

Give **two** advantages of using the biogas generator rather than a wind turbine, to generate the electricity used on the farm.

1

.....

2

.....

(2)
(Total 5 marks)

31

(a) The pie chart shows the energy sources used by one company to generate electricity.

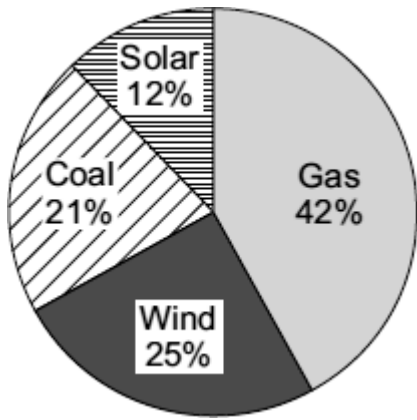

(i) Which two energy sources used by the company do **not** produce any polluting gases?

..... and

(1)

(ii) Calculate the percentage (%) of electricity that is generated using energy sources that do **not** produce any polluting gases.

Percentage =

(1)

(b) Which graph, **A**, **B** or **C**, is most likely to show the electrical power output from a wind turbine over one day?

Write your answer, **A**, **B** or **C**, in the box.

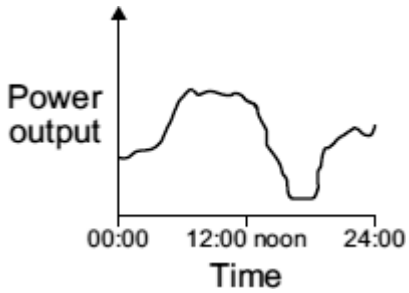

Graph A

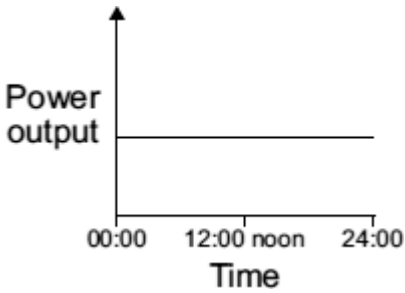

Graph B

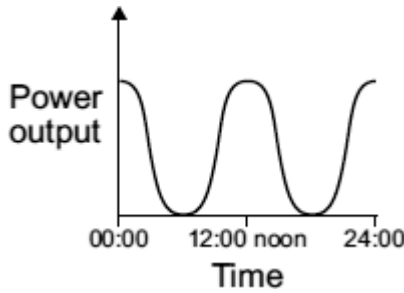

Graph C

Graph

(1)

- (c) The government has said that more electricity must be generated from renewable energy sources. A newspaper reported that:

**More wind farms, solar generators
and gas burning power stations
need to be built**

Why is the statement in the newspaper incorrect?

.....
.....

(1)
(Total 4 marks)

32

The diagram shows a small-scale, *micro-hydroelectricity* generator which uses the energy of falling river water to generate electricity. The water causes a device, called an Archimedean screw, to rotate.

The Archimedean screw is linked to the generator by a gearbox.

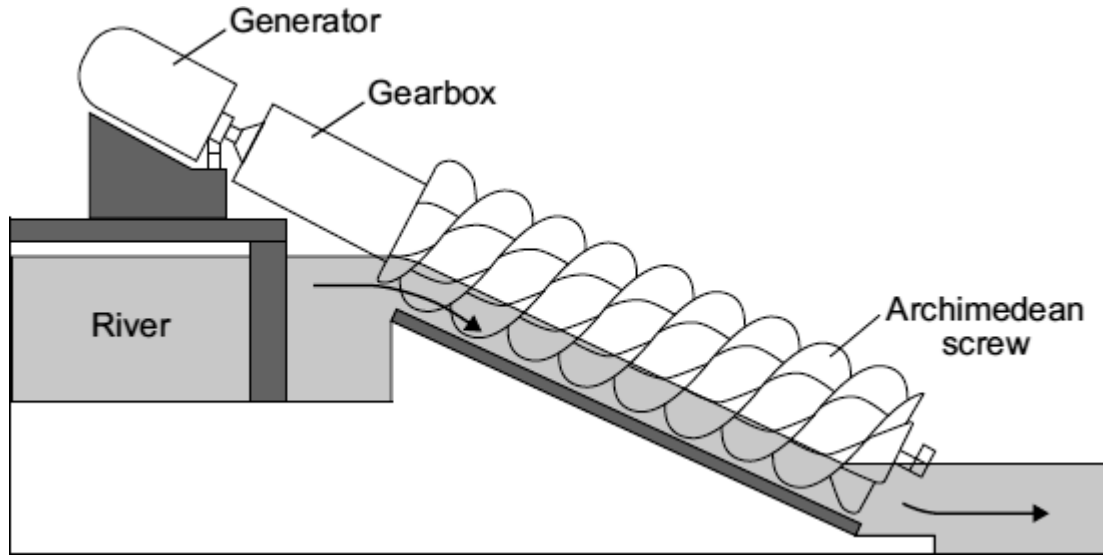

- (a) Complete the following sentence by drawing a ring around the correct word in the box.

The gravitational potential energy of the falling water is transformed

into the

chemical
electrical
kinetic

 energy of the Archimedean screw.

(1)

- (b) A micro-hydroelectric system generates about 60 kW of electricity, enough for 50 homes. A conventional large-scale hydroelectric power station may generate more than 5 000 000 kW of electricity.

- (i) Give **one** advantage of a conventional large-scale hydroelectric power station compared to a micro-hydroelectric system.

.....
.....

(1)

- (ii) Which **one** of the following statements gives a **disadvantage** of a conventional large-scale hydroelectric power station compared to a micro-hydroelectric system?

Put a tick (✓) in the box next to your answer.

Energy is wasted as heat and sound.

Large areas of land are flooded.

A constant flow of water is needed.

(1)

- (c) The electricity generated by the micro-hydroelectric system is transferred directly to local homes. The electricity generated by a conventional large-scale hydroelectric power station is transferred to homes anywhere in the country through a system of cables and transformers.

- (i) What name is given to the system of cables and transformers used to transfer electricity to homes anywhere in the country?

.....

(1)

- (ii) Using short cables to transfer electricity to local homes is much more efficient than using very long cables to transfer electricity to homes anywhere in the country.

Why?

.....

.....

(1)

- (d) Nepal is a mountainous country with over 6000 rivers. In Nepal, 9000 kW of electricity are generated using micro-hydroelectric generators.

Suggest **one** reason why in the UK much less electricity is generated using micro-hydroelectric generators, than in Nepal.

.....

.....

(1)
(Total 6 marks)

33

(a) An electricity company claims to generate all of its electricity from environmentally friendly energy sources.

The energy sources used by the company are shown in the pie chart.

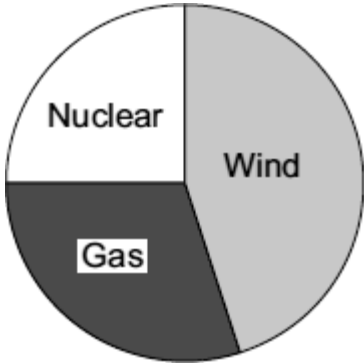

Do you think that the claim made by the company is correct?

Draw a ring around your answer.

Yes No Maybe

Explain the reasons for your answer.

.....
.....
.....
.....

(2)

(b) The government is committed to increasing the amount of electricity generated from renewable sources. A newspaper reported that:

More wind farms, wave powered generators, solar generators and nuclear power stations would need to be built

Why is the statement made in the newspaper incorrect?

.....
.....

(1)
(Total 3 marks)

34

The diagram shows a small-scale, *micro-hydroelectricity* generator which uses the energy of falling river water to generate electricity. The water causes a device, called an Archimedean screw, to rotate.

The Archimedean screw is linked to the generator by a gearbox.

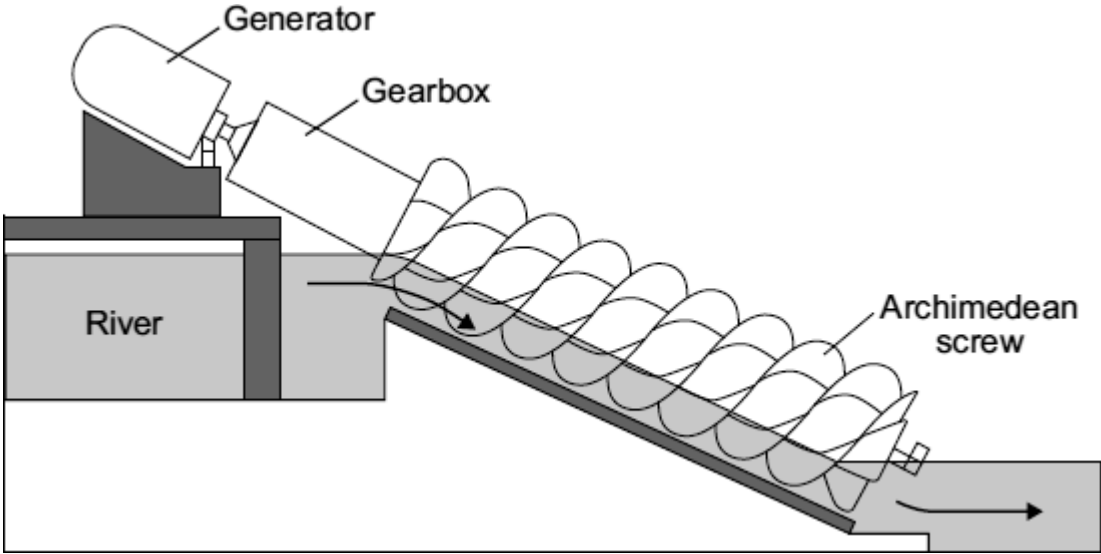

(a) Each second, the *micro-hydroelectricity* generator transforms 80 000 joules of gravitational potential energy into 60 000 joules of electrical energy.

(i) Fill in the missing word to complete the energy transformation diagram.

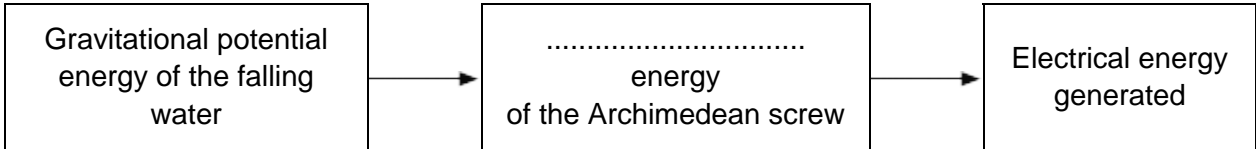

(1)

(ii) Use the equation in the box to calculate the efficiency of the *micro-hydroelectricity* generator.

$$\text{efficiency} = \frac{\text{useful energy transferred by the device}}{\text{total energy supplied to the device}}$$

Show clearly how you work out your answer.

.....
.....

Efficiency =

(2)

(b) The power output from a conventional large-scale hydroelectric power station is 100 000 times more than the power output from a micro-hydroelectric system.

Give **one** disadvantage of a conventional large-scale hydroelectric power station compared to the micro-hydroelectric system.

.....
.....

(1)

(c) The electricity generated by a micro-hydroelectric system is transferred via a transformer directly to local homes. The electricity generated by a conventional large-scale hydroelectric power station is transferred to the National Grid, which distributes the electricity to homes anywhere in the country.

(i) What is the National Grid?

.....
.....

(1)

(ii) Explain why transferring the electricity directly to local homes is more efficient than using the National Grid to distribute the electricity.

.....
.....
.....
.....

(2)

(Total 7 marks)

35

(a) By 2023, nearly all of the existing nuclear power stations in the UK will be closed down.

(i) Before a nuclear power station can be demolished, the remaining nuclear fuel, radioactive waste materials and reactor must be carefully removed.

What is this process called?

Put a tick (✓) in the box next to your answer.

decommissioning

decontaminating

dismantling

(1)

(ii) The workers are exposed to radiation as they remove the reactor. One of the biggest risks is from the isotope cobalt-60, which has a half-life of 5.3 years.

Explain the advantage of waiting 11 years after a nuclear power station has closed down before starting to remove the reactor.

.....
.....
.....
.....

(2)

(b) It is almost certain that new nuclear power stations will be built in the UK.

The table shows the results of surveys asking people in the UK whether they were in favour of, or against, the building of new nuclear power stations.

	2001	2005	2007
Percentage (%) in favour	20	41	65
Percentage (%) against	60	28	20
Percentage (%) not sure	20	31	15

(i) From these surveys, how did public opinion on the building of new nuclear power stations change between 2001 and 2007?

.....
.....

(1)

(ii) Suggest a reason why some people may think that the results from these surveys are unreliable.

.....
.....

(1)

(iii) Give **one** reason in favour of building new nuclear power stations.

.....
.....

(1)

- (c) The government of one Middle Eastern country has decided to build its first nuclear power station. The oil that would have been used to generate electricity can then be sold to other countries.

On what is this decision based?

Put a tick (✓) in the box next to your answer.

economic issues

ethical issues

social issues

(1)
(Total 7 marks)

36

- (a) The diagram shows a solar powered device being used to recharge a mobile phone.

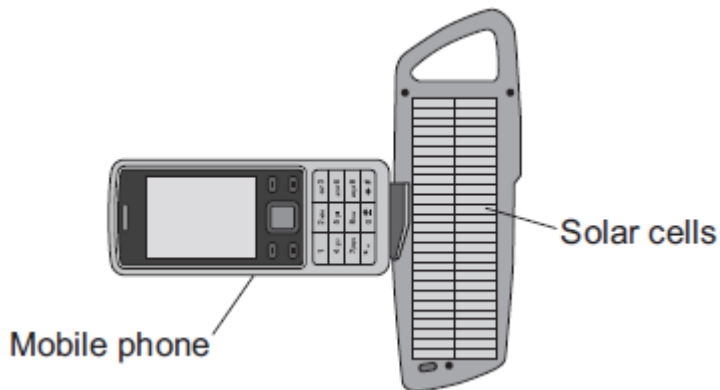

On average, the solar cells produce 0.6 joules of electrical energy each second. The solar cells have an efficiency of 0.15.

- (i) Calculate the average energy input each second to the device.

Show clearly how you work out your answer.

.....
.....

Average energy input each second = J/s

(2)

- (ii) Draw a labelled Sankey diagram for the solar cells.
The diagram does **not** need to be drawn to scale.

(1)

- (b) Scientists have developed a new type of solar cell with an efficiency of over 40 %.
The efficiency of the solar cell was confirmed independently by other scientists.

Suggest why it was important to confirm the efficiency independently.

.....

.....

(1)

- (c) The electricity used in homes in the UK is normally generated in a fossil fuel power station.
Outline some of the advantages of using solar cells to generate this electricity.

.....

.....

.....

.....

(2)

(Total 6 marks)

37

(a) Most electricity in the UK is generated in power stations that burn fossil fuels.

The bar chart shows how much carbon dioxide is produced for each kilowatt-hour of electricity generated using a fossil fuel.

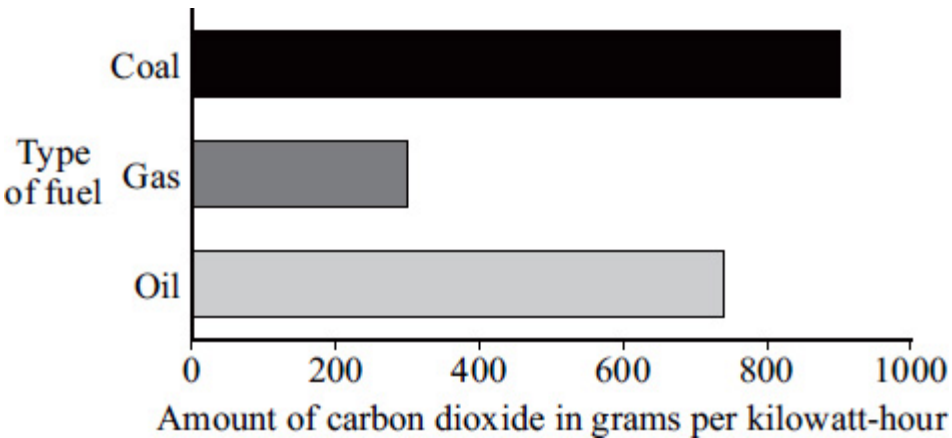

(i) Which fossil fuel produces the smallest amount of carbon dioxide for each kilowatt-hour of electricity generated?

.....

(1)

(ii) Which **one** of the following statements gives the reason why the data has been shown as a bar chart and not as a line graph?

Put a tick (✓) in the box next to your answer.

- Both variables are categoric.
- Both variables are continuous.
- One variable is categoric, the other is continuous.

(1)

(iii) Why does a nuclear power station **not** produce any carbon dioxide?

.....
.....

(1)

(b) Some types of power station generate electricity by burning straw.

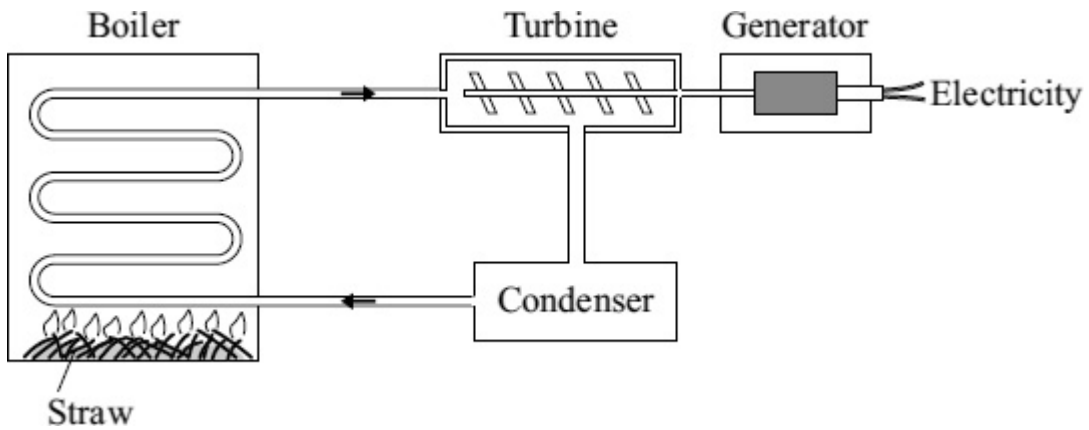

(i) Use words from the box to complete the following sentences.

boiler gas generator steam turbine water

Straw is burned in a Water is heated to make
 which is used to drive a
 This turns a to produce electricity.

(4)

(ii) Straw is a type of renewable energy source known as a biofuel.

Name **one** other type of renewable energy source used to produce electricity.

.....

(1)

(iii) A power station generates 36 000 000 watts (36 MW) of electrical power by burning straw. The average power used in each home in the UK over one year is 2000 watts.

Calculate the number of homes that the power station could supply electricity to.

Show clearly how you work out your answer.

.....

Number of homes =

(2)

(Total 10 marks)

38

Over the next 15 years, some of the older nuclear power stations will be closed down, and the process of *decommissioning* will start. In the same period, several countries plan to build a number of new nuclear power stations.

(a) (i) What does it mean to *decommission* a nuclear power station?

.....
.....

(1)

(ii) How does *decommissioning* affect the overall cost of electricity generated using nuclear fuels?

.....
.....

(1)

(b) Uranium is a fuel used in nuclear power stations to generate electricity.

Graph 1 compares how the electricity generated from one kilogram of nuclear fuel changed between 1980 and 2005 in three different types of nuclear power station.

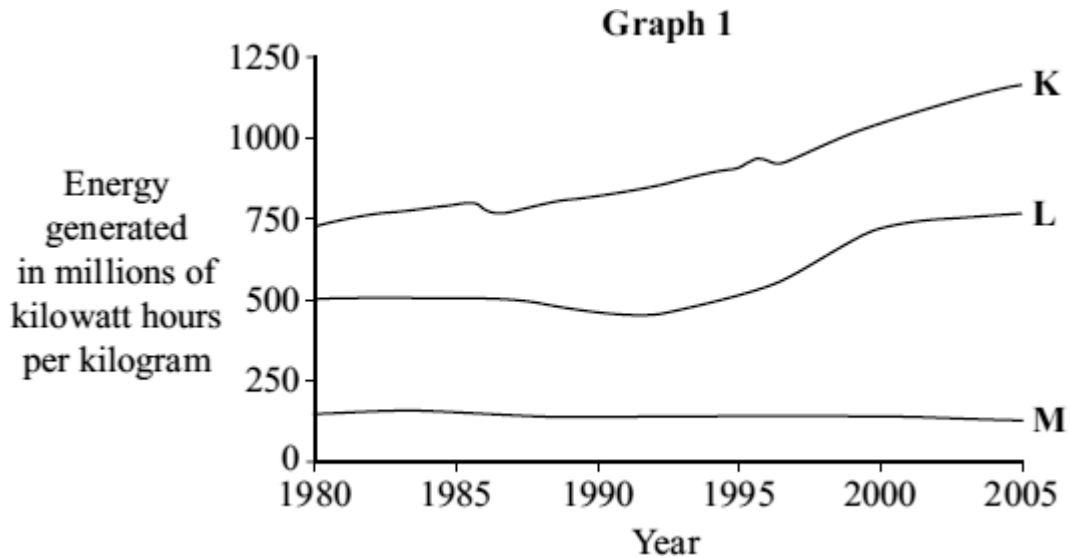

(i) Compare the efficiency of the three types of power station, **K**, **L** and **M**, between 1980 and 2005.

.....
.....
.....
.....

(2)

Graph 2 shows two different predictions for the global growth in uranium demand over the next few years.

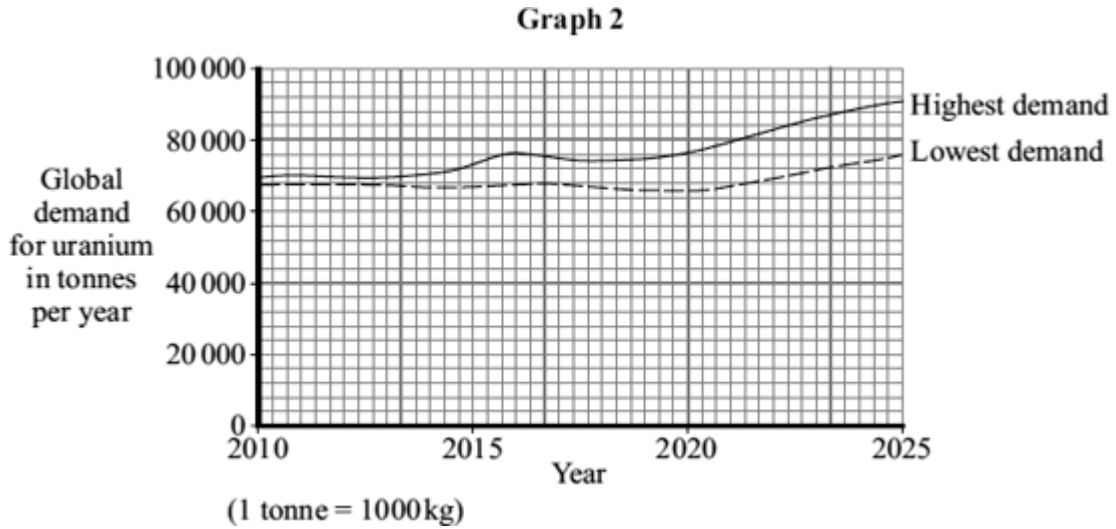

(ii) Suggest reasons why it is **not** possible to predict accurately how much uranium will be needed in 2025.

.....

.....

.....

.....

(2)
(Total 6 marks)

39

Four students are talking about the different energy sources used to generate electricity in the areas where they live.

(a) Draw **one** line from where each student lives (**List A**) to the energy source in their area (**List B**).

Draw only **four** lines.

List A
Where each student lives

List B
Energy source

Where I live is the sunniest part of the country.

Wind

Where I live, the land is very flat and it always seems to be windy.

Waves

Where I live, it is not safe to swim. The sea is always too rough.

Solar

Where I live, you can see steam coming out of the ground.

Tides

Geothermal

(4)

(b) All of the energy sources given in part (a) can be used to generate electricity.

What else do all these energy sources have in common?

.....
.....

(1)

(c) In a hydroelectric power station, the energy from falling water is used to generate electricity.

Which **one** of the following gives a **disadvantage** of a hydroelectric power station?

Put a tick (✓) in the box next to your answer.

has a fast start-up time

large areas of land are flooded

polluting gases are produced

(1)
(Total 6 marks)

40

The map shows the positions of two towns on either side of a very large coastal bay in England. The map also shows where a bridge may be built to link the towns. The road journey from one town to the other is about 60 kilometres at present.

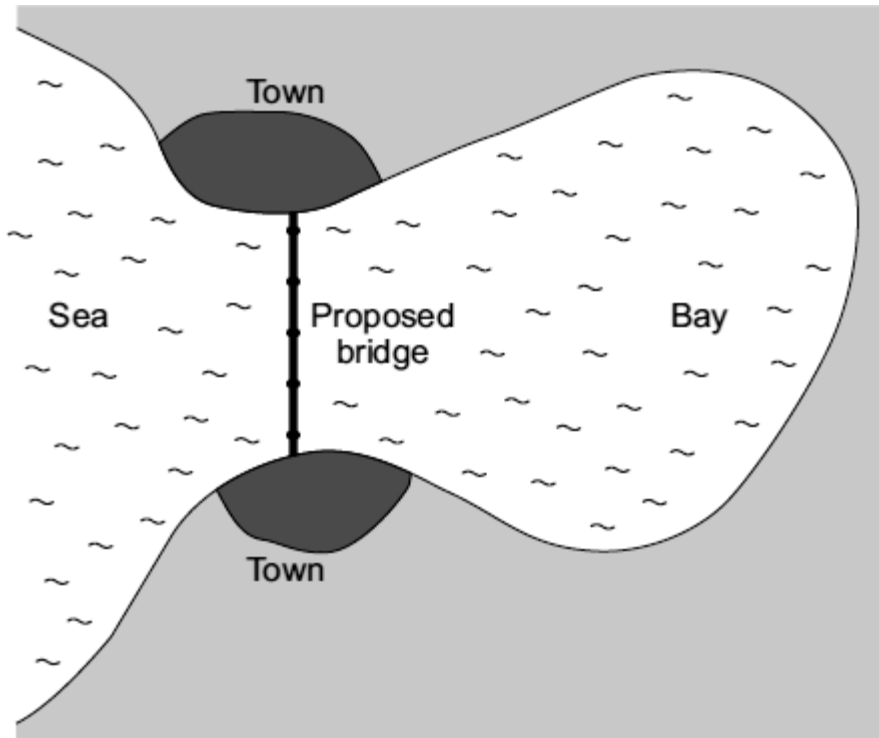

(a) It is estimated that building turbines and generators inside the legs of the bridge would produce enough electricity for both towns. In addition, enough electricity would be generated to run electric buses over the bridge between the two towns.

(i) If the bridge is built, what form of renewable energy will be used to generate the electricity?

.....

(1)

(ii) Most people living in the area are in favour of the proposed bridge.

Suggest **three** reasons why people would be in favour of building the bridge and the associated electricity generating scheme.

Reason 1

.....

Reason 2

.....

Reason 3

.....

(3)

- (b) Even with the proposed bridge, the two towns will need to stay connected to the National Grid.

The diagram shows part of the National Grid.

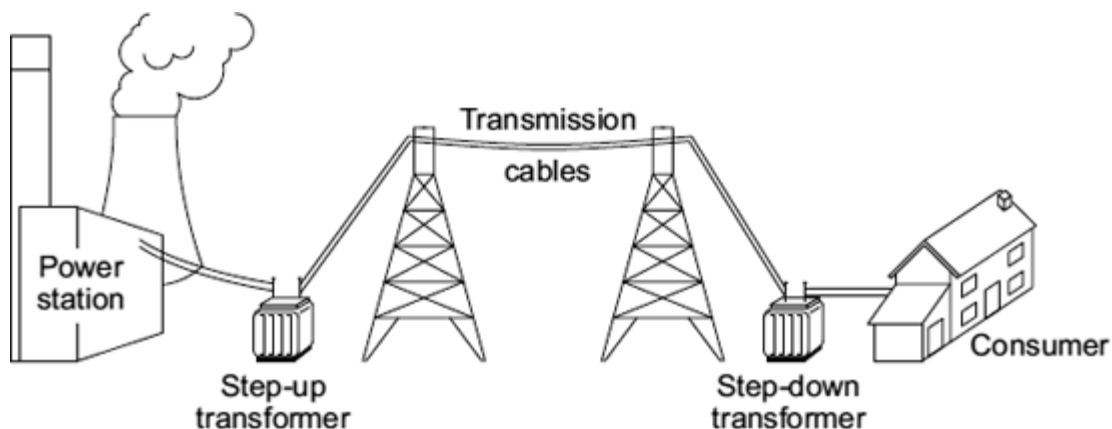

- (i) Give **one** reason why the towns need to stay connected to the National Grid.

.....
.....

(1)

- (ii) Explain how the step-up transformer increases the efficiency of the National Grid.

.....
.....
.....
.....

(2)

(Total 7 marks)

41

The picture shows a solar-powered aircraft. The aircraft has no pilot.

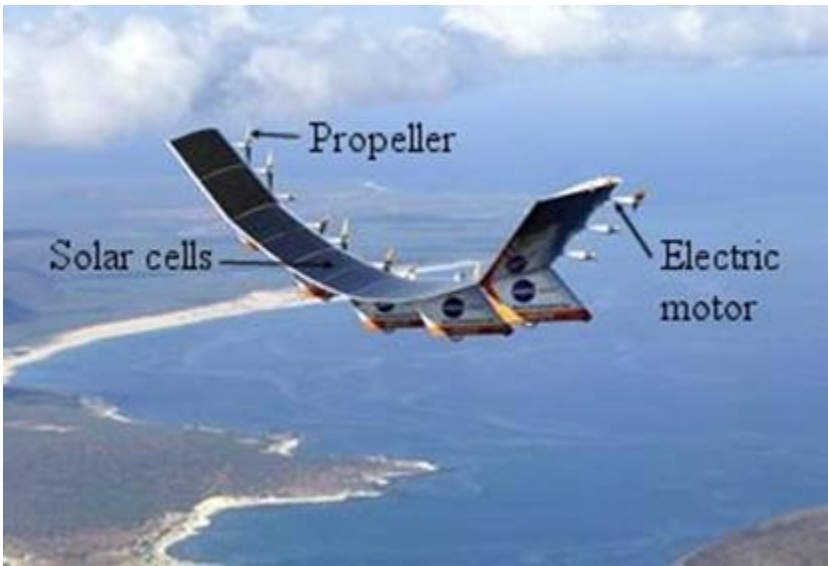

Photo by NASA.

- (a) On a summer day, 175 000 joules of energy are supplied to the aircraft's solar cells every second. The useful energy transferred by the solar cells is 35 000 joules every second.
 - (i) Use the equation in the box to calculate the efficiency of the solar cells.

$$\text{efficiency} = \frac{\text{useful energy transferred by the device}}{\text{total energy supplied to the device}}$$

Show clearly how you work out your answer.

.....

.....

Efficiency =

(2)

- (ii) What happens to the energy that is **not** usefully transferred by the solar cells?

.....

(1)

- (b) The aircraft propellers are driven by electric motors. As well as the solar cells, there are fuel cells that provide additional power to the electric motors.

- (i) Suggest **one** advantage of the aircraft having fuel cells as well as the solar cells.

.....

(1)

- (ii) Give **one** environmental advantage of using electric motors to drive the aircraft propellers rather than motors that burn a fuel.

.....
.....

(1)

- (iii) Eventually, the designers want to produce an unmanned aircraft that can fly at twice the height of a passenger jet for up to six months.

Suggest **one** possible use for an aircraft such as this.

.....
.....

(1)
(Total 6 marks)

42

The bar chart shows the different energy sources used to generate the UK's electricity in 2007.

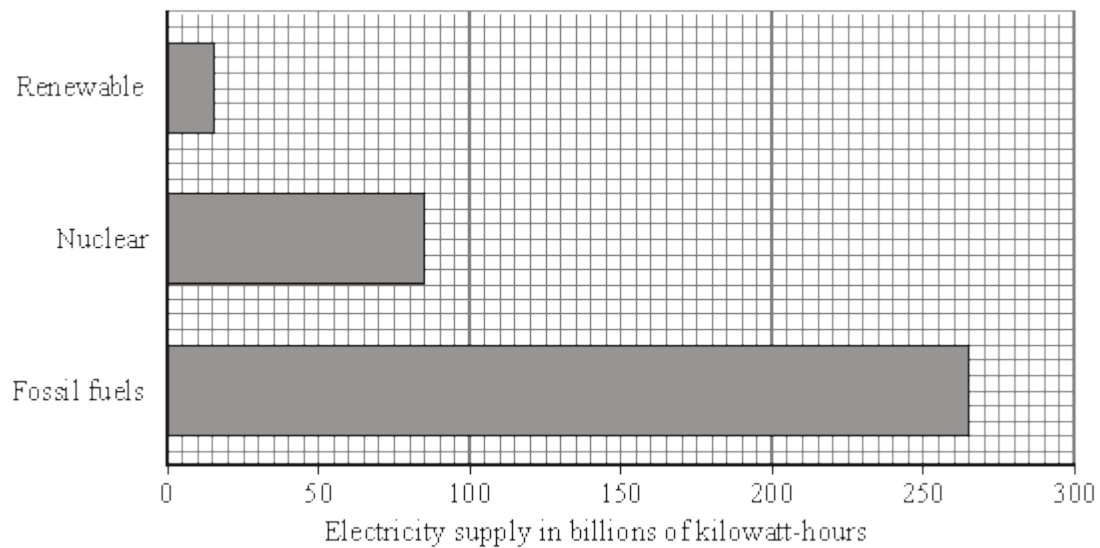

(a) (i) The wind is a renewable energy source.

Name **one** more renewable energy source used to generate electricity.

.....

(1)

(ii) Complete the following sentence by drawing a ring around the correct line in the box.

Using less fossil fuels to generate electricity will

decrease

not change

increase

the

amount of carbon dioxide emitted into the atmosphere.

(1)

(b) The graph shows how the demand for electricity in the UK varied over one day in the winter.

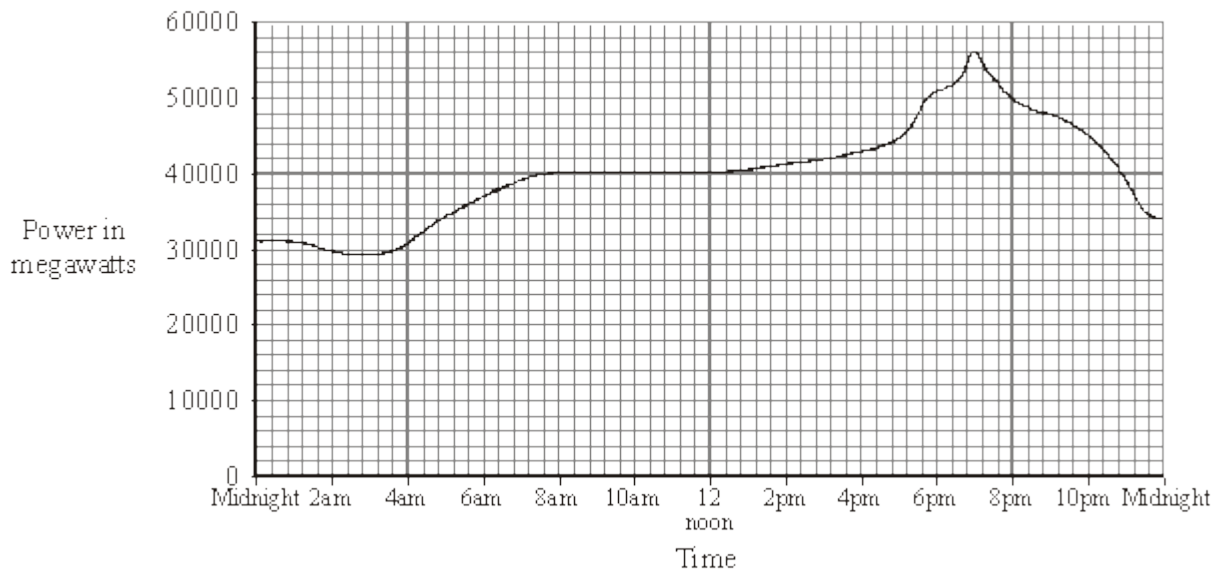

(i) Describe how the demand for electricity varied between 4.00 am and 10.00 am.

.....
.....
.....
.....

(2)

(ii) Which type of power station has the fastest start-up time?

Draw a ring around your answer.

coal natural gas nuclear oil

(1)
(Total 5 marks)

43

The bar chart shows how the UK's electricity demands in 2007 were met.

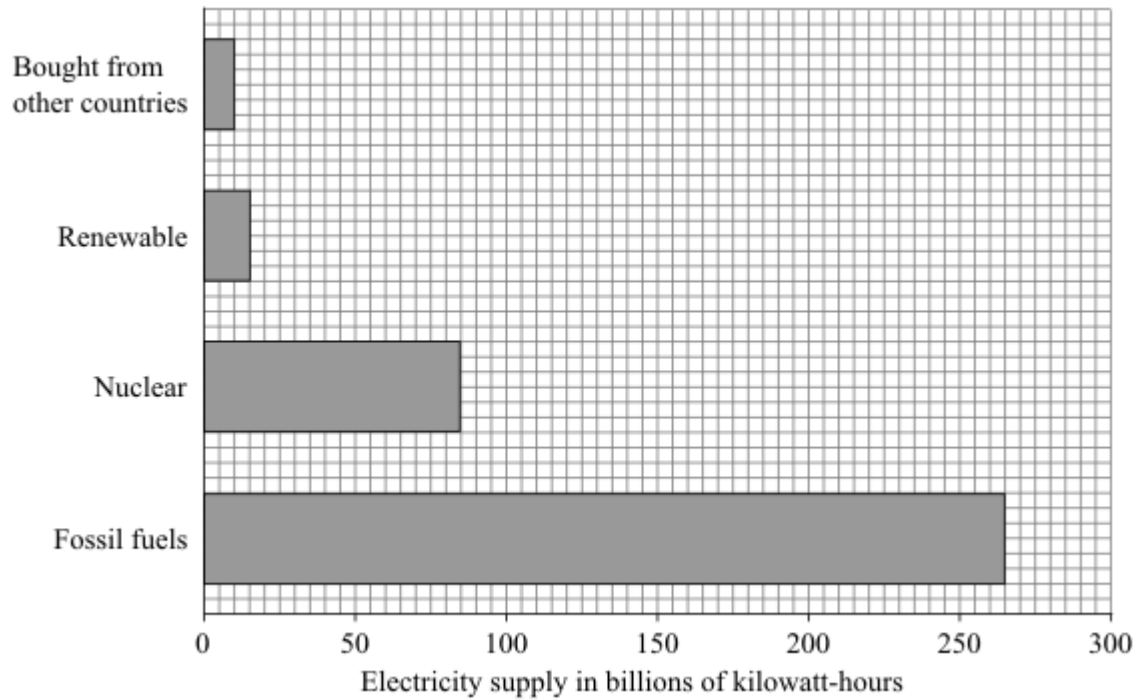

(a) What proportion of electricity was generated using renewable energy sources?

Show clearly how you work out your answer.

.....

.....

.....

.....

(2)

- (b) By 2020, most of the UK's nuclear reactors and one-third of coal-fired power stations are due to close, yet the demand for electricity is expected to increase.

Four students, **A**, **B**, **C** and **D**, were asked how a demand of 380 billion kilowatt-hours could be met. They made the suggestions given in the table.

Student	Fossil fuels	Nuclear	Renewable	Bought from other countries
A	200	100	40	40
B	80	240	40	20
C	160	80	100	40
D	280	0	100	0

- (i) Which student has made the suggestion most likely to result in the lowest carbon dioxide emissions?

.....

Give a reason for your answer.

.....

.....

(2)

- (ii) Suggest **one** realistic way in which a householder could help to reduce the annual electricity demand.

.....

.....

(1)

- (c) To increase the amount of electricity generated using renewable energy resources would probably involve erecting many new wind turbines.

The graph shows the power curve of a wind turbine.

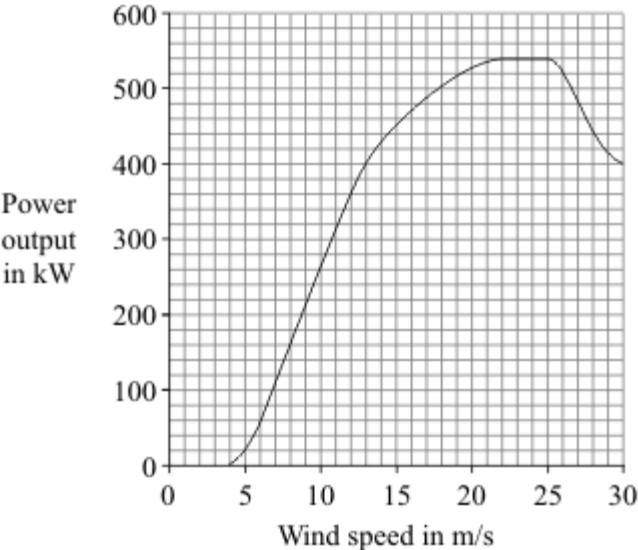

- (i) Describe, in detail, how the power output of the turbine varies with the wind speed.

.....

.....

.....

.....

.....

.....

(3)

- (ii) Give **one** disadvantage of using wind turbines to generate a high proportion of the electricity required in the UK.

.....

.....

(1)

(Total 9 marks)