

1

Figure 1 shows the construction of a simple transformer.

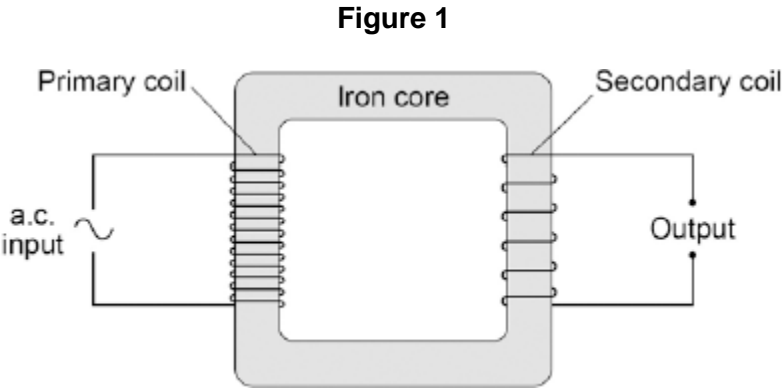

(a) Why is iron a suitable material for the core of a transformer?

Tick **one** box.

It is a metal.

It will not get hot.

It is easily magnetised.

It is an electrical conductor.

(1)

- (b) A student makes three simple transformers, **J**, **K** and **L**.

**Figure 2** shows how the potential difference across the secondary coil of each transformer varies as the potential difference across the primary coil of each transformer is changed.

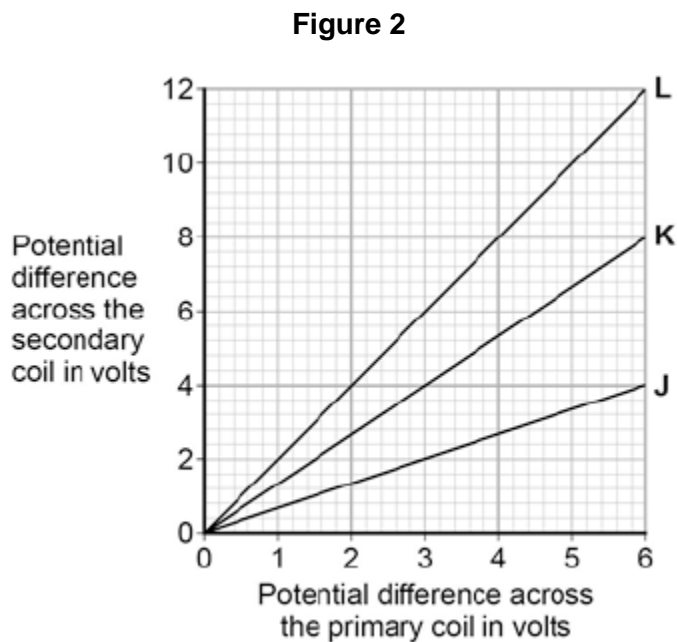

How can you tell that transformer **J** is a step-down transformer?

---



---

(1)

- (c) Each of the transformers has 50 turns on the primary coil.

Calculate the number of turns on the secondary coil of transformer **L**.

Use the correct equation from the Physics Equations Sheet.

---



---



---

Number of turns on the secondary coil = \_\_\_\_\_

(3)

(Total 5 marks)

2

Figure 1 shows the structure of a traditional transformer.

Figure 1

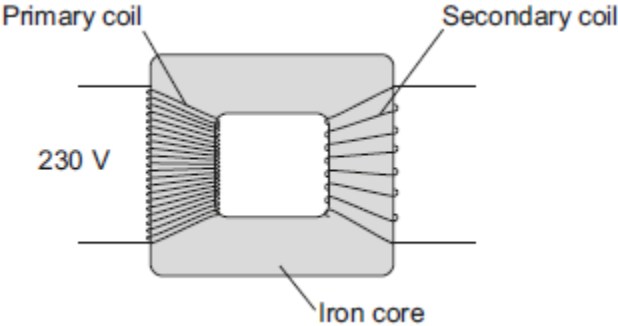

(a) There is an alternating current in the primary coil of the transformer.

State what is produced in the iron core.

---

---

(2)

(b) A transformer has only **one** turn of wire on the secondary coil.  
The potential difference across the secondary coil is 11.5 V  
The potential difference across the primary coil is 230 V

Calculate the number of turns on the primary coil.

---

---

---

---

Number of turns on the primary coil = \_\_\_\_\_

(2)

(c) In most transformers, the power output is less than the power input.

State why.

---

---

(1)

- (d) Two students investigated how magnets can be used to produce a potential difference. The students held a coil of wire above a magnet. The students quickly lowered the coil so that the magnet was inside the coil, as shown in **Figure 2**.

**Figure 2**

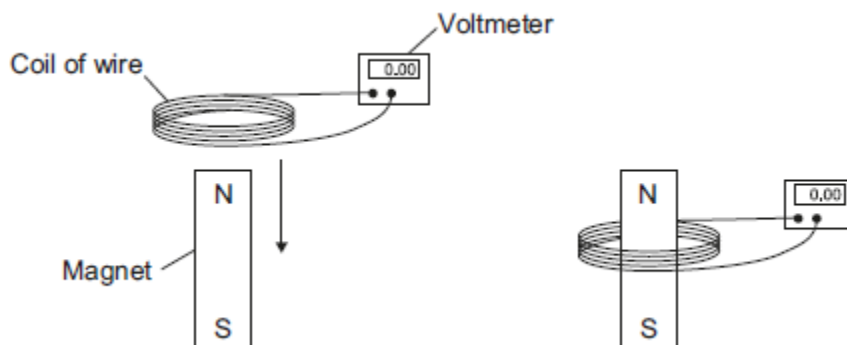

The students recorded the maximum potential difference for coils with different numbers of turns of wire. The results are shown in the table.

| Number of turns of wire in the coil | Maximum potential difference in volts |                        |
|-------------------------------------|---------------------------------------|------------------------|
|                                     | Results from student 1                | Results from student 2 |
| 5                                   | 0.09                                  | 0.08                   |
| 10                                  | 0.20                                  | 0.15                   |
| 15                                  | 0.31                                  | 0.25                   |
| 20                                  | 0.39                                  | 0.33                   |
| 25                                  | 0.51                                  | 0.39                   |

- (i) State the resolution of the voltmeter.

Give **one** reason why the resolution of the voltmeter is suitable for this investigation.

Resolution \_\_\_\_\_

Reason \_\_\_\_\_

\_\_\_\_\_

(2)

- (ii) The two students used exactly the same equipment to carry out their investigations. Both students recorded their results correctly.

Give the reason why student 2 got different results from student 1.

---

---

(1)

- (iii) The students decided that even though the results were different, there was no need to repeat the investigation.

How do the results show that the investigation is reproducible?

---

---

(1)

- (iv) State the name of the process which causes the potential difference to be produced in this investigation.

---

(1)

- (e) A transformer has been developed that can be used with many different devices.

Suggest **one** advantage of having a transformer that can be used with many different devices.

---

---

(1)

(Total 11 marks)

3

Transformers are used to change potential differences (p.d.) in the National Grid.

Figure 1 shows a step-up transformer that is used at a power station.

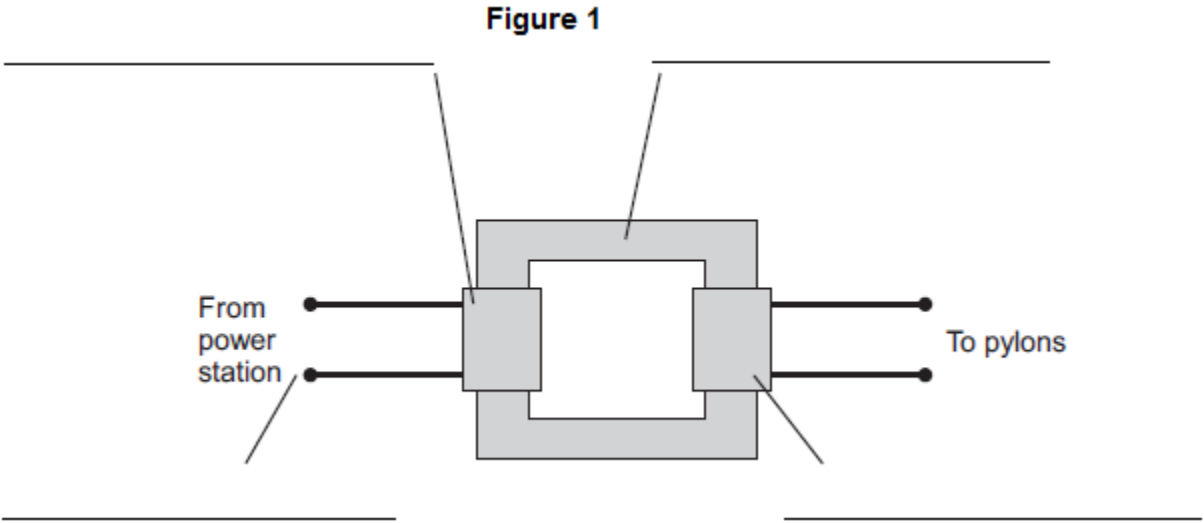

(a) (i) Use words from the box to label **Figure 1**.

|              |           |                |
|--------------|-----------|----------------|
| Input p.d.   | Iron core | Output p.d.    |
| Primary coil |           | Secondary coil |

(4)

(ii) One of the coils in **Figure 1** has a p.d. of 25 kV across it and has 1000 turns.

The other coil has a p.d. of 400 kV across it.

Calculate the number of turns on this other coil.

---

---

---

---

Number of turns = \_\_\_\_\_

(2)

(iii) Explain why a step-up transformer is used at a power station.

---

---

---

---

---

---

---

(3)

(b) **Figure 2** shows a mobile phone charger.

**Figure 2**



The charger contains a step-down transformer. A switch mode transformer is used rather than a traditional transformer.

Describe the advantages of using a switch mode transformer in the charger rather than a traditional transformer.

---

---

---

---

---

---

---

(3)

(Total 12 marks)

4

Figure 1 shows a traditional transformer.

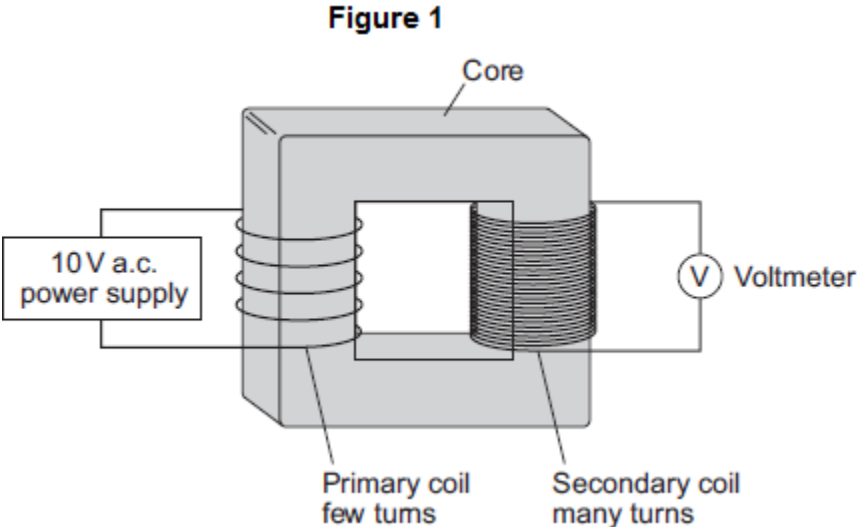

(a) (i) Which metal should the core of the transformer be made from?

Tick (✓) **one** box.

- aluminium
- copper
- iron

(1)

(ii) What would the reading be on the voltmeter shown in **Figure 1**?

Draw a ring around the correct answer.

- 2 V**
- 10 V**
- 50 V**

Give the reason for your answer.

---

---

(2)



(b) **Figure 2** shows a tablet computer and its charger.

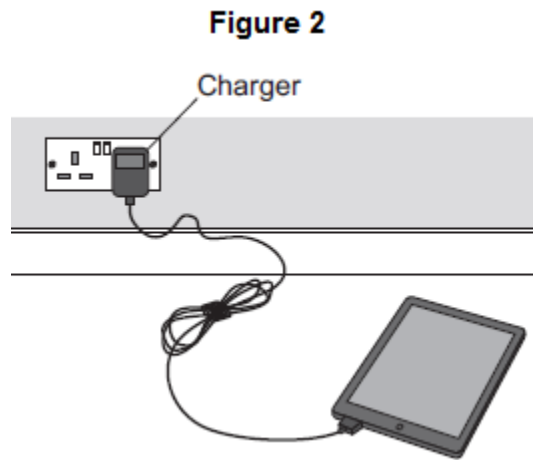

The charger contains a switch mode transformer.

(i) Use the correct answer from the box to complete the sentence.

|            |             |               |
|------------|-------------|---------------|
| <b>200</b> | <b>1000</b> | <b>20 000</b> |
|------------|-------------|---------------|

Switch mode transformers operate at frequencies

from 50 kHz to \_\_\_\_\_ kHz.

(1)

(ii) Give **one** advantage of a switch mode transformer over a traditional transformer.

---

---

(1)

(Total 5 marks)

5

An electric toothbrush is charged by standing it on a separate charging base. The diagram shows the inside of the electric toothbrush and the charging base.

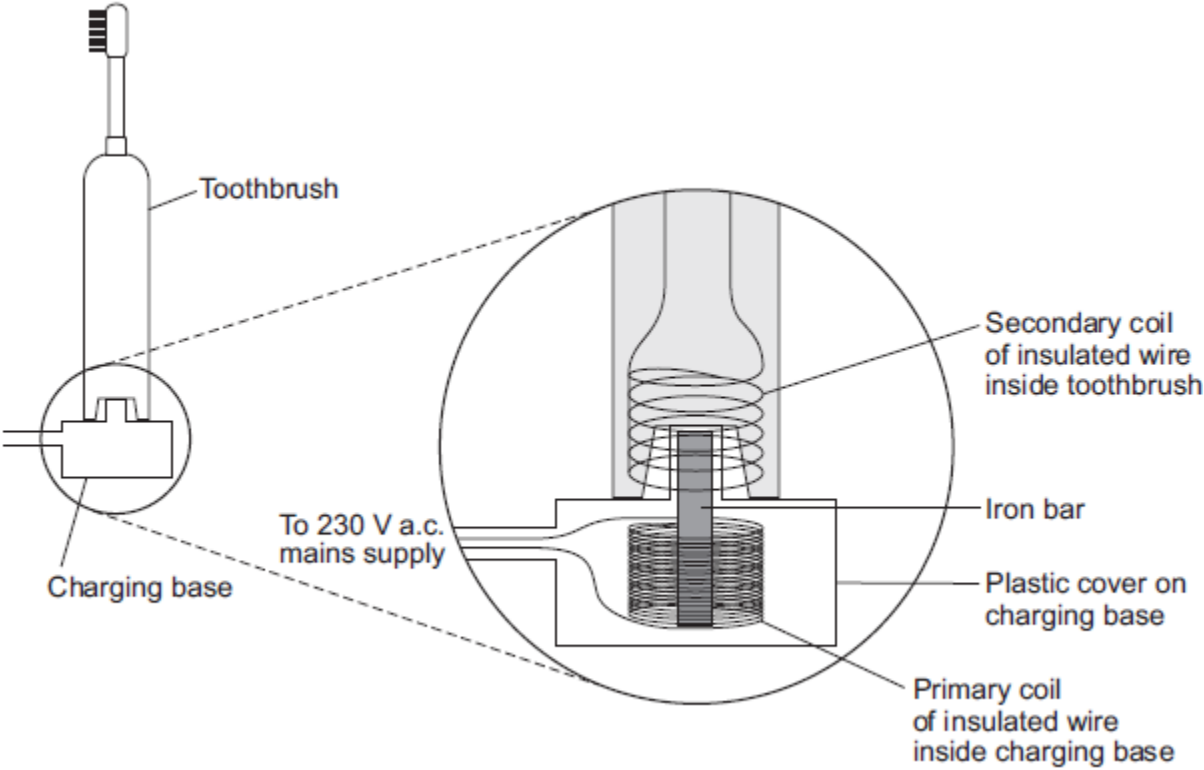

(a) An alternating potential difference (p.d.) across the coil in the charging base creates an alternating current in the coil inside the toothbrush.

Explain how.

---

---

---

---

---

---

---

---

---

---

(3)

- (b) When the toothbrush is being charged, the p.d. across the primary coil in the charging base is 230 V.

The charging p.d. across the secondary coil in the toothbrush is 7.2 V.

The primary coil in the charging base has 575 turns of wire on its coil.

Calculate the number of turns on the secondary coil inside the toothbrush.

---

---

---

---

Number of turns on the secondary coil = \_\_\_\_\_

(2)

(Total 5 marks)

6

The diagram shows an a.c. generator.

The coil rotates about the axis shown and cuts through the magnetic field produced by the magnets.

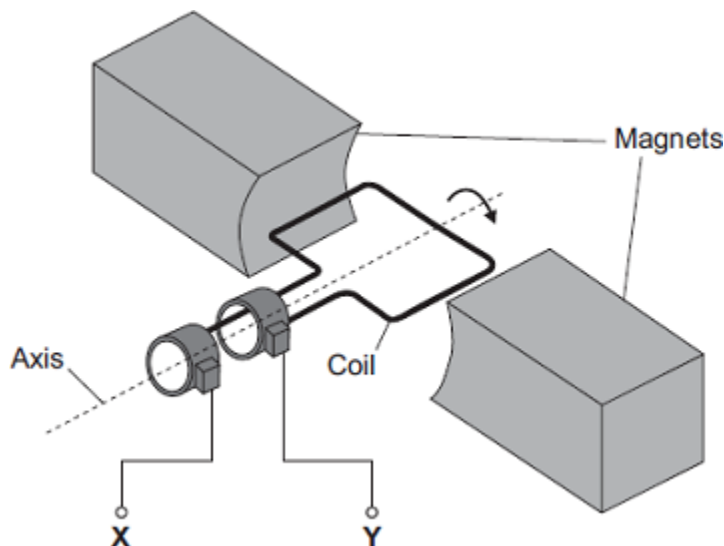

- (a) (i) A potential difference is induced between X and Y.

Use the correct answer from the box to complete the sentence.

|                 |                  |              |                    |
|-----------------|------------------|--------------|--------------------|
| <b>electric</b> | <b>generator</b> | <b>motor</b> | <b>transformer</b> |
|-----------------|------------------|--------------|--------------------|

This effect is called the \_\_\_\_\_ effect.

(1)

(ii) What do the letters a.c. stand for?

\_\_\_\_\_

(1)

(iii) Name an instrument that could be used to measure the potential difference between **X** and **Y**.

\_\_\_\_\_

(1)

(b) **Graph 1** shows the output from the a.c. generator.

**Graph 1**

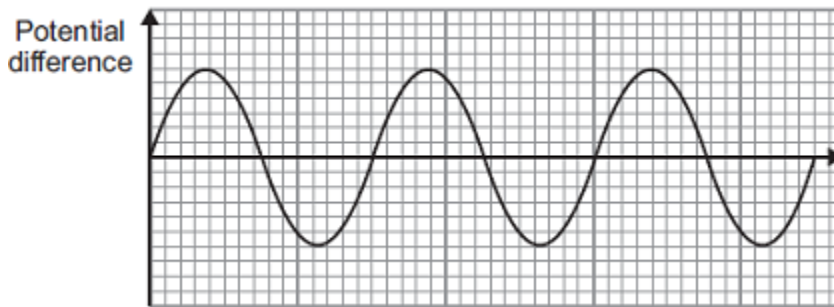

(i) One of the axes on **Graph 1** has been labelled 'Potential difference'.

What should the other axis be labelled?

\_\_\_\_\_

(1)

(ii) The direction of the magnetic field is reversed.

On **Graph 1**, draw the output from the a.c. generator if everything else remains the same.

(2)

(c) The number of turns of wire on the coil is increased. This increases the maximum induced potential difference.

State **two** other ways in which the maximum induced potential difference could be increased.

1. \_\_\_\_\_

\_\_\_\_\_

2. \_\_\_\_\_

\_\_\_\_\_

(2)

(Total 8 marks)

7

The current in a circuit depends on the potential difference (p.d.) provided by the cells and the total resistance of the circuit.

(a) Using the correct circuit symbols, draw a diagram to show how you would connect 1.5 V cells together to give a p.d. of 6 V.

(2)

(b) **Figure 1** shows a circuit containing an 18 V battery.

Two resistors, **X** and **Y**, are connected in series.

- **X** has a resistance of 3 Ω.
- There is a current of 2 A in **X**.

**Figure 1**

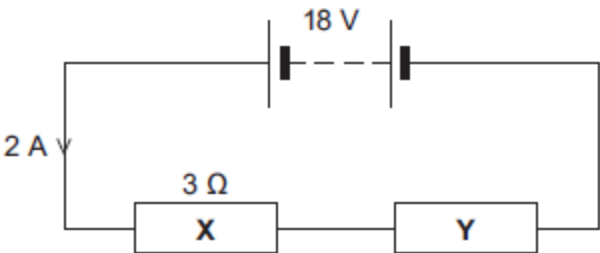

(i) Calculate the p.d. across **X**.

---

---

P.d. across **X** = \_\_\_\_\_ V

(2)

(ii) Calculate the p.d. across **Y**.

---

---

---

P.d. across **Y** = \_\_\_\_\_ V

(2)

(iii) Calculate the total resistance of **X** and **Y**.

---

---

---

Total resistance of **X** and **Y** = \_\_\_\_\_ Ω

(2)

(c) **Figure 2** shows a transformer.

**Figure 2**

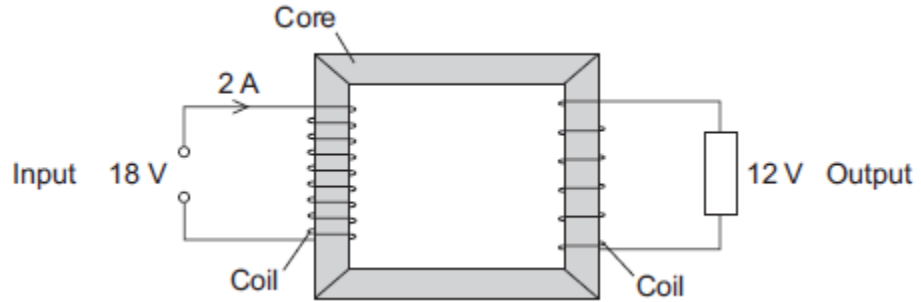

(i) An 18 V battery could **not** be used as the input of a transformer.

Explain why.

---

---

---

---

(2)

(ii) The transformer is 100% efficient.

Calculate the output current for the transformer shown in **Figure 2**.

---

---

---

Output current = \_\_\_\_\_ A

(2)

(Total 12 marks)



(b) The table below shows some other actions taken by the teacher.

Complete the table to show the effect of each action on the ammeter reading.

| Action taken by teacher  | What happens to the ammeter reading? |
|--|--------------------------------------|
| Holds the magnet stationary and moves the coil slowly towards the magnet |                                      |
| Holds the magnet stationary within the coil                              |                                      |
| Moves the magnet quickly towards the coil                                |                                      |
| Reverses the magnet and moves it slowly towards the coil                 |                                      |

(4)

(c) The magnet moves so that there is a steady reading of 0.05 A on the ammeter for 6 seconds.

Calculate the charge that flows through the coil during the 6 seconds.

Give the unit.

---

---

---

Charge = \_\_\_\_\_

(3)

(Total 13 marks)



**9**

If a fault develops in an electrical circuit, the current may become too great. The circuit needs to be protected by being disconnected.

A fuse or a circuit breaker may be used to protect the circuit.  
One type of circuit breaker is a Residual Current Circuit Breaker (RCCB).

(a) (i) Use the correct answer from the box to complete the sentence.

|              |             |                |
|--------------|-------------|----------------|
| <b>earth</b> | <b>live</b> | <b>neutral</b> |
|--------------|-------------|----------------|

A fuse is connected in the \_\_\_\_\_ wire.

**(1)**

(ii) Use the correct answer from the box to complete the sentence.

|                   |                    |                     |
|-------------------|--------------------|---------------------|
| <b>are bigger</b> | <b>are cheaper</b> | <b>react faster</b> |
|-------------------|--------------------|---------------------|

RCCBs are sometimes preferred to fuses because they \_\_\_\_\_ .

**(1)**

(iii) RCCBs operate by detecting a difference in the current between two wires.

Use the correct answer from the box to complete the sentence.

|                       |                          |                         |
|-----------------------|--------------------------|-------------------------|
| <b>earth and live</b> | <b>earth and neutral</b> | <b>live and neutral</b> |
|-----------------------|--------------------------|-------------------------|

The two wires are the \_\_\_\_\_ wires.

**(1)**

(b) An RCCB contains an iron rocker and a coil.

A student investigated how the force of attraction, between a coil and an iron rocker, varies with the current in the coil.

She supported a coil vertically and connected it in an electrical circuit, part of which is shown in the figure below .

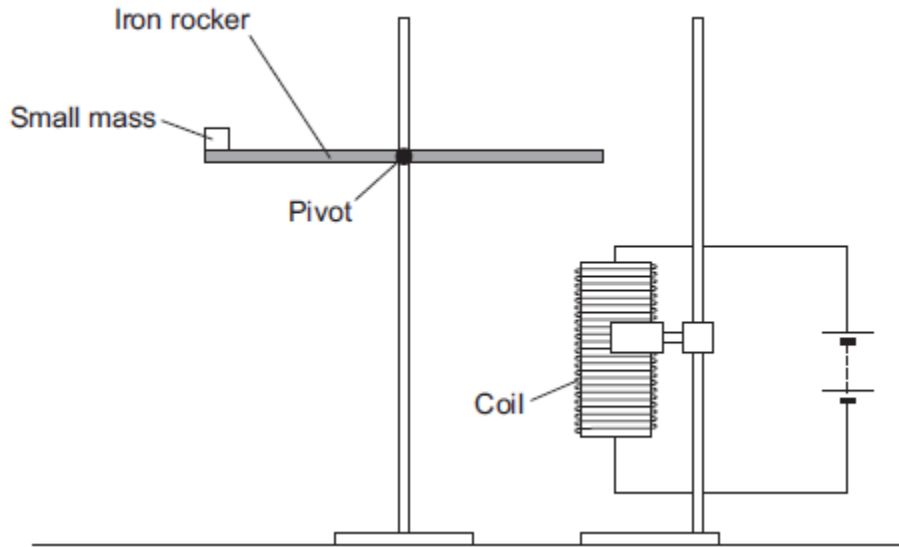

She put a small mass on the end of the rocker and increased the current in the coil until the rocker balanced. She repeated the procedure for different masses.

Some of her results are shown in the table below.

| <b>Mass in grams</b> | <b>Current needed for the rocker to balance in amps</b> |
|----------------------|---|
| 5                    | 0.5   |
| 10                   | 1.0   |
| 15                   | 1.5   |
| 20                   | 2.0   |

- (i) State **two** extra components that must have been included in the circuit in the figure above to allow the data in the above table to be collected.

Give reasons for your answers.

---

---

---

---

---

---

---

---

---

---

**(4)**

- (ii) A teacher said that the values of current were too high to be safe.

Suggest **two** changes that would allow lower values of current to be used in this investigation.

Change 1 \_\_\_\_\_

---

Change 2 \_\_\_\_\_

---

**(2)**

**(Total 9 marks)**



11

The diagram shows a transformer with a 50 Hz (a.c.) supply connected to 10 turns of insulated wire wrapped around one side of the iron core.

A voltmeter is connected to 5 turns wrapped around the other side of the iron core.

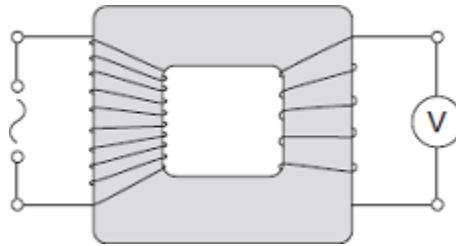

(a) What type of transformer is shown in the diagram?

Draw a ring around the correct answer.

**step-down**

**step-up**

**switch mode**

(1)

(b) The table shows values for the potential difference (p.d.) of the supply and the voltmeter reading.

| p.d. of the supply in volts | Voltmeter reading in volts |
|-----------------------------|----------------------------|
| 6.4                         | 3.2                        |
| 3.2                         |                            |
|                             | 6.4                        |

(i) Complete the table.

(2)

(ii) Transformers are used as part of the National Grid.

How are the values of p.d. in the table different to the values produced by the National Grid?

---

---

(1)

(c) Transformers will work with an alternating current (a.c.) supply but will **not** work with a direct current (d.c.) supply.

(i) Describe the difference between a.c. and d.c.

---

---

---

---

**(2)**

(ii) Explain how a transformer works.

---

---

---

---

---

---

---

---

---

---

**(4)**

**(Total 10 marks)**

12

(a) The diagram shows the structure of a traditional transformer.

Use words from the box to label the diagram.

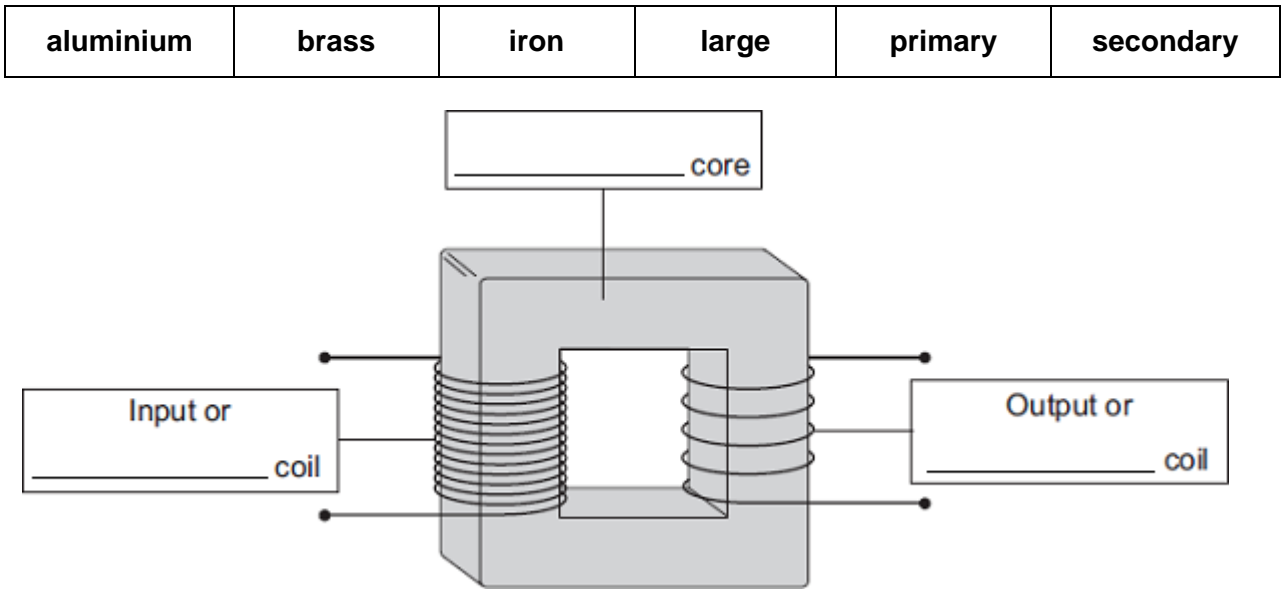

(3)

(b) Batteries inside laptop computers are charged using laptop chargers. The laptop charger contains a traditional transformer.

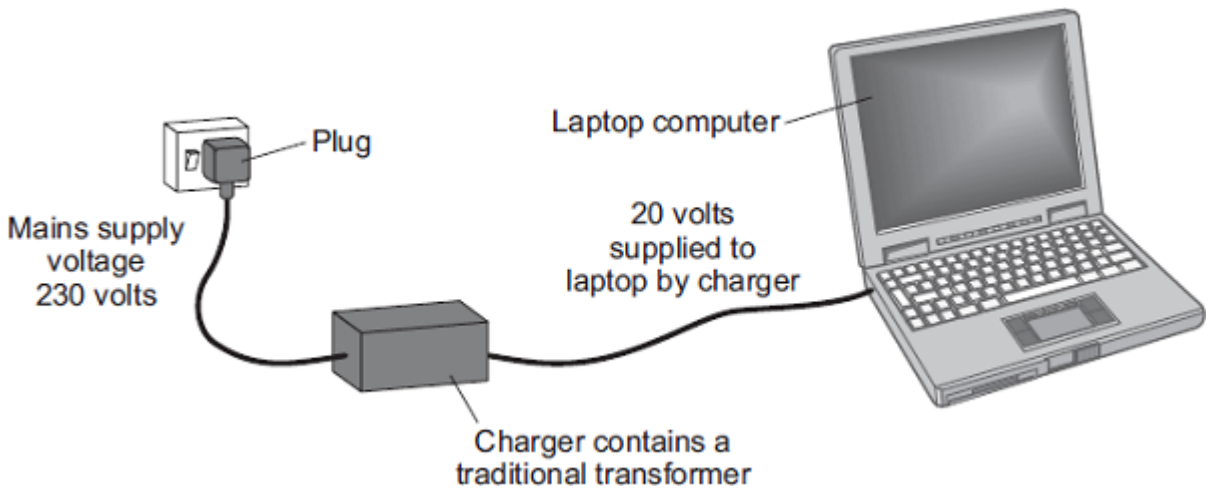

The laptop charger contains a step-down transformer.

What does a step-down transformer do?

---

---

(1)

- (c) Laptop batteries and mobile phone batteries can only be recharged a limited number of times. When a battery cannot be recharged, it is better to recycle the battery than to throw it away.

Draw a ring around the correct answer to complete the sentence.

The batteries are recycled mainly due to

an environmental

a political

a social

consideration.

(1)

(Total 5 marks)



13

Batteries inside laptop computers are charged using laptop chargers. The laptop charger contains a traditional transformer.

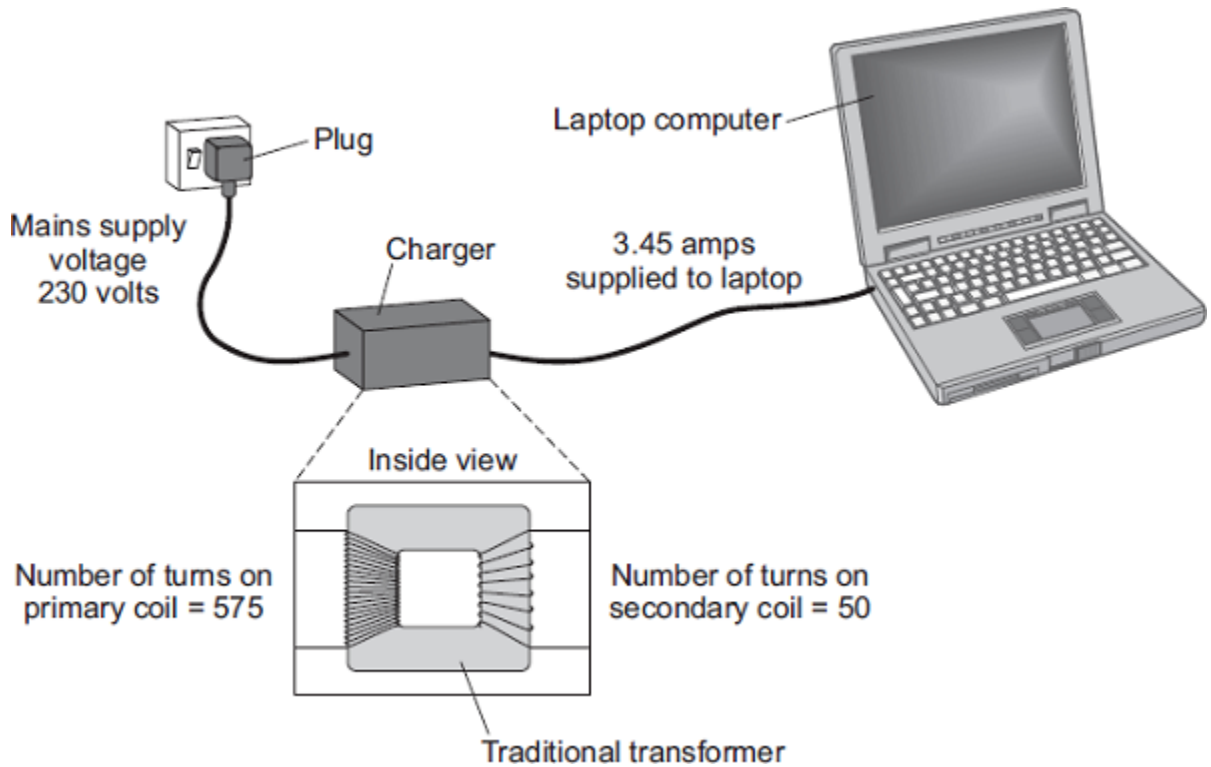

- (a) The alternating current flowing through the primary coil of the transformer creates an alternating current in the secondary coil.

Explain how.

---

---

---

---

---

---

---

---

---

---

(3)

- (b) (i) Use information from the diagram to calculate the potential difference the charger supplies to the laptop.

---

---

---

---

Potential difference = \_\_\_\_\_ V

(2)

- (ii) Calculate the current in the primary coil of the transformer when the laptop is being charged.

Assume the transformer is 100% efficient.

---

---

---

---

Current = \_\_\_\_\_ A

(2)

- (c) Laptop batteries and mobile phone batteries can only be recharged a limited number of times. After this, the batteries cannot store enough charge to be useful. Scientists are developing new batteries that can be recharged many more times than existing batteries.

Suggest **one** other advantage of developing these new batteries.

---

---

---

(1)

(Total 8 marks)

14

(a) In the National Grid, very large step-up transformers link power stations to the transmission cables.

A transformer used for this purpose has 800 turns on its primary coil and 12 800 turns on its secondary coil. The p.d. (potential difference) across its primary coil is 25 kV.

Use the equation in the box to calculate the p.d. across its secondary coil.

$$\frac{\text{p.d. across primary}}{\text{p.d. across secondary}} = \frac{\text{number of turns on primary}}{\text{number of turns on secondary}}$$

Show clearly how you work out your answer.

---

---

p.d. across secondary coil = \_\_\_\_\_ volts

(2)

(b) The diagram shows the structure of a transformer.

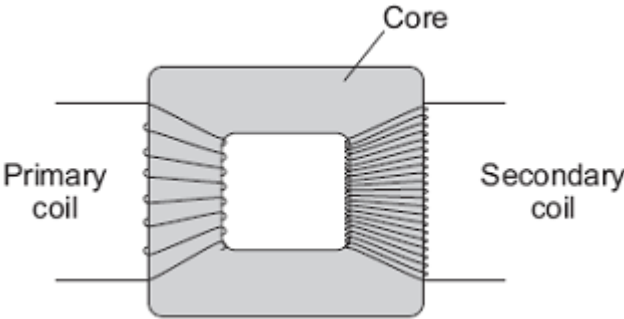

(i) The primary and secondary coils of a transformer are made of insulated wire.  
Why is this insulation necessary?

---

---

(1)

(ii) Why is the core made of iron?

---

---

(1)

(iii) Explain how the transformer works.

---

---

---

---

---

---

---

(3)

(c) Before 1926, large towns had their own local power stations. After 1926, these power stations were connected to form the National Grid.

Give **two** advantages of having a National Grid system.

1. \_\_\_\_\_

\_\_\_\_\_

2. \_\_\_\_\_

\_\_\_\_\_

(2)

(Total 9 marks)

15

The diagram shows a student's design for a simple wind speed gauge.

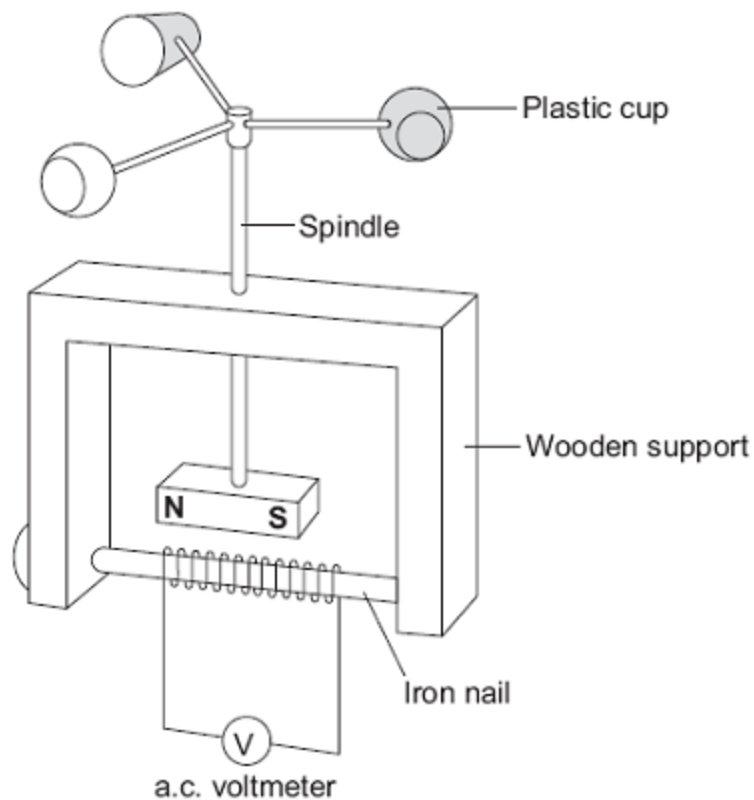

- (a) Explain why the wind causes the a.c. voltmeter to give a reading. The explanation has been started for you.

*The wind causes the plastic cups to turn.* \_\_\_\_\_

---



---



---



---



---



---

(3)

- (b) The gauge is not sensitive enough to measure light winds.

Suggest **one** way that the design can be modified to make the gauge more sensitive.

---



---

(1)

(Total 4 marks)

16

The diagram shows the apparatus used by a student to investigate a transformer.

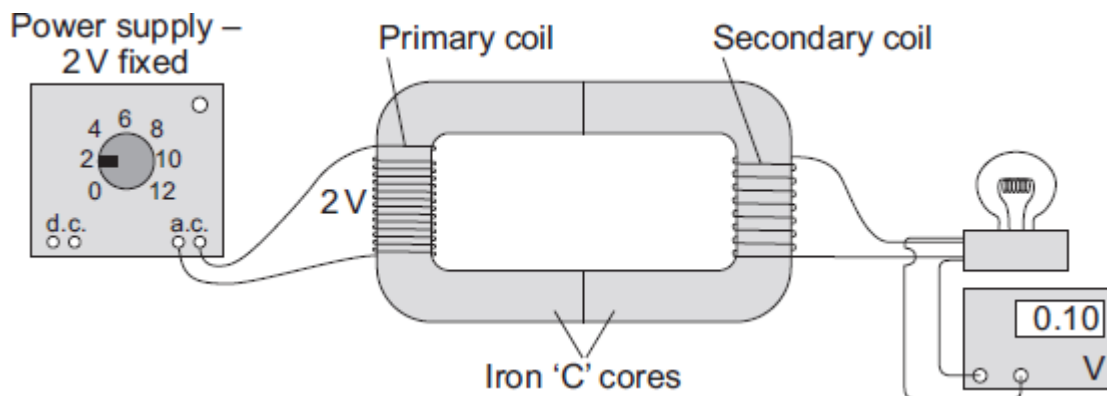

- (a) The transformer made by the student would not have worked if the core had been made from aluminium and not iron.

Why?

---



---

(1)

- (b) The student made changes to the number of turns used to make the secondary coil. He then measured the potential difference across the secondary coil after each change. The graph shows the student's results.

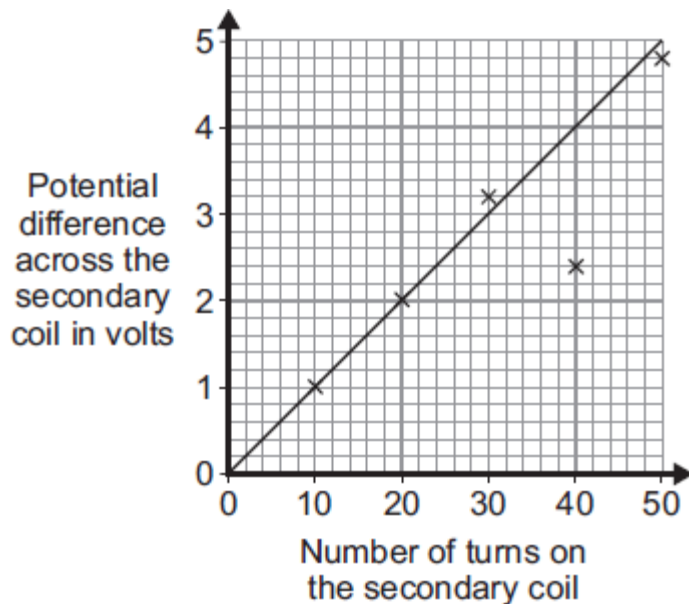

- (i) What range of values was used for the number of turns on the secondary coil?

From \_\_\_\_\_ to \_\_\_\_\_

(1)

- (ii) When he drew the line of best fit, the student ignored one of the data points.

Why?

\_\_\_\_\_

\_\_\_\_\_

(1)

- (iii) What is the minimum number of turns needed on the secondary coil for the transformer to act as a step-up transformer?

\_\_\_\_\_

Give a reason for your answer.

\_\_\_\_\_

\_\_\_\_\_

(2)

- (c) A radio can be used with a 9 V battery or it can be plugged into the 230 V mains electricity supply using an adapter. The mains adapter contains a transformer.

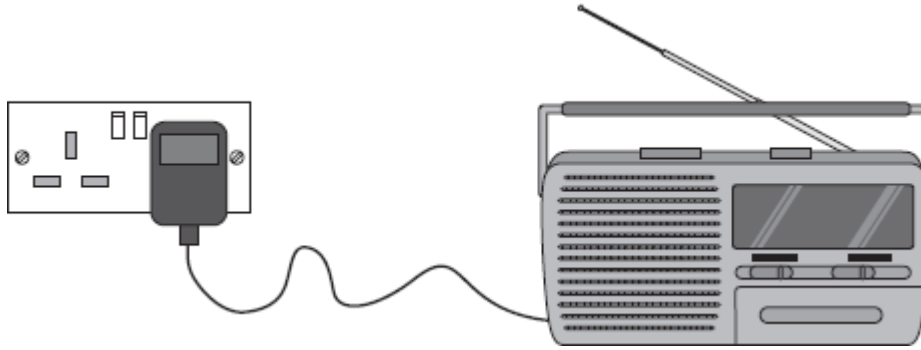

Why must the mains adapter contain a transformer?

---

---

(1)  
(Total 6 marks)

17

The diagram shows a transformer.

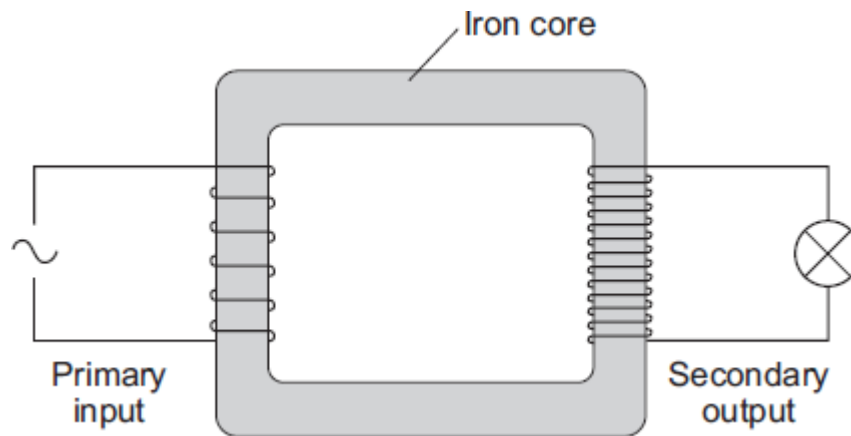

- (a) (i) Is the transformer in the diagram being used as a step-up transformer or as a step-down transformer?

Put a tick (✓) in the box next to your answer.

a step-up transformer

a step-down transformer

Give a reason for your answer.

---

---

(1)

- (ii) Why is the core made of iron?

---

---

(1)

- (b) The power supply to a laptop computer contains a transformer designed to change the 230 V mains input to a 15 V output. The transformer has 920 turns on its primary coil.

Use the equation in the box to calculate the number of turns on the secondary coil.

$$\frac{\text{p.d. across primary}}{\text{p.d. across secondary}} = \frac{\text{number of turns on primary}}{\text{number of turns on secondary}}$$

Show clearly how you work out your answer.

---

---

---

Number of turns on the secondary coil = \_\_\_\_\_

(2)

(Total 4 marks)



18

The diagram shows part of the system used to supply a farm with electricity.

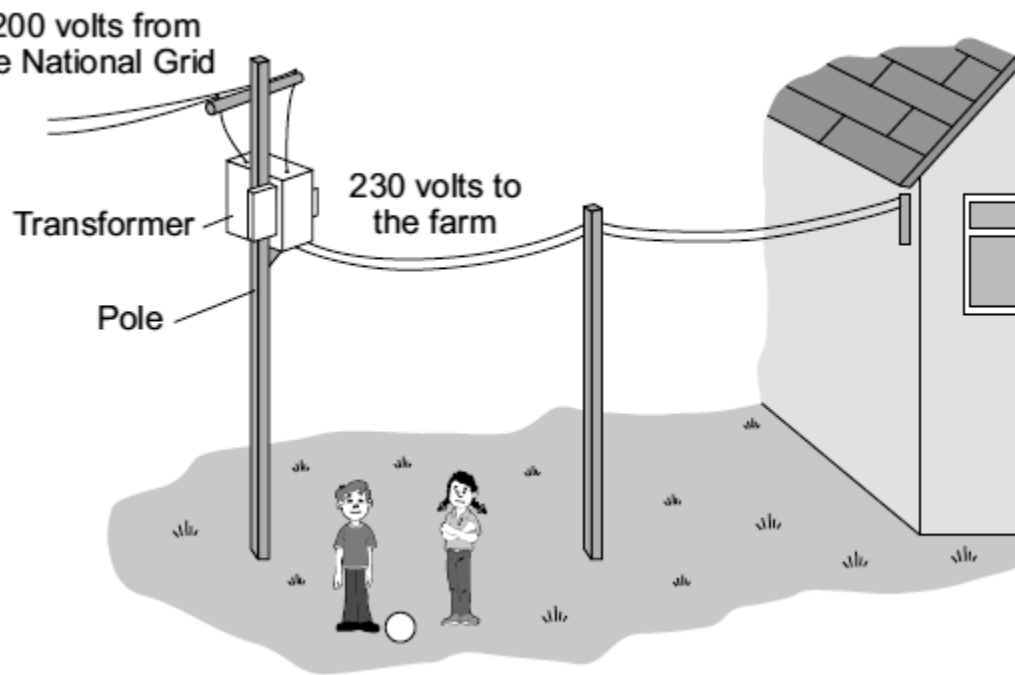

(a) The core of the transformer is made of metal.

Complete the following sentence by drawing a ring around the correct word in the box.

The metal used for the core of the transformer is

- copper.
- iron.
- steel.

(1)

(b) (i) What sort of transformer is shown in the diagram?

\_\_\_\_\_

(1)

(ii) Complete the following sentence by drawing a ring around the correct line in the box.

In this transformer, the number of turns on the secondary coil is

- less than
- the same as
- greater than

the number of turns on the primary coil.

(1)

- (c) Transformers and other electrical equipment can be dangerous.

The following bar chart shows the numbers of children, aged 14 or under, killed or injured in electrical accidents in the UK in 2000, 2001 and 2002.

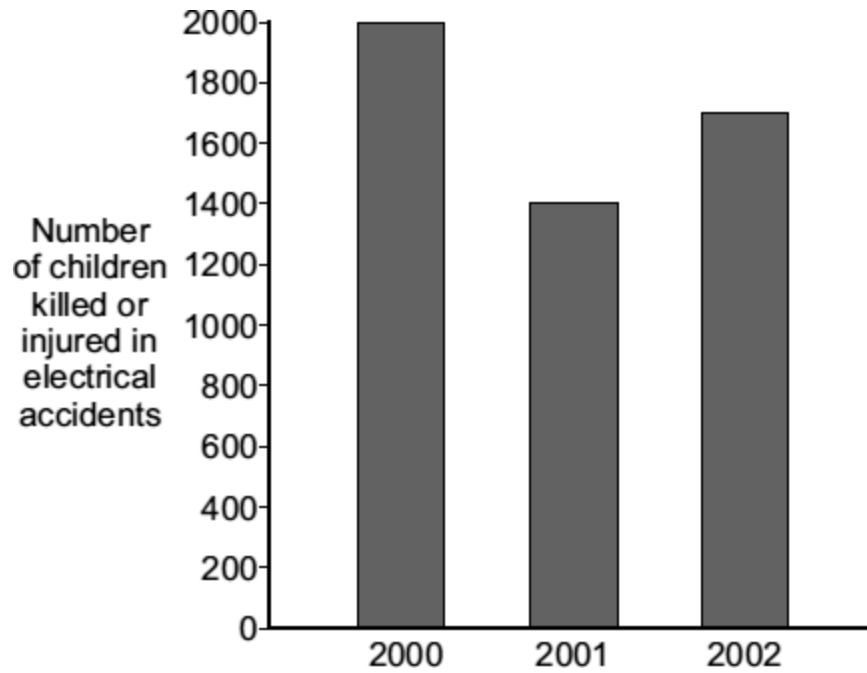

- (i) In which of these years were most children killed or injured in electrical accidents?

---

(1)

- (ii) A newspaper claims that the number of children killed or injured by electrical accidents will increase in 2011.

Which of the following gives a reason why the information given in the graph does not support this claim.

Put a tick (✓) in the box next to your answer.

The pattern shows an upward trend.

The pattern shows a downward trend.

There is no pattern.

(1)

(Total 5 marks)

19

(a) The drawing shows the plug for operating a radio from the mains.

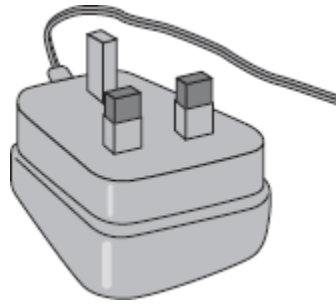

This plug contains a transformer. There are 4600 turns on its primary coil and 200 turns on its secondary coil. The plug is used on the mains supply and has a potential difference (p.d.) of 230 V across its primary coil.

Use the equation in the box to calculate the p.d. across the secondary coil of the transformer.

$$\frac{\text{p.d. across primary}}{\text{p.d. across secondary}} = \frac{\text{number of turns on primary}}{\text{number of turns on secondary}}$$

Show clearly how you work out your answer.

---

---

---

---

p.d. across secondary = \_\_\_\_\_ V

(2)

(b) The coils of the transformer are made of insulated wire.

Why is the wire insulated?

---

---

(1)

(c) (i) What material is the core of a transformer made from?

---

(1)

(ii) Why is the core made from this material?

---

---

(1)

(Total 5 marks)

20

(a) In the National Grid, very large step-up transformers link power stations to the transmission cables.

A transformer used for this purpose has 800 turns on its primary coil and 12 800 turns on its secondary coil. The p.d. (potential difference) across its primary coil is 25 kV.

Use the equation in the box to calculate the p.d. across its secondary coil.

$$\frac{\text{p.d. across primary}}{\text{p.d. across secondary}} = \frac{\text{number of turns on primary}}{\text{number of turns on secondary}}$$

Show clearly how you work out your answer **and** give the unit.

---

---

p.d. across secondary coil = \_\_\_\_\_

(3)

(b) The primary and secondary coils of a transformer are made of insulated wire.

Why is this insulation necessary?

---

---

(1)

(c) Describe what happens when an alternating potential difference is applied across the primary coil of a transformer.

---

---

---

---

---

---

(3)

(Total 7 marks)

21

(a) The diagram shows the basic structure of a step-up transformer.

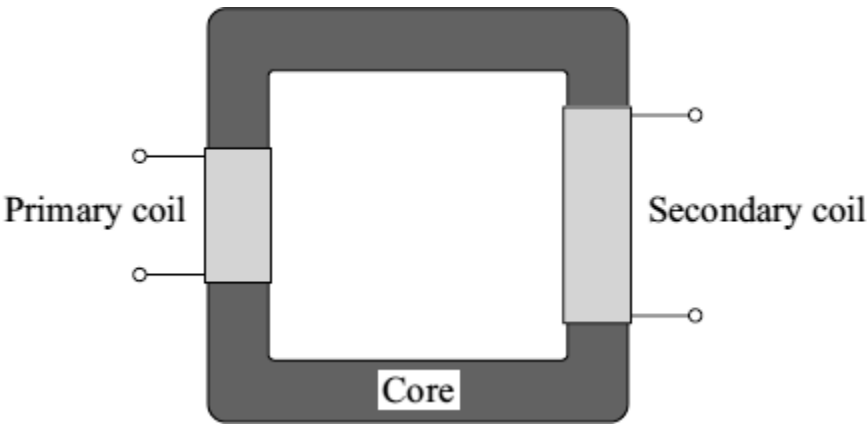

(i) What is the core made of?

---

(1)

(ii) Explain how an alternating input produces an alternating output.

---

---

---

---

---

---

---

(3)

- (b) Fly killers are used in kitchens and food stores because flying insects carry diseases which cause food poisoning.

The diagram shows the inside of one design. Insects are attracted to a fluorescent lamp. The metal grids have a high potential difference (p.d.) between them. The insects are killed as they fly between the grids.

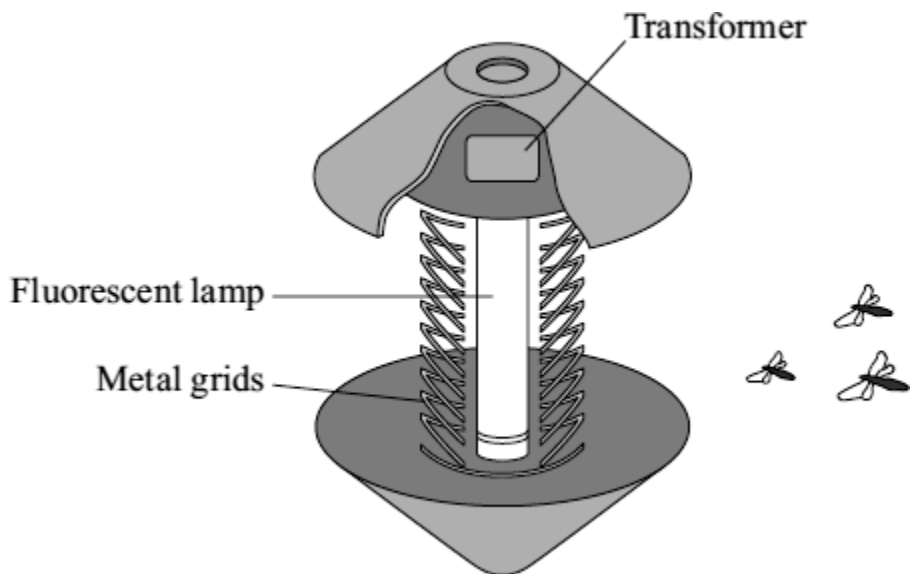

A transformer is used in the fly killer. There is a p.d. of 230 V across the primary coil. There are 300 turns of wire on the primary coil and 4000 turns on the secondary coil.

Use the equation in the box to calculate the p.d. across the secondary coil.

$$\frac{\text{p.d. across primary}}{\text{p.d. across secondary}} = \frac{\text{number of turns on primary}}{\text{number of turns on secondary}}$$

Show clearly how you work out your answer.

---

---

---

---

---

Potential difference = \_\_\_\_\_ V

(3)

(Total 7 marks)

A teacher demonstrates a small transformer.

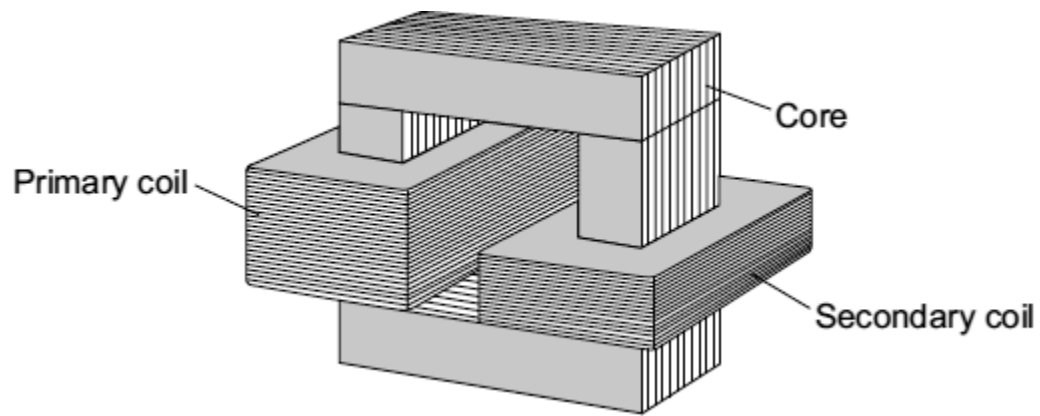

- (a) (i) What is the core made of?

Draw a ring around the correct word in the box.

|           |        |      |
|-----------|--------|------|
| aluminium | copper | iron |
|-----------|--------|------|

(1)

- (ii) The potential difference (p.d.) across the secondary coil is less than the p.d. across the primary coil.

What sort of transformer is it?

---

(1)

- (b) Where is a step-up transformer used as part of the National Grid?

---

(1)

(c) The teacher writes a note about the transformer but leaves **five** spaces.

Use the correct words from the box to complete the spaces.

|             |             |                |             |              |             |
|-------------|-------------|----------------|-------------|--------------|-------------|
| <b>coil</b> | <b>core</b> | <b>current</b> | <b>ends</b> | <b>field</b> | <b>wire</b> |
|-------------|-------------|----------------|-------------|--------------|-------------|

A transformer works because an alternating \_\_\_\_\_ in the primary \_\_\_\_\_ produces a changing magnetic \_\_\_\_\_ in the \_\_\_\_\_ and then in the secondary coil.

This induces an alternating potential difference across the \_\_\_\_\_ of the secondary coil.

(5)  
(Total 8 marks)

23

The diagram shows a USB power adapter which plugs into a 230 V a.c. mains socket.



The adapter contains a small step-down transformer.

(a) The core of the transformer is made of laminated soft iron.

Why is iron used?

---

---

(1)

(b) The coils of the transformers are made of insulated copper wire.

Why is the wire insulated?

---

---

(1)



- (c) There are 500 turns on one coil of the transformer and 20 000 turns on the other coil.

Use the equation in the box to calculate the p.d. across the secondary coil.

$$\frac{\text{p.d. across primary}}{\text{p.d. across secondary}} = \frac{\text{number of turns on primary}}{\text{number of turns on secondary}}$$

Show clearly how you work out your answer and give the unit.

---

---

---

p.d. across the secondary = \_\_\_\_\_

(3)

(Total 5 marks)

24

- (a) The basic structure of a transformer is a primary coil of insulated wire, an iron core and a secondary coil of insulated wire.

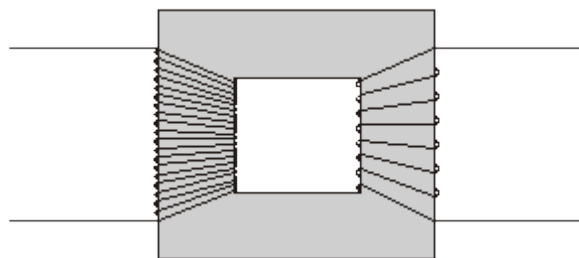

- (i) Why is the core made of iron?

---

---

(1)

(ii) Explain how a transformer works.

---

---

---

---

---

---

---

---

---

(4)

(b) A small step-down transformer is used in the charger for an electric screwdriver.

The input to the transformer is 230 V a.c. mains supply and the output is 5.75 V a.c. There are 3200 turns on the primary coil.

Use the equation in the box to calculate the number of turns on the transformer's secondary coil.

$$\frac{\text{p.d. across primary}}{\text{p.d. across secondary}} = \frac{\text{number of turns on primary}}{\text{number of turns on secondary}}$$

Show clearly how you work out your answer.

---

---

Number of turns = \_\_\_\_\_

(2)

(Total 7 marks)

(a) The diagram shows a transformer.

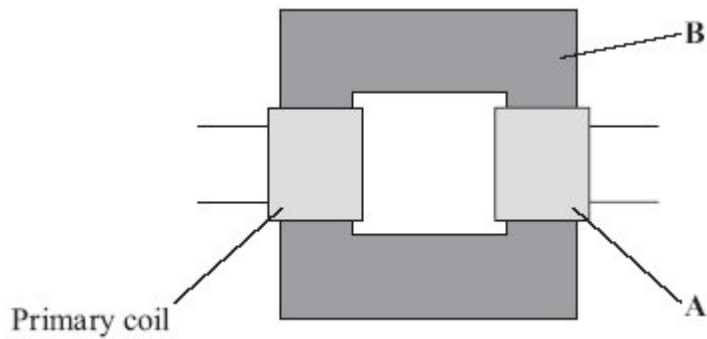

(i) What is part **A**?

\_\_\_\_\_

(1)

(ii) What is part **B** and what is it made of?

\_\_\_\_\_  
\_\_\_\_\_

(2)

(iii) When there is an alternating current in the primary coil, what is produced in part **B**?

\_\_\_\_\_  
\_\_\_\_\_

(2)

(b) Transformers are used in the National Grid. The diagram shows part of the National Grid.

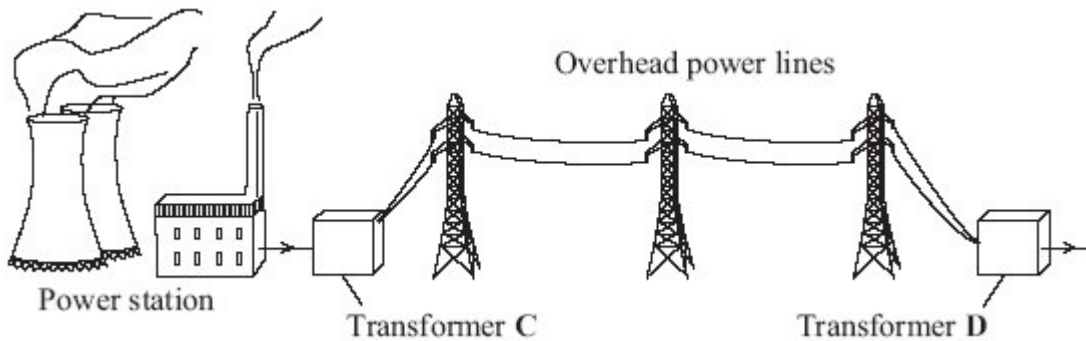

Complete the **two** spaces in the sentence.

Transformer **C** is a \_\_\_\_\_ transformer and transformer **D** is  
a \_\_\_\_\_ transformer.

(1)

(c) This is an item from a newspaper.

**Health at risk from power lines?**  
Are high voltage power lines a health risk to people who live near them?  
Some scientists think that scientific evidence shows that they are.  
Other scientists do not think that the scientific evidence supports this conclusion.

Which **two** suggestions would reduce the possible risk to people's health?  
Put a tick (✓) in the box next to your answers.

- Do not build new houses near to existing power lines.
- Move the power lines so that they take the shortest routes.
- Move each power station to the centre of the nearest city.
- Build new power lines away from where people live.
- Use more transformers in the National Grid.

(2)  
(Total 8 marks)

26

(a) The diagram shows a transformer.

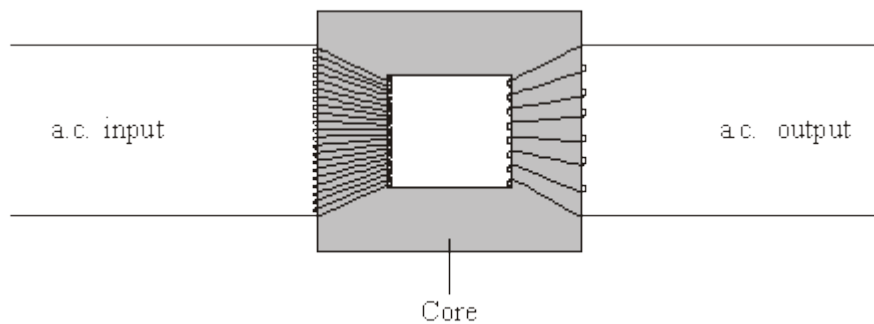

- (i) Is the transformer in the diagram being used as a step-up transformer or as a step-down transformer?

Put a tick (✓) in the box next to your answer.

a step-up transformer

a step-down transformer

Explain your answer.

---

---

(1)

- (ii) Why is insulated wire, and not uninsulated wire, used to make the coils?

---

---

(1)

- (iii) Why is the core made of iron?

---

---

(1)

- (b) A transformer has 500 turns on its primary coil and 7500 turns on its secondary coil. The potential difference across the primary coil is 150 volts.

Use the equation in the box to calculate the potential difference across the secondary coil.

$$\frac{\text{p.d. across primary}}{\text{p.d. across secondary}} = \frac{\text{number of turns on primary}}{\text{number of turns on secondary}}$$

Show clearly how you work out your answer.

---

---

---

Potential difference across the secondary coil = \_\_\_\_\_ volts

(2)

(c) Step-down transformers are used between power lines and people's houses.

Explain why.

---

---

---

**(2)**

(d) Before 1926, large towns had their own local power stations. After 1926, these power stations were connected to form the National Grid.

Explain the advantage of having a National Grid system.

---

---

---

---

**(2)**

**(Total 9 marks)**

27

The diagram shows the design for a remotely controlled door bolt.

When the correct numbers are entered into the keypad the transformer switches on. Then the door can be opened.

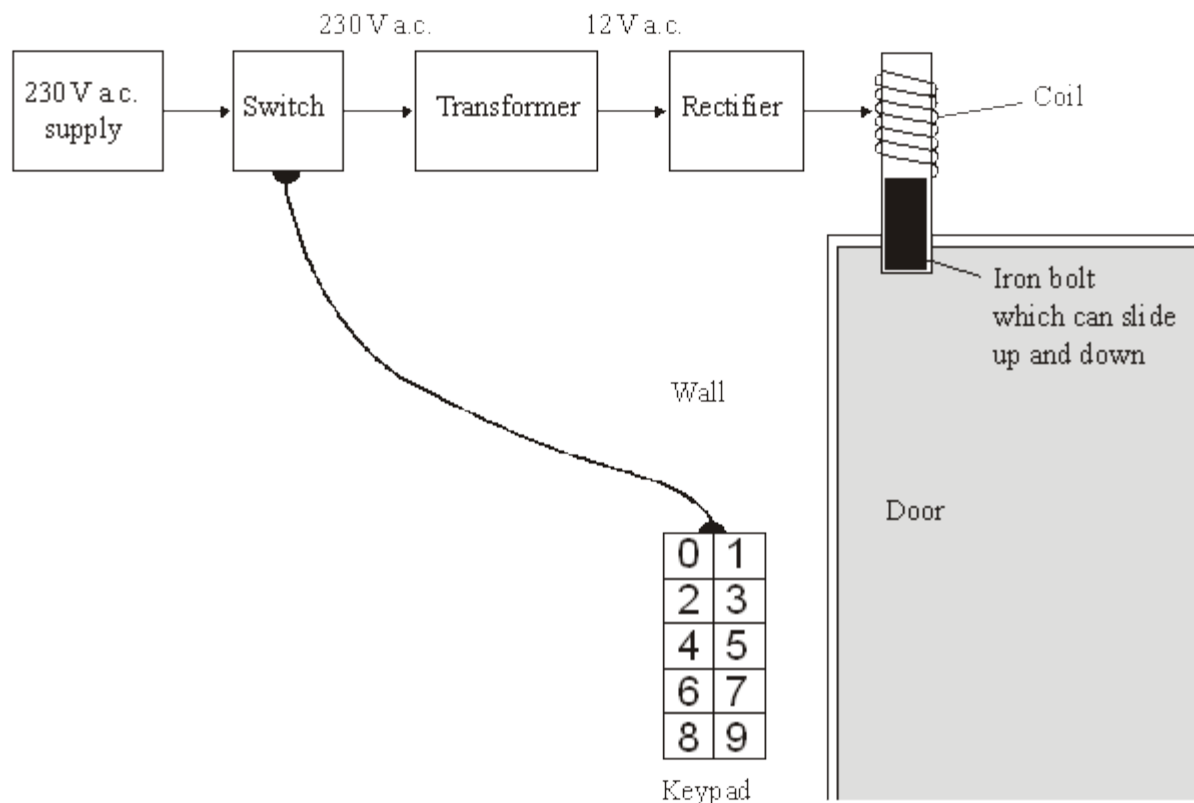

(a) What kind of transformer is shown in the diagram?

\_\_\_\_\_

(1)

(b) What does the abbreviation a.c. stand for?

\_\_\_\_\_

(1)

(c) Complete the sentences using the correct words from the box.

|          |           |             |          |        |
|----------|-----------|-------------|----------|--------|
| attracts | downwards | magnet      | reflects | repels |
| sideways | switch    | transformer | upwards  |        |

(i) When a current flows in the coil, the coil becomes a \_\_\_\_\_.

(ii) The coil \_\_\_\_\_ the iron bolt which moves \_\_\_\_\_

(3)

(Total 5 marks)

28

(a) This notice is on the back of a television set.



The transformer used in the television set has 75 turns on its primary coil. The potential difference (p.d.) across the primary coil is 230 volts and the p.d. across the secondary coil is 32 200 volts.

Use the equation below to calculate the number of turns on the secondary coil.

$$\frac{\text{p.d. across primary}}{\text{p.d. across secondary}} = \frac{\text{number of turns on primary}}{\text{number of turns on secondary}}$$

Show clearly how you work out your answer.

---

---

---

Number of turns on the secondary coil = \_\_\_\_\_

(2)



(b) The diagram shows the structure of a transformer.

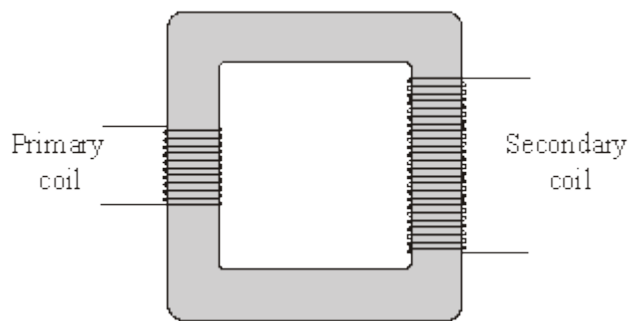

Explain how the transformer works.

---



---



---



---



---



---

(3)

(Total 5 marks)

29

A transformer is used to reduce the 230 V a.c. mains to the 12 V supply required for the lighting system. The transformer has 1150 turns on its primary coil.

Calculate the number of turns on the secondary coil of the transformer. Show clearly how you work out your answer.

---



---



---

number of turns on the secondary coil = \_\_\_\_\_

(2)

(Total 2 marks)

30

(a) The diagram represents a simple transformer used to light a 12 V lamp. When the power supply is switched on the lamp is very dim.

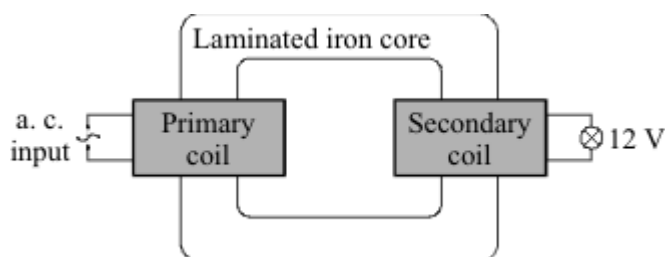

(i) Give **one** way to increase the voltage at the lamp without changing the power supply.

---

---

(1)

(ii) What is meant by the iron core being *laminated*?

---

---

(1)

(b) Electrical energy is distributed around the country by a network of high voltage cables.

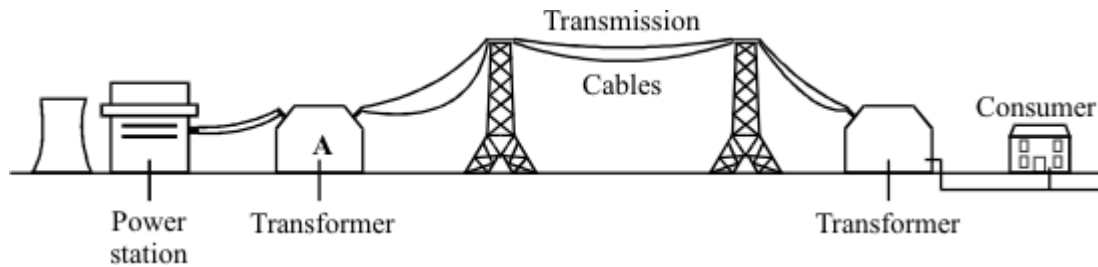

(i) For the system to work the power is generated and distributed using alternating current rather than direct current. Why?

---

---

(1)

(ii) Transformers are an essential part of the distribution system. Explain why.

---

---

---

(2)

(iii) The transmission cables are suspended high above the ground. Why?

---

(1)

(c) The power station generates 100 MW of power at a voltage of 25 kV. Transformer **A**, which links the power station to the transmission cables, has 44 000 turns in its 275 kV secondary coil.

(i) Write down the equation which links the number of turns in each transformer coil to the voltage across each transformer coil.

---



---

(1)

(ii) Calculate the number of turns in the primary coil of transformer **A**. Show clearly how you work out your answer.

---



---



---

Number of turns = \_\_\_\_\_

(2)

(d) The diagram shows how the cost of transmitting the electricity along the cables depends upon the thickness of the cable.

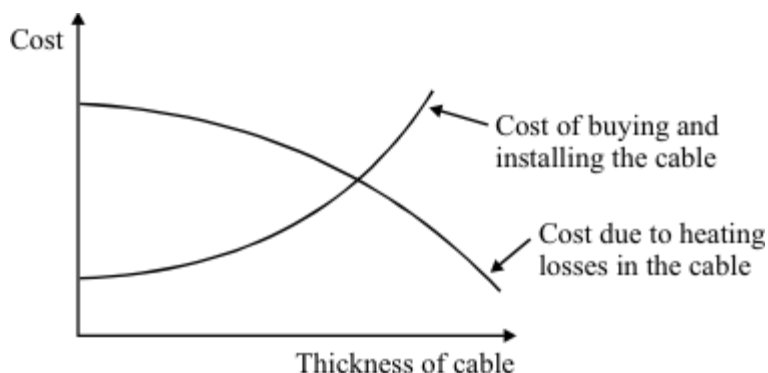

(i) Why does the cost due to the heating losses go down as the cable is made thicker?

---

(1)

(ii) By what process is most heat energy lost from the cables?

---

(1)

**(Total 11 marks)**

31

The diagram below shows a transformer.

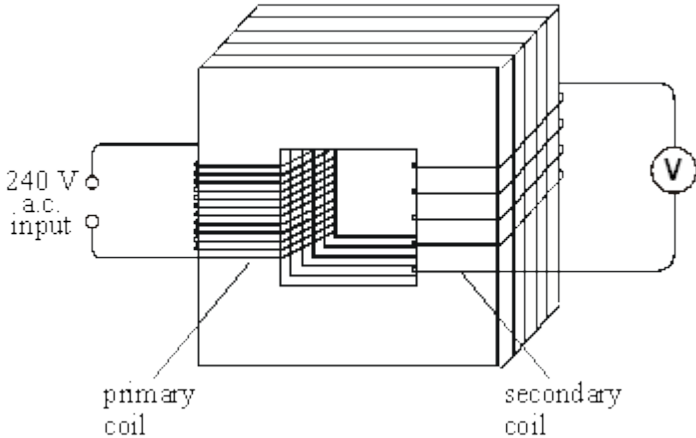

(i) Name the material used to make the core of the transformer.

\_\_\_\_\_

(1)

(ii) The primary coil has 48 000 turns and the secondary coil 4000 turns.

If the input voltage is 240 V a.c., calculate the output voltage.

\_\_\_\_\_

\_\_\_\_\_

Answer \_\_\_\_\_ V

(2)

(iii) Explain how the use of such a transformer could be adapted to transform a low voltage into a higher voltage.

\_\_\_\_\_

\_\_\_\_\_

(1)

(Total 4 marks)

32

(a) An appliance in a house has a transformer. The transformer is used to reduce the voltage to the level needed by the appliance.

The diagram shows the transformer.

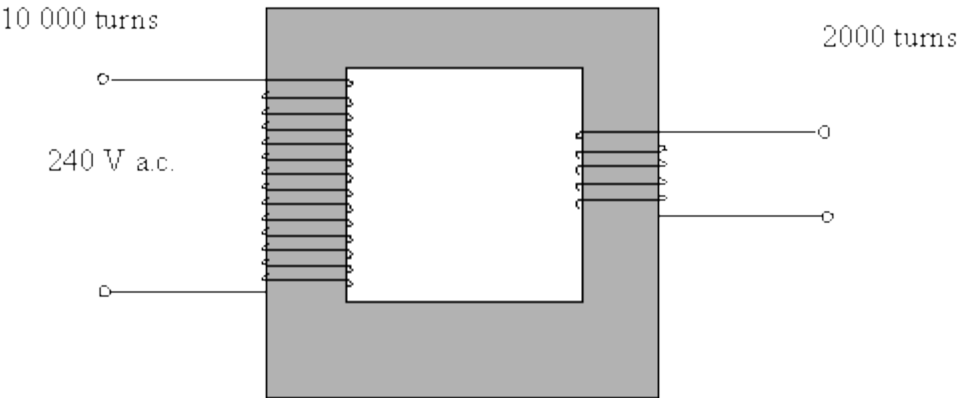

(i) Name the material used for the core of the transformer.

\_\_\_\_\_

(1)

(ii) The transformer has 10 000 turns on the input side and 2000 turns on the output side. If the mains voltage of 240 volts is applied to the input, calculate the output voltage. You may find the following information helpful:

$$\frac{\text{output voltage}}{\text{input voltage}} = \frac{\text{number of turns on output coil}}{\text{number of turns on input coil}}$$

\_\_\_\_\_  
\_\_\_\_\_  
\_\_\_\_\_  
\_\_\_\_\_

(3)

(b) Explain, in terms of magnetic fields, how a transformer works.

\_\_\_\_\_  
\_\_\_\_\_  
\_\_\_\_\_  
\_\_\_\_\_  
\_\_\_\_\_

(4)

- (c) A 12 V car battery is connected to the input leads of the transformer. It is hoped to reduce the voltage to 2.4 V in order to run a small motor. When the output voltage is measured it is found to be zero.

Explain why the output voltage is zero.

---

---

---

---

(2)

(Total 10 marks)

33

- (a) The drawing shows a small transformer used to recharge the battery in a 4.2 V mobile phone from a 230 V mains supply.

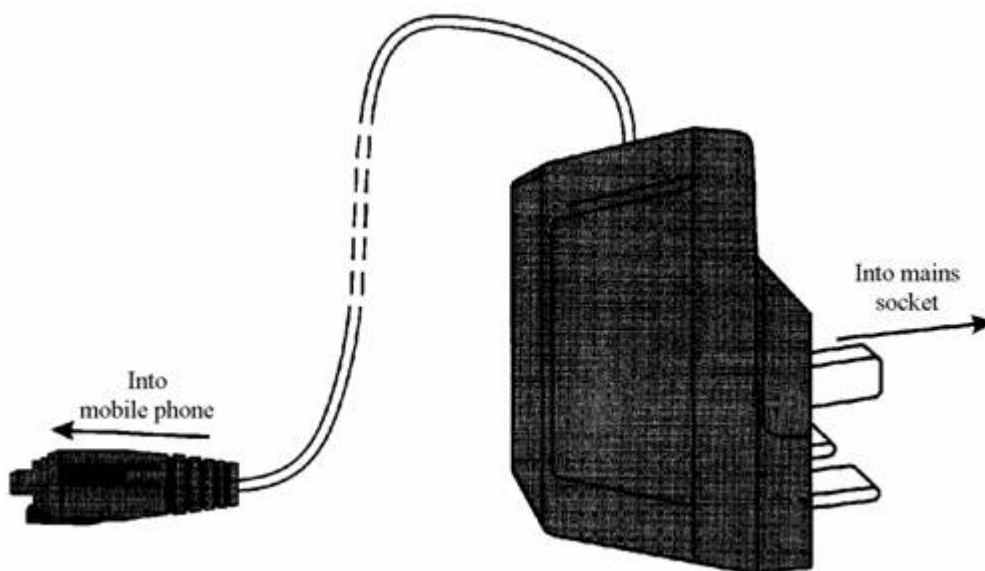

Explain how you know that this is a *step-down* transformer.

---

---

(1)

- (b) A transformer consists of an insulated coil of wire, called the primary coil, on one side of a core. Another coil of insulated wire, called the secondary coil, is on the other side.

Give **two** features of the *core*.

1. \_\_\_\_\_
2. \_\_\_\_\_

(2)

(Total 3 marks)