

Answer ALL questions. Write your answers in the spaces provided.

Some questions must be answered with a cross in a box ☒. If you change your mind about an answer, put a line through the box ☒ and then mark your new answer with a cross ☒.

1 Computational thinking

(a) Identify the term that means breaking a problem or solution down into smaller parts.

(1)

- A Abstraction
- B Computation
- C Decomposition
- D Evaluation

(b) State **two benefits** of subprograms.

(2)

1

2

DO NOT WRITE IN THIS AREA

DO NOT WRITE IN THIS AREA

DO NOT WRITE IN THIS AREA



(c) Here is an algorithm that uses colours.

```
1 # -----
2 # Global variables
3 # -----
4 theColours = ["Green", "Blue", "Yellow", "Red", "Purple"]
5 colour = ""
6
7 # -----
8 # Main program
9 # -----
10
11 for item in theColours:
12     print (item)
13
14 colour = input ("Enter a colour: ")
15 while (colour != ""):
16     if (colour == "Green"):
17         print ("Green is my favourite colour")
18     else:
19         print (colour + " is a good colour")
20
21     colour = input ("Enter a colour: ")
```

(i) Give the first line number of a condition-controlled loop.

(1)

(ii) Give the first line number of iteration over every item in a data structure.

(1)

(iii) Give the line numbers of a selection.

(1)



(d) Programs can have syntax errors and runtime errors.

(i) Define the term 'syntax error'.

(1)

.....

.....

(ii) Runtime errors happen when a program is executing.

Explain a runtime error.

(2)

.....

.....

.....

.....

.....

.....

(e) Algorithms use relational and arithmetic operators.

(i) Here is a relational operator used in a conditional test.

```
count > index
```

State the **two** different results of evaluating a conditional test.

(2)

1

2

(ii) Identify the result of `5 // 2`

(1)

- A** 0.5
- B** 1
- C** 2
- D** 2.5



(f) Programmers consider algorithm efficiency when they write code.

(i) Sorting and searching use algorithms.

Complete the table with the name of a search algorithm and a sort algorithm.

(2)

Algorithm type	Characteristic	Algorithm name
Search	Is a divide and conquer algorithm	
Sort	Is not a divide and conquer algorithm	

(ii) Explain **one** effect the number of comparisons has on the execution time of a sorting algorithm.

(2)

.....

.....

.....

.....

(Total for Question 1 = 16 marks)

DO NOT WRITE IN THIS AREA

DO NOT WRITE IN THIS AREA

DO NOT WRITE IN THIS AREA



P 7 8 2 0 0 R A 0 5 2 0

2 Data

(a) The ASCII system is used to represent letters and symbols.

(i) State the number of bits used to represent each letter or symbol in ASCII. (1)

(ii) The ASCII code 65 represents the letter A.

Give the letter represented by the ASCII code 68. (1)

(b) Sound waves are converted to binary using sample intervals.

Define the term 'sample interval'. (1)

(c) Give an expression to calculate the size of a bitmap image, not the size of the file that stores the image.

(2)



(d) Computers manipulate binary patterns.

(i) Complete the table with the result of applying the shift to the binary pattern. (2)

Binary pattern	Shift	8-bit binary result
1010 0011	Logical shift left by 3	
1100 1010	Arithmetic shift right by 2	

(ii) Identify the correct statement about overflow. (1)

- A Causing the program to crash during an arithmetic operation
- B Requiring more bits to store a result than are available to store it
- C Switching between binary and hexadecimal number systems
- D Using an index less than 0 or greater than the length of an array

(iii) Convert the denary value +112 to 8-bit binary representation. (2)

.....

.....

.....

.....

(iv) Give the 8-bit binary two's complement representation of denary -73 (2)

.....

.....

.....

.....



(e) The number of bits determines the number of patterns that can be represented.

(i) Identify the number of symbols available in the hexadecimal system. (1)

- A 2
- B 8
- C 10
- D 16

(ii) The address bus of a computer is 8-bits wide.
State the number of unique addresses that can be accessed. (1)

(f) Construct an expression to convert 40 681 930 227 712 bytes to tebibytes. (2)

.....

.....

.....

.....

.....

(Total for Question 2 = 16 marks)



DO NOT WRITE IN THIS AREA

DO NOT WRITE IN THIS AREA

DO NOT WRITE IN THIS AREA

BLANK PAGE



P 7 8 2 0 0 R A 0 9 2 0

3 Networks

(a) Networks are described in many different ways.

(i) Give the type of network that covers a small geographical area. (1)

.....

(ii) Name the characteristic of a wireless network that is measured in metres. (1)

.....

(iii) Give **two disadvantages** of a bus network topology. (2)

1

.....

2

.....

(b) Describe penetration testing. (2)

.....

.....

.....

.....



DO NOT WRITE IN THIS AREA

(c) Network protocols control the rules of communication.

(i) Name a network protocol that transmissions from other electrical devices can interfere with and that can be blocked by walls. (1)

(ii) Name the network protocol used to download a music file from a server. (1)

(d) Describe how the link layer of the TCP/IP protocol stack works. (2)

(e) Construct an expression to calculate the transmission rate, in megabits per second, required to transmit a 1.4 gibibyte file in 13 minutes. (4)

You do not need to do the calculation.

(Total for Question 3 = 14 marks)



P 7 8 2 0 0 R A 0 1 1 2 0

4 Computers

(a) A compiler translates source code to machine code. If the source code is edited, it must be recompiled.

Give **two other** characteristics of a compiler.

(2)

1

.....

2

.....

(b) Describe how an operating system organises files and folders.

(2)

.....

.....

.....

.....

.....

.....

(c) Explain **one** way an audit trail helps programmers create robust software.

(2)

.....

.....

.....

.....

.....



DO NOT WRITE IN THIS AREA

DO NOT WRITE IN THIS AREA

DO NOT WRITE IN THIS AREA

(d) Parking at an airport is controlled by computers.

No paper tickets are issued.

Here is an image of the control system at the exit.



The control system uses sensors, a camera and a database.

The barrier lifts if the parking fee has been paid.

Describe what the system does when the exit sensor is activated by a car driving towards it.

(2)

.....

.....

.....

.....



(e) The components of a computer carry out the fetch-decode-execute cycle.

Complete the diagram with:

- the names of **two** buses
- a directional connection from the clock to the correct component.

(3)

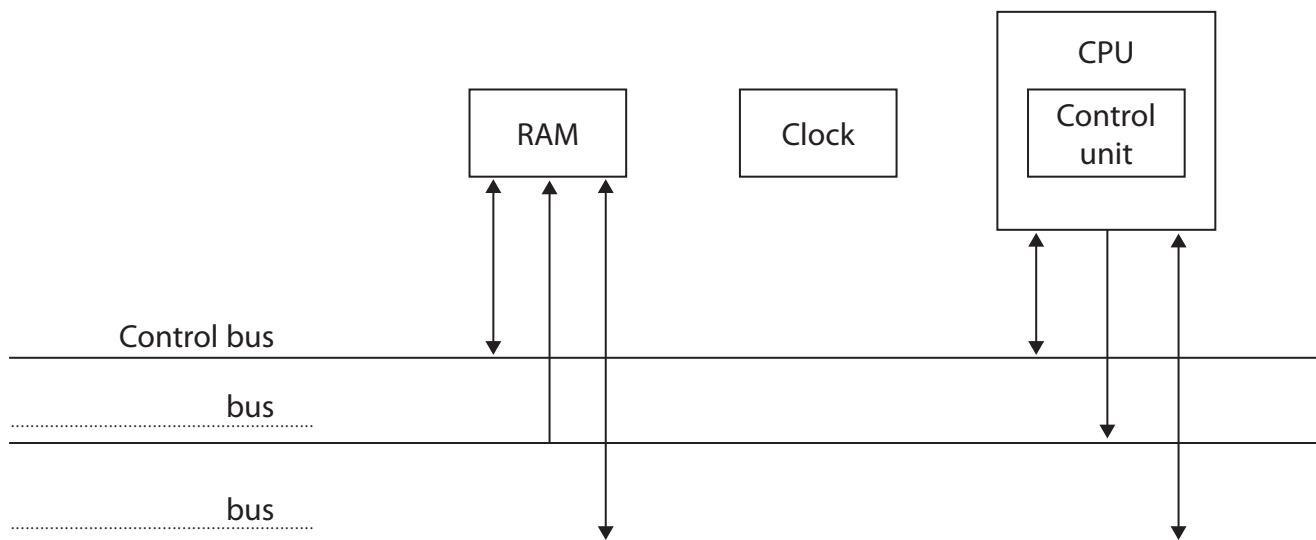

DO NOT WRITE IN THIS AREA

(f) A company is developing a new smartphone.

The smartphone has built-in devices, including a camera and a sound recorder.

The smartphone has applications, including one to edit pictures, one to translate speech to a text file and one for email.

Discuss the characteristics of high-level and low-level programming languages that make them suitable for developing software for the smartphone.

You should consider:

- the built-in devices
- the applications.

(6)

Area with horizontal dotted lines for writing the answer.



DO NOT WRITE IN THIS AREA

DO NOT WRITE IN THIS AREA

DO NOT WRITE IN THIS AREA

(Total for Question 4 = 17 marks)



5 Issues and impact

- (a) A replacement cycle is the time between the purchase of a device and the purchase of its replacement.

Describe **one** impact the length of replacement cycles has on the environment.

(2)

.....

.....

.....

.....

.....

.....

- (b) Intellectual property is protected by different methods.

Complete the table with the method of protection for **each** type of intellectual property.

(2)

Intellectual property	Method of protection
A hardware invention	
An advertising slogan	

- (c) Robots use sensors to collect data about their surroundings in order to carry out actions independently.

Explain **one** way that a modern car is a robot.

(2)

.....

.....

.....

.....



(d) Anti-malware protects systems from viruses.

Draw a flowchart in the box provided to show how anti-malware detects a virus in a file and what it does with the file.

Here are some flowchart symbols:

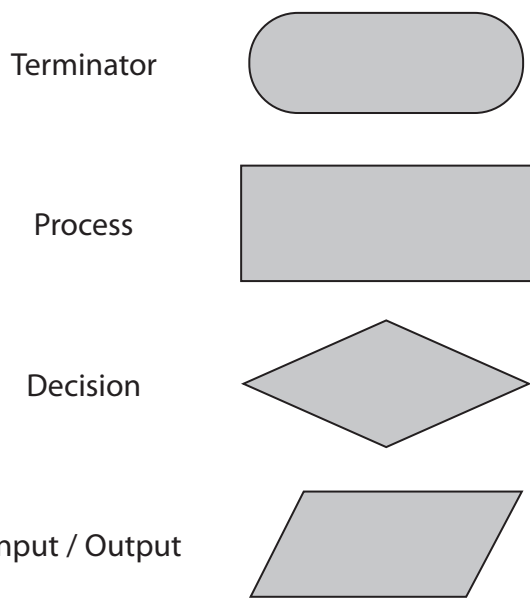

You may not need to use all the flowchart symbols.

(6)



DO NOT WRITE IN THIS AREA

DO NOT WRITE IN THIS AREA

DO NOT WRITE IN THIS AREA

Empty answer box for Question 5.

(Total for Question 5 = 12 marks)

TOTAL FOR PAPER = 75 MARKS



DO NOT WRITE IN THIS AREA

DO NOT WRITE IN THIS AREA

DO NOT WRITE IN THIS AREA

BLANK PAGE

