

Please write clearly in block capitals.

Centre number

--	--	--	--	--

Candidate number

--	--	--	--

Surname

Forename(s)

Candidate signature

I declare this is my own work.

GCSE COMBINED SCIENCE: SYNERGY

F

Foundation Tier Paper 4 Physical Sciences

Tuesday 13 June 2023

Morning

Time allowed: 1 hour 45 minutes

Materials

For this paper you must have:

- a ruler
- a protractor
- a scientific calculator
- the periodic table (enclosed)
- the Physics Equations Sheet (enclosed).

Instructions

- Use black ink or black ball-point pen. Pencil should only be used for drawing.
- Fill in the boxes at the top of this page.
- Answer **all** questions in the spaces provided. Do not write outside the box around each page or on blank pages.
- If you need extra space for your answer(s), use the lined pages at the end of this book. Write the question number against your answer(s).
- Do all rough work in this book. Cross through any work you do not want to be marked.
- In all calculations, show clearly how you work out your answer.

Information

- The maximum mark for this paper is 100.
- The marks for questions are shown in brackets.
- You are expected to use a calculator where appropriate.
- You are reminded of the need for good English and clear presentation in your answers.

For Examiner's Use	
Question	Mark
1	
2	
3	
4	
5	
6	
7	
8	
9	
10	
TOTAL	



0 1

The stopping distance of a vehicle depends on the thinking distance and the braking distance.

0 1 . **1**

What is meant by 'thinking distance'?

[1 mark]

Tick (✓) **one** box.

The distance travelled before a vehicle stops.

The distance travelled while the driver reacts.

The time taken for a driver to react.

The time taken for the vehicle to stop.

0 1 . **2**

What would increase the **braking distance** of a vehicle?

[1 mark]

Tick (✓) **one** box.

Ice on the road surface

Sunny weather

Using a mobile phone while driving



0 1 . 3 What is the name of the force which causes the vehicle to decelerate when the brakes are applied?

[1 mark]

Tick (✓) **one** box.

Friction

Upthrust

Weight

Question 1 continues on the next page

Turn over ►



Figure 1 shows how the braking distance of two cars varies with speed.

Figure 1

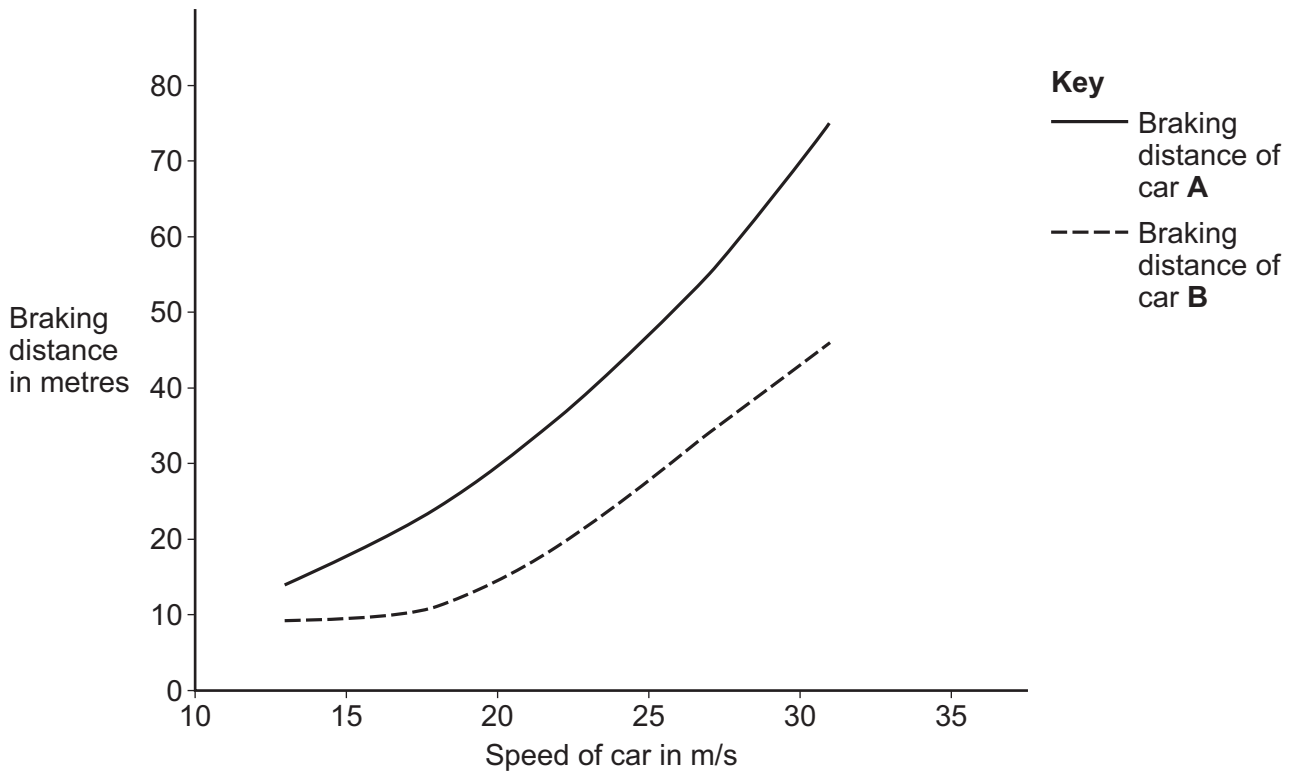

0 1 . 4 How does the braking distance of the two cars vary with speed?

[1 mark]

Tick (✓) **one** box.

The braking distance decreases as speed increases.

The braking distance is not affected by speed.

The braking distance increases as speed increases.



To make a fair comparison between the braking distance of the two cars, the mass of each car was the same.

0 1 . 5 Calculate the weight of a car.

mass = 850 kg

gravitational field strength = 9.8 N/kg

[3 marks]

Use the equation:

$$\text{weight} = \text{mass} \times \text{gravitational field strength}$$

Choose the unit from the box.

kilograms

metres

newtons

Weight = _____ Unit _____

Question 1 continues on the next page

Turn over ►



0 1 . **6** Which **two** variables should be kept the same to make a fair comparison of the braking distance of the two cars?

[2 marks]

Tick (✓) **two** boxes.

The age of the driver

The caffeine intake of the driver

The colour of the car

The number of people in the car

The type of road surface

0 1 . **7** The mass of each car was 850 kg.

At one speed the deceleration of one of the cars was 10.7 m/s^2 .

Calculate the mean braking force on the car.

Use the equation:

$$\text{mean braking force} = \text{mass} \times \text{deceleration}$$

[2 marks]

Mean braking force = _____ N



0 1 . 8 **Table 1** shows the braking force on each car at a speed of 31 m/s.

Table 1

Car	Braking force in N
A	5450
B	8880

The braking distance of car **A** was longer than the braking distance of car **B** at a speed of 31 m/s.

Explain why.

Use data from **Table 1**.

[2 marks]

13

Turn over for the next question

Turn over ►



0 2

This question is about Group 7 elements.

Figure 2 shows some Group 7 elements in the periodic table.

Figure 2

19 F fluorine 9
35.5 Cl chlorine 17
80 Br bromine 35
127 I iodine 53

0 2 . 1

What is the name of the Group 7 elements?

[1 mark]

Tick (✓) **one** box.

Alkali metals

Halogens

Noble gases

0 2 . 2

Which element in **Figure 2** has the highest melting point?

[1 mark]



0 2 . 3 A fluorine atom has 9 electrons.

What is the electronic structure of a fluorine atom?

[1 mark]

Tick (✓) **one** box.

2,3,4

2,7

4,3,2

7,2

0 2 . 4 What type of structure does chlorine have?

[1 mark]

Tick (✓) **one** box.

Giant covalent

Ionic lattice

Small molecules

0 2 . 5 Name the compound produced when potassium reacts with iodine.

[1 mark]

Question 2 continues on the next page

Turn over ►



- 0 2 . 6** A less reactive Group 7 element can be displaced from an aqueous solution of its salt by a more reactive Group 7 element.

Complete **Table 2** to show if a reaction occurs when the element is added to the aqueous solution.

Use:

- ✓ where a reaction occurs
- ✗ where there is no reaction.

[3 marks]

Table 2

Element	Aqueous solution		
	Sodium fluoride	Sodium chloride	Sodium bromide
Fluorine	✗		
Chlorine		✗	
Bromine			✗

8



Turn over for the next question

*Do not write
outside the
box*

**DO NOT WRITE ON THIS PAGE
ANSWER IN THE SPACES PROVIDED**

Turn over ►



0 3

A student investigated resistance in a circuit.

The student measured:

- the current in the resistor with an ammeter
- the potential difference across the resistor with a voltmeter.

0 3 . 1

Figure 3 shows a circuit diagram.

Figure 3

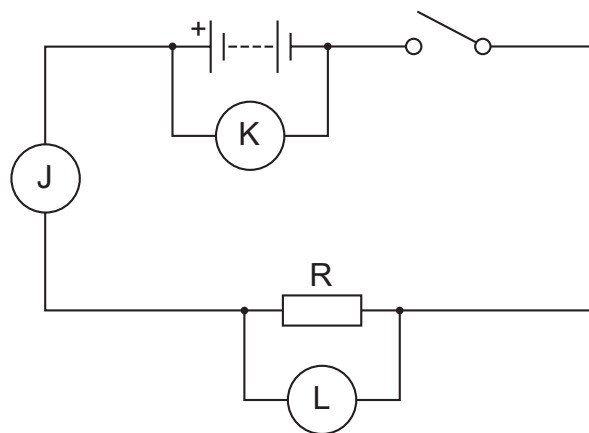

Which letter on **Figure 3** shows the correct position for the ammeter to measure the current in the resistor?

[1 mark]

Tick (✓) **one** box.

J K L



0 3 . 2 Draw the circuit symbol for a voltmeter in the box below.

[1 mark]

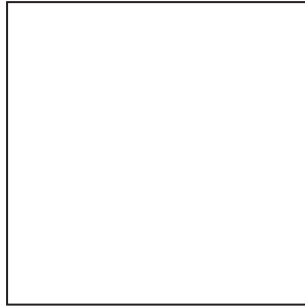

Question 3 continues on the next page

Turn over ►



The student changed the number of identical resistors in the circuit.

The student calculated the total resistance of the resistors.

Figure 4 shows the results.

Figure 4

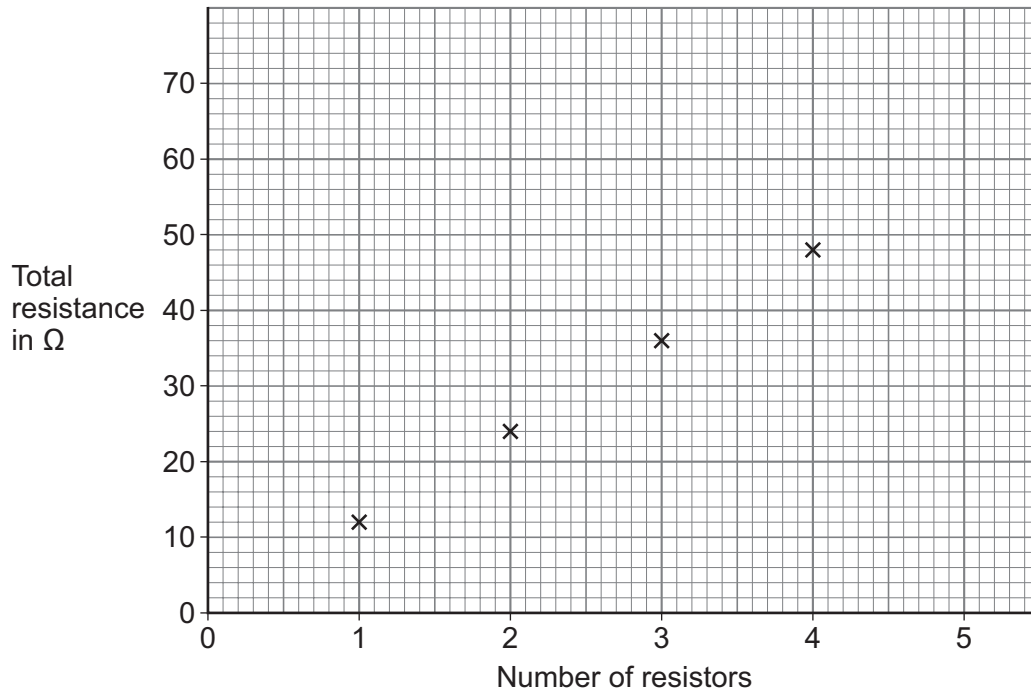

0 3 . 3 Draw a line of best fit on **Figure 4**.

[1 mark]

0 3 . 4 Predict the total resistance when 5 resistors were connected in the circuit.

You should extend your line of best fit.

[1 mark]

Total resistance = _____ Ω



0 3 . 5 How were the identical resistors connected in the student's circuit?

Use **Figure 4**.

[2 marks]

Tick (✓) **one** box.

The resistors were connected in parallel.

The resistors were connected in series.

The resistors were connected in series and in parallel.

Give a reason for your answer.

0 3 . 6 The potential difference across the battery was 3.0 V.

The maximum current in the circuit in the student's investigation was 0.25 A.

Calculate the maximum power output of the battery in the student's investigation.

Use the equation:

$$\text{power} = \text{potential difference} \times \text{current}$$

[2 marks]

Power = _____ W

8

Turn over ►



0 4

This question is about metal extraction and recycling.

Most metals are found in the Earth as metal compounds.

0 4 - **1**

Why is gold found in the Earth as the metal itself?

[1 mark]

0 4 - **2**

How is aluminium extracted from aluminium compounds?

[1 mark]

Tick (✓) **one** box.

By displacement

By electrolysis

By reduction with carbon



Iron is extracted from iron oxide.

0 4 . 3 An oxide ion is an oxygen atom that has gained two electrons.

What is the formula of an oxide ion?

[1 mark]

Tick (✓) **one** box.

O₂ O²⁻ O²⁺

0 4 . 4 Iron oxide is heated with carbon to produce iron and carbon dioxide.

The word equation for the reaction is:

iron oxide + carbon → iron + carbon dioxide

Which substance is oxidised in the reaction?

[1 mark]

Question 4 continues on the next page

Turn over ►



Iron is used to make steel.

Scrap steel can be recycled.

0 4 . 5 Give **two** environmental advantages of recycling scrap steel instead of making new steel from iron.

[2 marks]

1 _____

2 _____

0 4 . 6 **Table 3** shows information about scrap steel in one year.

Table 3

	Mass in millions of kg
Scrap steel recycled	420
Total scrap steel	560

Calculate the percentage (%) of scrap steel that was recycled in one year.

[2 marks]

Percentage = _____ %



0 4 . 7 Figure 5 shows metal food and drink cans.

Figure 5



The metal cans are made from steel or aluminium.

Which property of steel means that steel can be separated from aluminium at a recycling centre?

[1 mark]

9

Turn over for the next question

Turn over ►



0 5

A student investigated the rate of the reaction between calcium carbonate and hydrochloric acid.

The word equation for the reaction is:



Figure 6 shows the apparatus.

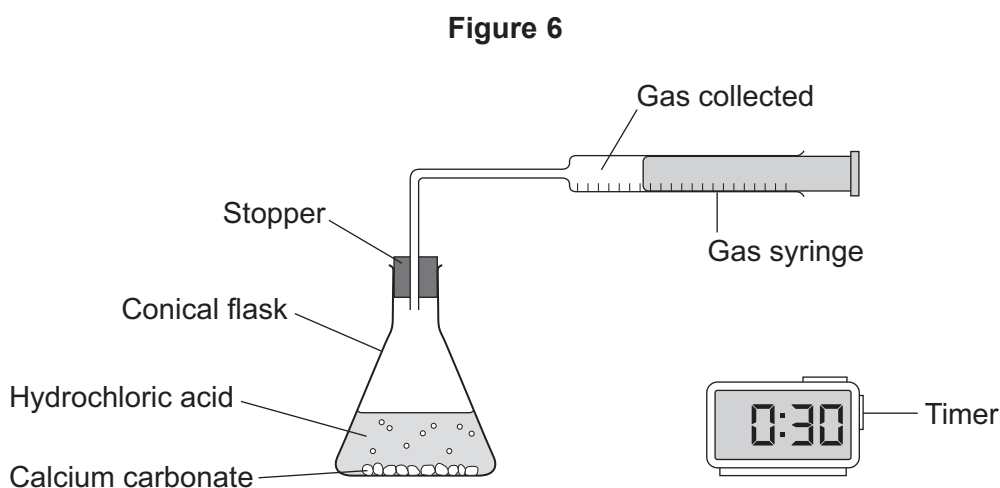

This is the method used.

1. Add 50 cm³ of hydrochloric acid to the conical flask.
2. Add 2.0 g of calcium carbonate to the conical flask.
3. Immediately insert the stopper into the conical flask and start the timer.
4. Record the volume of gas collected in the gas syringe every 30 seconds.
5. Stop recording when the volume of gas in the gas syringe does not change.



0 5 . 1 Which piece of equipment is the most suitable to measure the volume of hydrochloric acid?

[1 mark]

Tick (✓) **one** box.

Beaker

Measuring cylinder

Test tube

0 5 . 2 Name **one** piece of equipment that can be used to measure the mass of calcium carbonate.

[1 mark]

0 5 . 3 Why must the stopper be inserted **immediately** after the reactants are added to the flask?

[1 mark]

Question 5 continues on the next page

Turn over ►



Figure 7 shows the results.

Figure 7

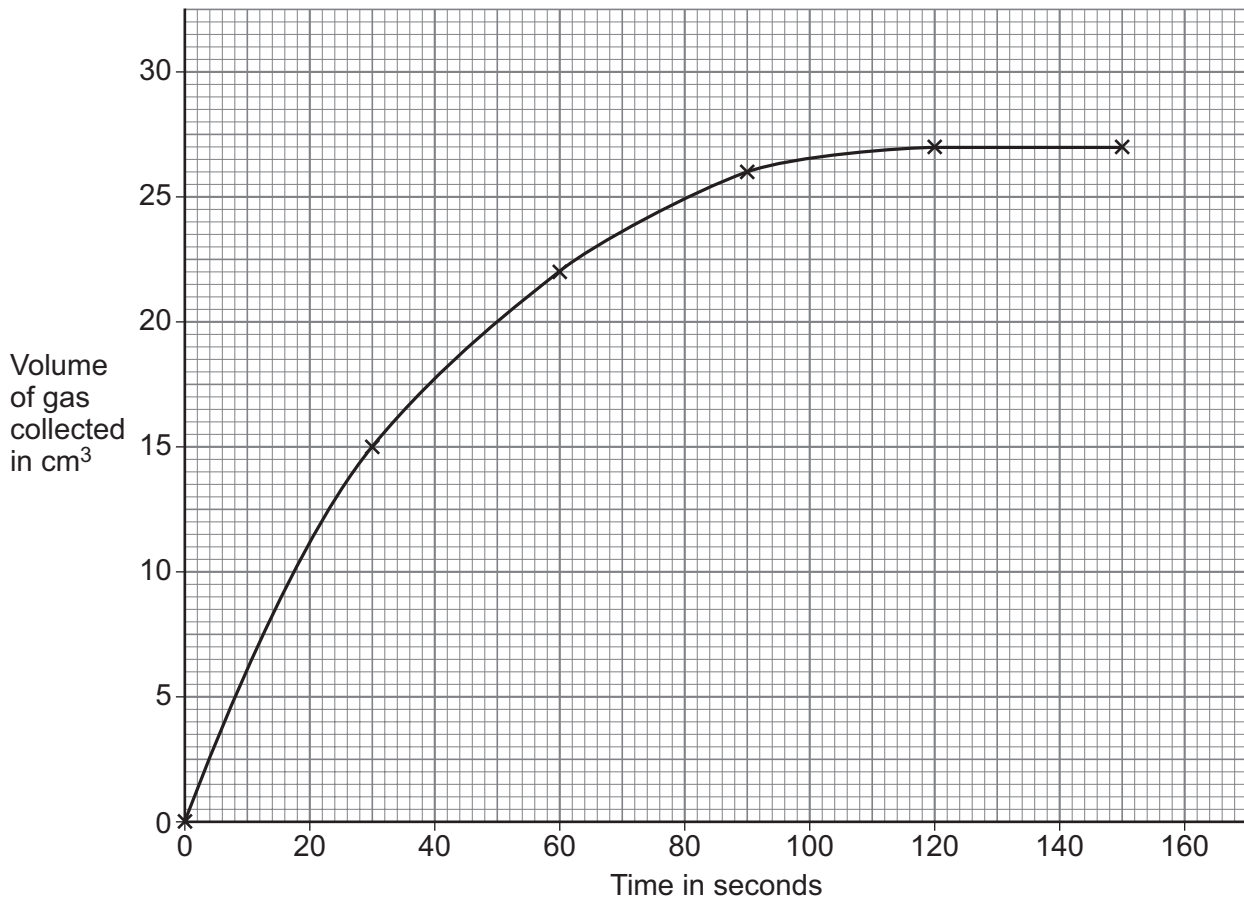

0 5 . 4 Describe the trend for the volume of gas collected.

Use Figure 7.

[2 marks]



0 5 . 5 Determine the mean rate of reaction from 0 to 30 seconds.

Use **Figure 7**.

Use the equation:

$$\text{mean rate of reaction} = \frac{\text{volume of gas collected}}{\text{time taken}}$$

Choose the unit from the box.

[4 marks]

cm³/s	s/cm³	scm³
-------------------------	-------------------------	------------------------

Mean rate of reaction = _____ Unit _____

0 5 . 6 The student repeated the investigation using hydrochloric acid of higher concentration.

Complete the sentences.

Choose answers from the box.

[2 marks]

decreases	stays the same	increases
------------------	-----------------------	------------------

When the concentration of hydrochloric acid increases, the rate of reaction increases.

This is because the mean distance between particles _____.

Therefore the frequency of collisions between particles _____.

Question 5 continues on the next page

Turn over ►



0 5 . 7 What is the minimum amount of energy that particles must have to react?

[1 mark]

Tick (✓) **one** box.

Activation energy

Kinetic energy

Potential energy

12



0 6

Permanent magnets have a magnetic field around them.

0 6 . 1

The Earth has a magnetic field.

Which part of the Earth's internal structure creates the magnetic field?

[1 mark]

Tick (✓) **one** box.

- The crust
- The mantle
- The outer core

0 6 . 2

A magnetic compass contains a bar magnet.

Which diagram shows the magnetic field around a bar magnet?

[1 mark]

Tick (✓) **one** box.

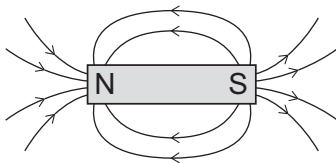

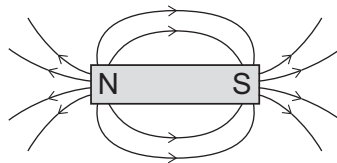

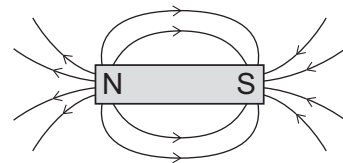

Question 6 continues on the next page

Turn over ►



A student wrapped insulated wire around an iron bar to make an electromagnet.

Figure 8 shows the electromagnet held in a clamp and connected to a circuit.

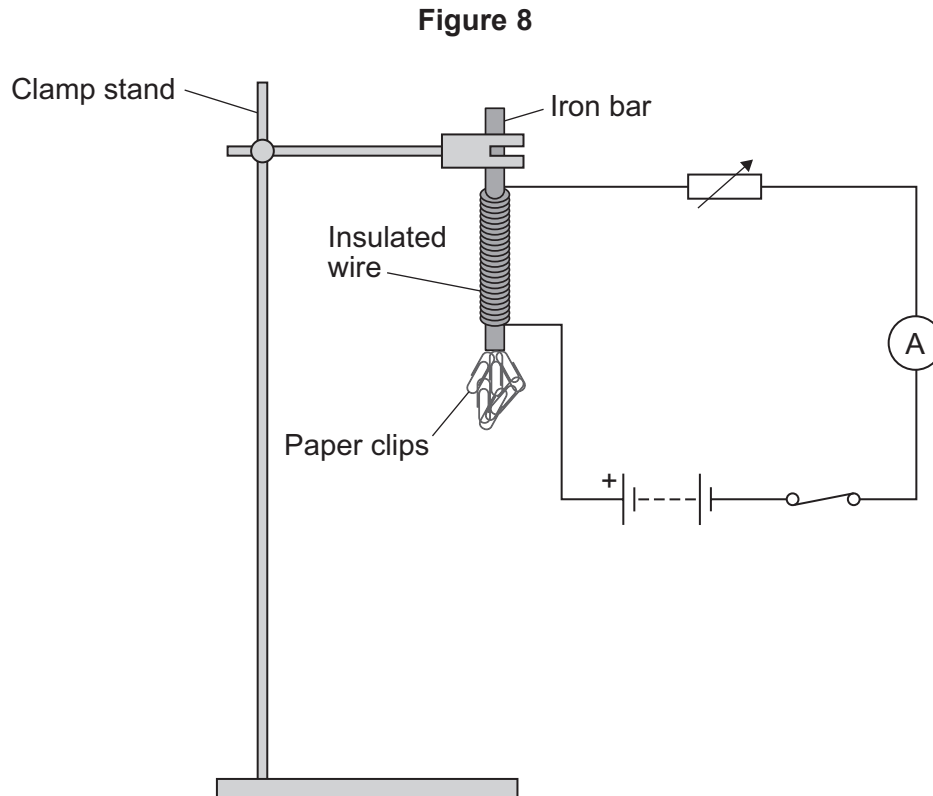

When the switch was closed, the electromagnet attracted paper clips.

The student investigated how the number of turns of wire on the iron bar affected the strength of the electromagnet.

This is the method used.

1. Wrap 20 turns of wire around the iron bar.
2. Hold the paper clips near the bottom of the electromagnet.
3. Close the switch.
4. Count the number of paper clips the electromagnet picks up.
5. Open the switch.
6. Repeat steps 1 to 5, but with more turns of wire around the iron bar.



0 6 . 3 The student used the same value of current throughout the investigation.

What type of variable was the current?

[1 mark]

Tick (✓) **one** box.

Control variable

Dependent variable

Independent variable

Question 6 continues on the next page

Turn over ►



Table 4 shows the results.

When there was no wire wrapped around the iron bar, no paper clips were picked up.

Table 4

Number of turns of wire	Number of paper clips picked up			
	Test 1	Test 2	Test 3	Mean
0	0	0	0	0
20	5	6	7	6
40	19	19	7	19
60	33	35	37	35
80	54	52	56	54

0 6 . 4 Draw a ring around the anomalous result in **Table 4**.

[1 mark]

0 6 . 5 The student did **not** take another reading to replace the anomalous result.

What did the student do with the anomalous result when calculating the mean?

[1 mark]



Figure 9 is a graph of the results.

Figure 9

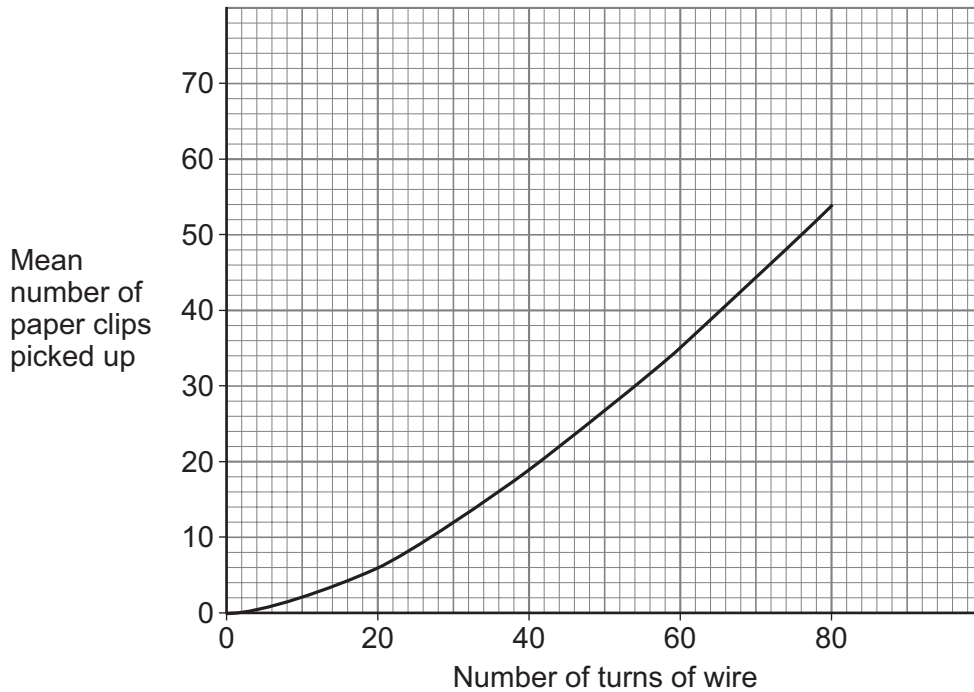

0 6 . 6

How many paper clips would be picked up when 70 turns of wire are wrapped around the iron bar?

[1 mark]

Number of paper clips = _____

0 6 . 7

The investigation was repeated using a larger current.

Draw a line on **Figure 9** to show the expected results.

[2 marks]

8

Turn over ►



0 7

A student threw a ball vertically upwards into the air.

Figure 10 is a velocity-time graph of the ball's motion after leaving the student's hand until the ball reaches maximum height.

Air resistance has been ignored.

Figure 10

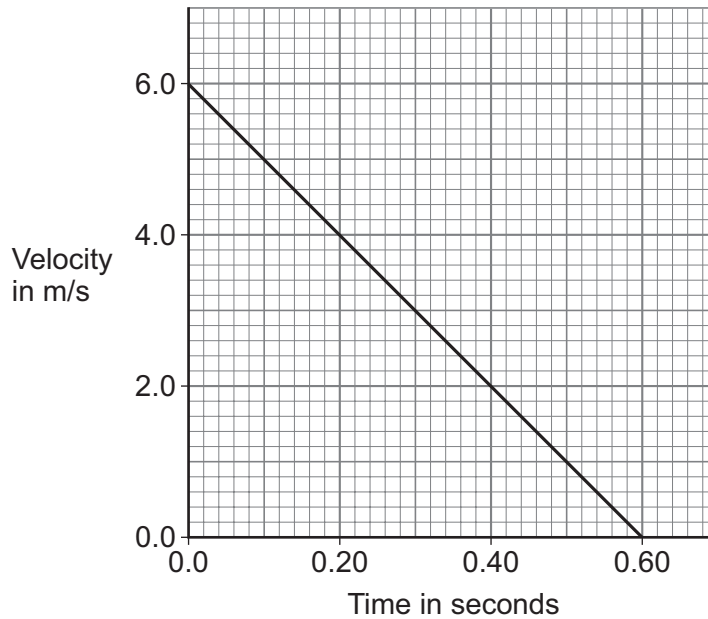

0 7 . 1

The maximum height is equal to the area between the line and the horizontal axis.

Calculate the maximum height reached by the ball.

Use **Figure 10**.

[2 marks]

Maximum height = _____ m



0 7 . 2 Calculate the gradient of the line in **Figure 10**.

Use the equation:

$$\text{gradient} = \frac{\text{change in y value}}{\text{change in x value}}$$

[2 marks]

Gradient = _____

0 7 . 3 What does the gradient of the line in **Figure 10** represent?

[1 mark]

Tick (✓) **one** box.

The deceleration of the ball.

The distance travelled by the ball.

The speed of the ball.

Question 7 continues on the next page

Turn over ►



0 7 . 4 In **Figure 10** air resistance was ignored.

What would happen to the motion of the ball in **Figure 10** if air resistance was included?

[2 marks]

Tick (✓) **two** boxes.

The deceleration would be greater.

The final speed would be greater.

The initial kinetic energy would be less.

The initial velocity would be less.

The maximum height of the ball would be less.



The student threw a second ball vertically upwards into the air.

The maximum height reached by the second ball was 5.0 m.

The student caught the ball at the same height that the ball was thrown from.

The displacement of the ball is the straight-line distance between the start height and the end height.

0 7 . 5 What is the total distance the ball travels?

[1 mark]

Tick (✓) **one** box.

0.0 m

5.0 m

10.0 m

0 7 . 6 What is the displacement of the ball when the student catches the ball?

[1 mark]

Tick (✓) **one** box.

0.0 m

5.0 m

10.0 m



There are no questions printed on this page

*Do not write
outside the
box*

**DO NOT WRITE ON THIS PAGE
ANSWER IN THE SPACES PROVIDED**



0 8

This question is about hydrocarbon fuels.

The **complete** combustion of a hydrocarbon fuel produces carbon dioxide and one other product.

0 8 . 1

Name the other product of the **complete** combustion of a hydrocarbon fuel.

Do **not** refer to carbon dioxide.

[1 mark]

0 8 . 2

Describe the test for carbon dioxide.

Give the result if carbon dioxide is present.

[2 marks]

Test _____

Result _____

Question 8 continues on the next page

Turn over ►

The combustion of hydrocarbon fuels releases energy.

A student investigated the energy released by three different fuels **A**, **B** and **C**.

Figure 11 shows the apparatus.

Figure 11

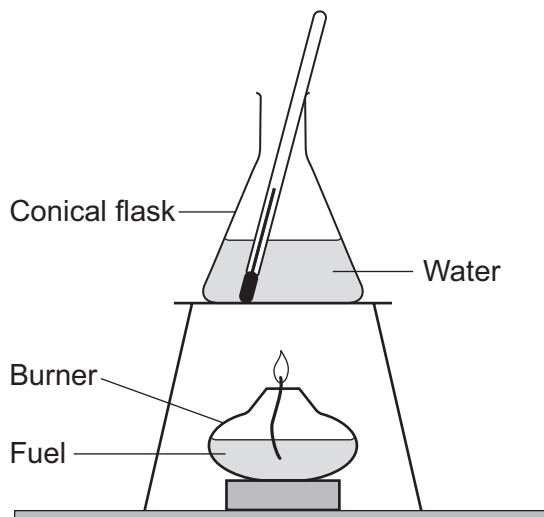

This is part of the method used.

1. Put fuel **A** in the burner.
2. Pour 100 cm^3 of water into the conical flask.
3. Record the temperature of the water.
4. Light the fuel and heat the water for 5 minutes.
5. Record the final temperature of the water.
6. Repeat steps 1 to 5 using fuel **B** and then using fuel **C**.



0 8 . 3 The student also determined the mass of fuel burnt.

Describe how the student could determine the mass of fuel burnt.

[2 marks]

0 8 . 4 Give **one** control variable in the investigation.

[1 mark]

0 8 . 5 **Table 5** shows the results.

Table 5

Fuel	Mass of fuel burnt in grams	Temperature increase of water in °C
A	1.72	40
B	1.65	45
C	1.23	50

Explain how **Table 5** shows that fuel **C** released the most energy per gram of fuel.

[2 marks]

Question 8 continues on the next page

Turn over ►



0 8 . 6 The student repeated the investigation with screens around the apparatus.

Figure 12 shows the apparatus with screens.

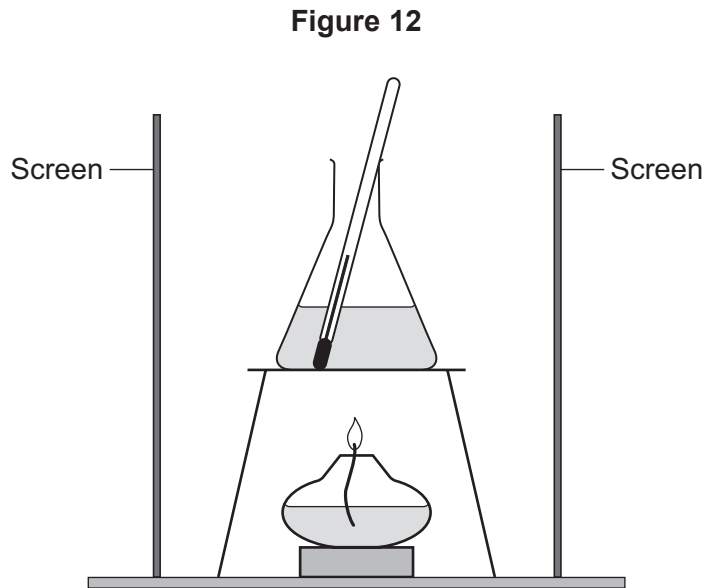

Give **one** reason why putting screens around the apparatus could improve the accuracy of the investigation.

[1 mark]

0 8 . 7 How would stirring the water improve the accuracy of the investigation?

[1 mark]

10



Turn over for the next question

*Do not write
outside the
box*

**DO NOT WRITE ON THIS PAGE
ANSWER IN THE SPACES PROVIDED**

Turn over ▶



0 9

A solar cell generates a potential difference when light shines on its surface.

A student investigated how the potential difference varied with the light intensity at the surface of the solar cell.

Figure 13 shows some of the equipment used by the student.

Figure 13

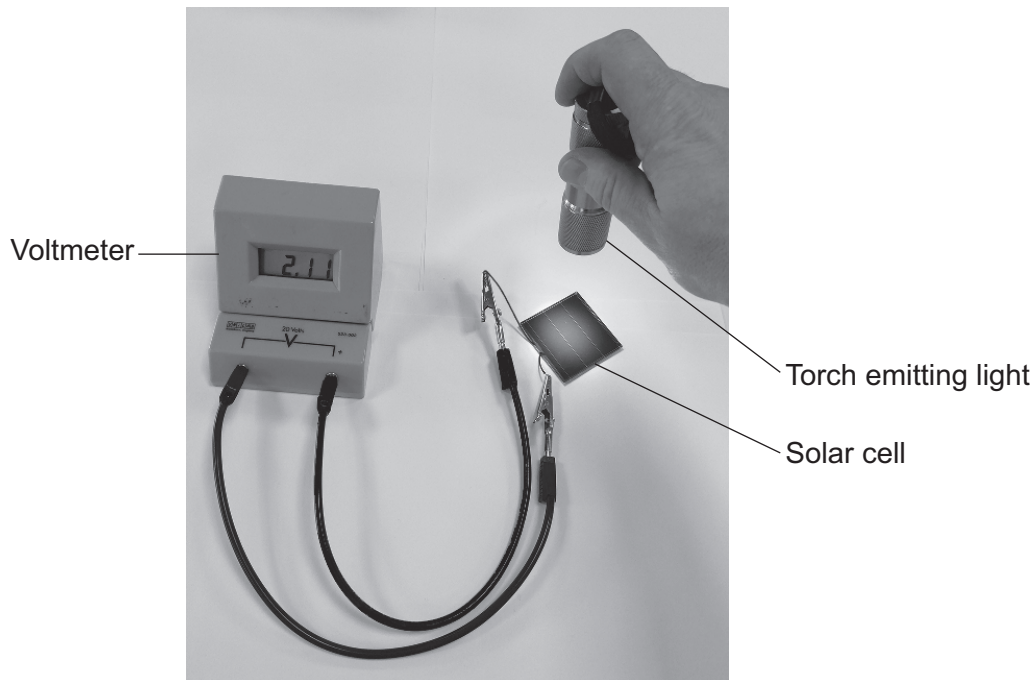

The voltmeter displayed the potential difference generated by the solar cell.

The student varied the light intensity by changing the height of the torch above the solar cell.

Figure 14 shows the results.

Figure 14

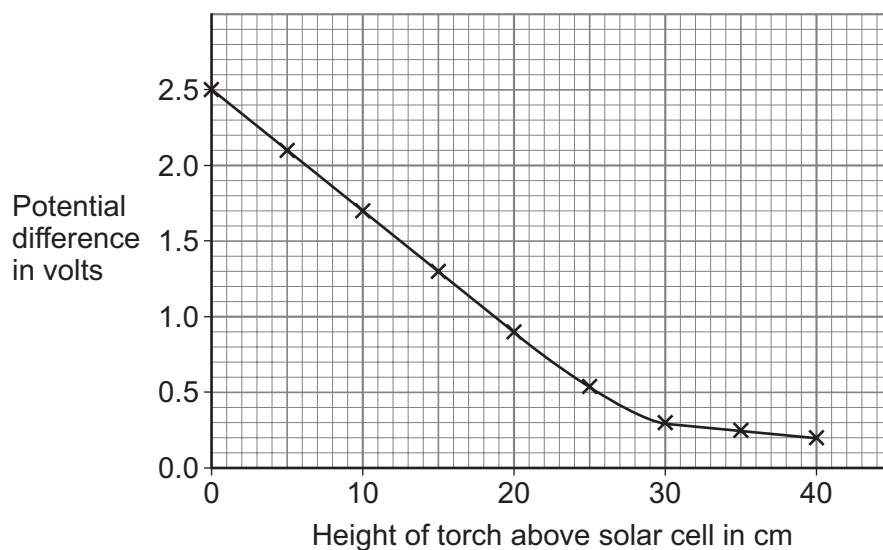

The circuit symbol for a solar cell is:

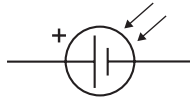

Figure 15 shows the solar cell in a circuit with an LED and a resistor.

Figure 15

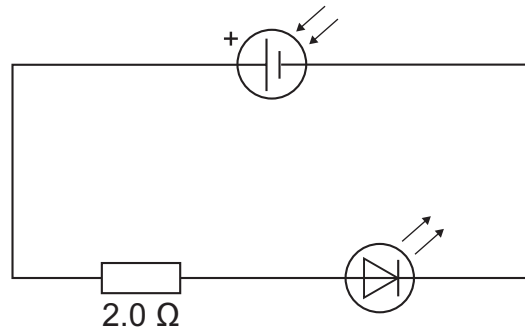
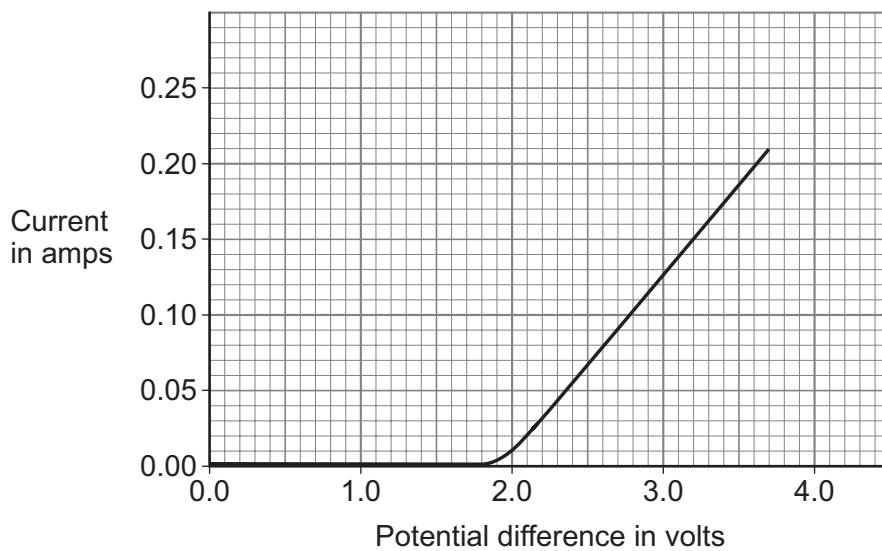

Figure 16 shows how the current in the LED varies with the potential difference across the LED.

Figure 16



- 0 9 . 2** What is the range of potential difference values for which the LED emits light in **Figure 16**?

[1 mark]

Range of values = _____ to _____ V

Use the Physics Equations Sheet to answer questions **09.3** and **09.4**.

- 0 9 . 3** Which equation links current (I), potential difference (V) and resistance (R)?

[1 mark]

Tick (✓) **one** box.

$V = IR$

$V = I^2 R$

$V = IR^2$

$V = \frac{I}{R}$

- 0 9 . 4** Determine the resistance of the LED when the potential difference across the LED is 2.7 V.

Use **Figure 16**.

[4 marks]

Resistance = _____ Ω

- 0 9 . 5** Describe how the resistance of the LED varies as the p.d. increases from 0 V to 3.7 V.

Use data from **Figure 16**.

[2 marks]

Turn over ►



1 0

Figure 17 shows two different designs of wind turbine.

Figure 17

Three-blade wind turbine



Bladeless wind turbine



To generate electricity, the three-blade wind turbine rotates about an axis.

To generate electricity, the bladeless wind turbine oscillates from side to side.

Table 6 gives information about the two designs.

Table 6

Feature	Three-blade turbine	Bladeless turbine
Lubrication needed	Yes	No
Maintenance costs	High	Low
Noise level	High	Low
Power output	High	Low
Risk to flying birds	Yes	No



1 0 . 1

Which feature of the three-blade turbine is an advantage compared with the bladeless turbine?

Use **Table 6**.

Give a reason for your answer.

[2 marks]

Feature _____

Reason _____

Question 10 continues on the next page

Turn over ►



To generate electricity, the bladeless wind turbine oscillates from side to side.

Figure 18 shows the direction of the oscillations of the bladeless wind turbine.

Figure 18

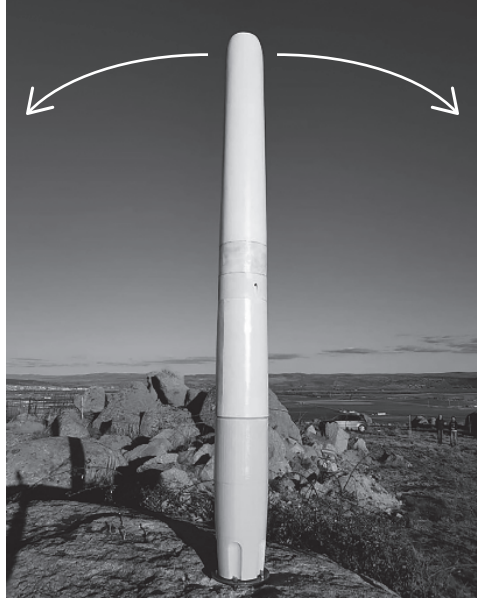
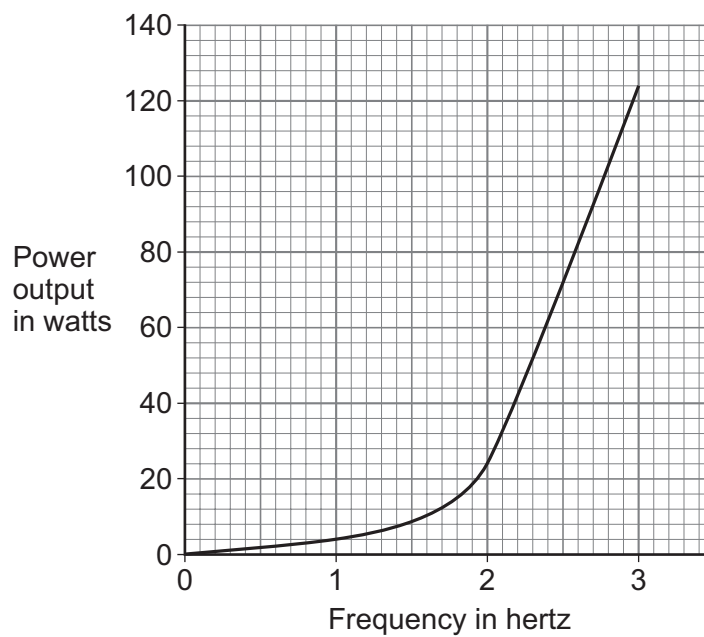

Figure 19 shows how the power output of the bladeless turbine varies with the frequency of the oscillation.

Figure 19



1	0	.	2
---	---	---	---

Describe how the power output of the bladeless turbine varies with frequency.

[2 marks]

Question 10 continues on the next page

Turn over ►



The energy from wind turbines can be used to recharge a battery.

Use the Physics Equations Sheet to answer questions **10.3** and **10.4**.

103 Which equation links charge flow (Q), current (I) and time (t)?

[1 mark]

Tick (✓) **one** box.

$$Q = I t$$

$$Q = I t^2$$

$$Q = I^2 t$$

$$Q = \frac{I}{t}$$

104 To fully recharge the battery, a charge of 216 000 C needs to flow through the battery.

The current in the battery is 5.0 A.

Calculate the time taken to fully recharge the battery.

Give the unit.

[4 marks]

Time taken = _____ Unit _____

9

END OF QUESTIONS



There are no questions printed on this page

*Do not write
outside the
box*

**DO NOT WRITE ON THIS PAGE
ANSWER IN THE SPACES PROVIDED**



