

Please write clearly in block capitals.

Centre number

--	--	--	--	--

Candidate number

--	--	--	--

Surname

---

Forename(s)

---

Candidate signature

---

I declare this is my own work.

# GCSE CHEMISTRY

# H

Higher Tier Paper 2

Tuesday 11 June 2024

Morning

Time allowed: 1 hour 45 minutes

## Materials

For this paper you must have:

- a ruler
- a scientific calculator
- the periodic table (enclosed).

## Instructions

- Use black ink or black ball-point pen.
- Pencil should only be used for drawing.
- Fill in the boxes at the top of this page.
- Answer **all** questions in the spaces provided. Do not write outside the box around each page or on blank pages.
- If you need extra space for your answer(s), use the lined pages at the end of this book. Write the question number against your answer(s).
- Do all rough work in this book. Cross through any work you do not want to be marked.

## Information

- The maximum mark for this paper is 100.
- The marks for questions are shown in brackets.
- You are expected to use a calculator where appropriate.
- In all calculations, show clearly how you work out your answer.
- You are reminded of the need for good English and clear presentation in your answers.

For Examiner's Use

Question	Mark
1	
2	
3	
4	
5	
6	
7	
8	
9	
<b>TOTAL</b>	



0	1
---	---

A student investigated an aqueous solution of a salt.

The student identified that the salt solution contained only sodium ions and chloride ions.

0	1	.	1
---	---	---	---

Describe a test to identify sodium ions.

Give the result of the test.

**[2 marks]**

Test for sodium ions \_\_\_\_\_

\_\_\_\_\_

Result \_\_\_\_\_

\_\_\_\_\_

0	1	.	2
---	---	---	---

Describe a test to identify chloride ions.

Give the result of the test.

**[2 marks]**

Test for chloride ions \_\_\_\_\_

\_\_\_\_\_

Result \_\_\_\_\_

\_\_\_\_\_



The student determined the concentration of sodium chloride in the salt solution.

This is the method used.

1. Weigh an empty evaporating dish.
2. Add 25.0 cm<sup>3</sup> of the salt solution into the evaporating dish.
3. Heat the evaporating dish and contents.
4. Weigh the evaporating dish and contents.
5. Repeat steps 3 to 4 until there is no further change in mass.
6. Repeat steps 1 to 5 three more times.

0 1 . 3

Why did the student heat the evaporating dish and contents until the mass did not change?

[1 mark]

---

---

0 1 . 4

How did the student calculate the mass of solid sodium chloride remaining after steps 1 to 5?

[1 mark]

Tick (✓) **one** box.

Mass of 25 cm<sup>3</sup> of salt solution + mass of empty evaporating dish

Mass of 25 cm<sup>3</sup> of salt solution – mass of empty evaporating dish

Mass of evaporating dish and dry contents + mass of empty evaporating dish

Mass of evaporating dish and dry contents – mass of empty evaporating dish

**Question 1 continues on the next page**

**Turn over ►**



0 1 . 5

The student calculated the concentration of sodium chloride in the salt solution.

**Table 1** shows the results.

**Table 1**

Concentration of sodium chloride in g/dm <sup>3</sup>			
Trial 1	Trial 2	Trial 3	Trial 4
35.2	34.6	36.4	33.8

The percentage by mass of sodium ions in sodium chloride is 39.3%.

Calculate the mean concentration of sodium ions in the salt solution.

**[4 marks]**

---

---

---

---

---

---

---

---

Mean concentration = \_\_\_\_\_ g/dm<sup>3</sup>

10



0 2

This question is about ammonia and nitric acid.

In the Haber process ammonia is produced from nitrogen and hydrogen.

**Figure 1** represents the Haber process.

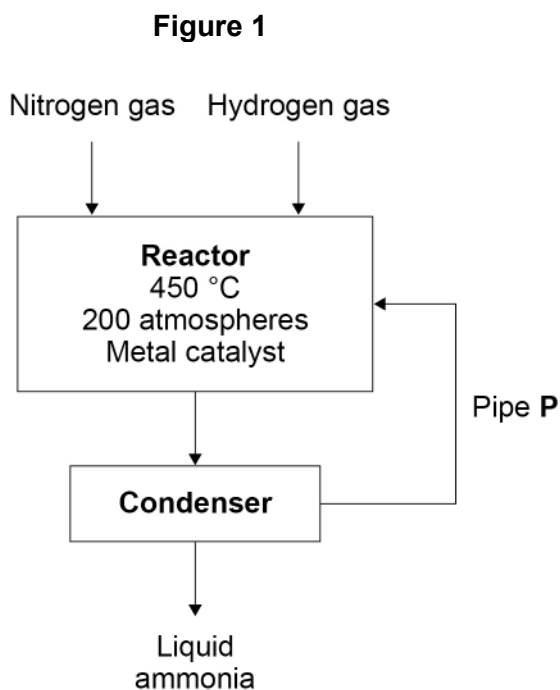

0 2 . 1

Pipe **P** links the condenser to the reactor.

Why is the condenser linked to the reactor?

Use **Figure 1**.

[1 mark]

---



---

0 2 . 2

Which metal is used as a catalyst in this reaction?

[1 mark]

---

Turn over ►



Nitric acid is produced by reacting ammonia with oxygen.

The word equation for the production of nitric acid is:

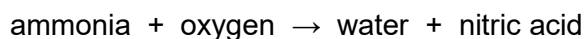

Platinum is a catalyst in this reaction.

**0 2 . 3** Describe the test for oxygen gas.

Give the result if oxygen gas is present.

**[2 marks]**

Test \_\_\_\_\_

\_\_\_\_\_

Result \_\_\_\_\_

\_\_\_\_\_

**Figure 2** represents the reaction profile of the catalysed reaction between ammonia and oxygen.

**Figure 2**

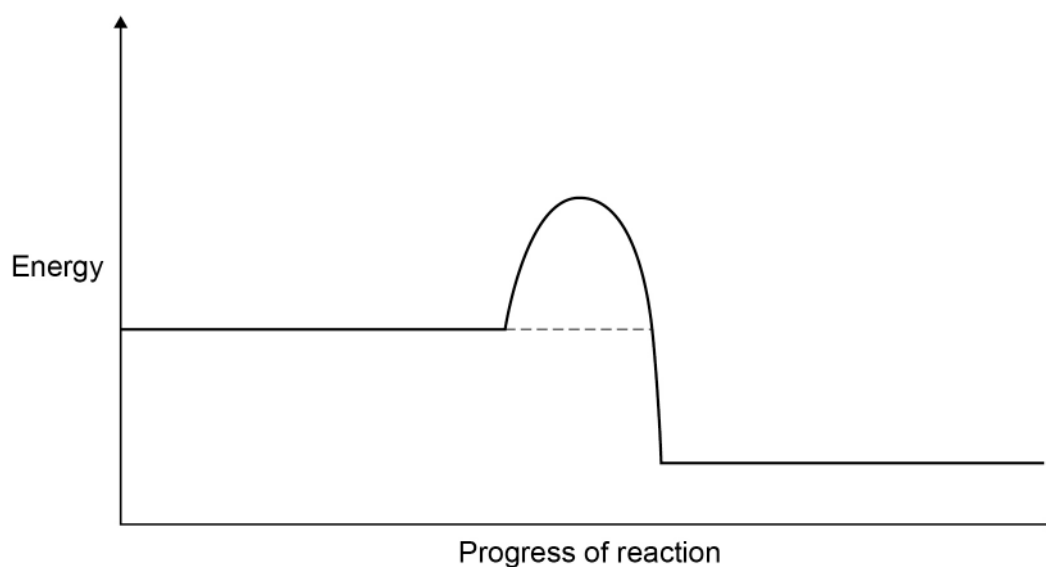

**0 2 . 4** Complete the reaction profile for the catalysed reaction in **Figure 2**.

You should:

- label the activation energy
- label the reactants and products, using the names of the reactants and products.

**[2 marks]**

**0 2 . 5** How would **Figure 2** be different if **no** catalyst was used?

**[1 mark]**

Tick (✓) **one** box.

The final energy level would be higher.

The final energy level would be lower.

The line would reach a higher peak.

The line would reach a lower peak.

**0 2 . 6** Ammonia and nitric acid react to produce the salt, ammonium nitrate.

Ammonium ions and nitrate ions both contain nitrogen.

Suggest **one** use of ammonium nitrate.

**[1 mark]**

---



---

**8**

**Turn over for the next question**

**Turn over ►**



**There are no questions printed on this page**

*Do not write  
outside the  
box*

**DO NOT WRITE ON THIS PAGE  
ANSWER IN THE SPACES PROVIDED**



**0 3**

This question is about water.

**0 3 . 1**

Hydrogen gas reacts with oxygen gas to produce water.

Water is decomposed into hydrogen gas and oxygen gas using electricity.

Which **two** words describe the reaction between hydrogen gas and oxygen gas?**[2 marks]**Tick (✓) **two** boxes.

Alloying

Combustion

Corrosion

Endothermic

Reversible

**0 3 . 2**

Water molecules break down into hydrogen ions and hydroxide ions.

The equation for the reaction is:

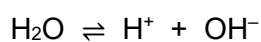

Which sentence describes this reaction at equilibrium?

**[1 mark]**Tick (✓) **one** box.

Water molecules break down at a higher rate than they reform.

Water molecules break down and reform at the same rate.

Water molecules break down at a lower rate than they reform.

**Question 3 continues on the next page****Turn over ►**

**0 3 . 3** Water collected from rivers is used in the home for drinking and flushing toilets.

Water used in the home must be potable.

Potable water is safe to drink.

Waste water produced after use in the home is called sewage.

**Figure 3** shows how water is collected from rivers and returned to rivers after use.

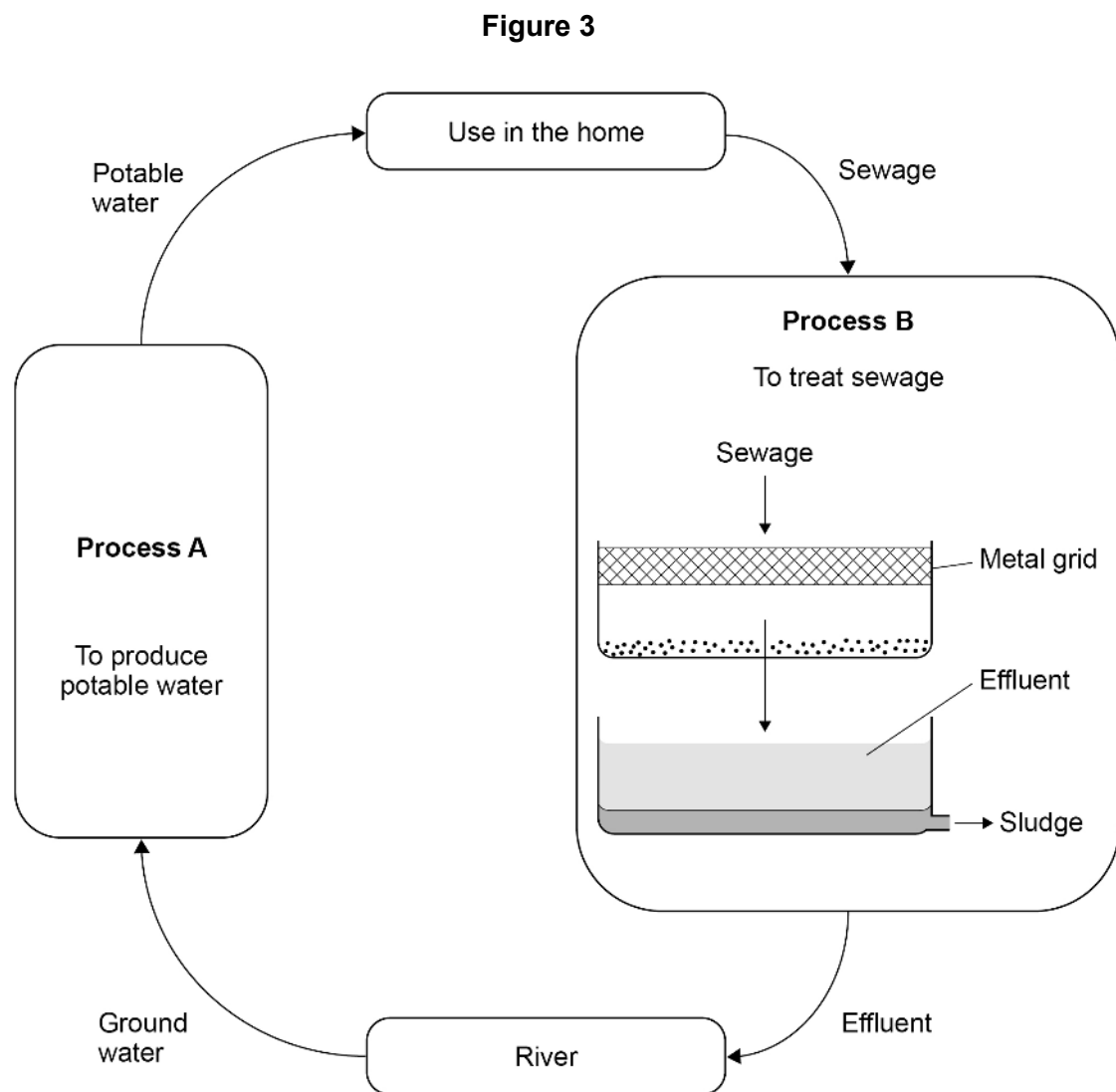



0 4

A student investigated an orange dye (A) using paper chromatography.

Figure 4 shows the results of Experiment 1 and Experiment 2 using orange dye A.

Figure 4

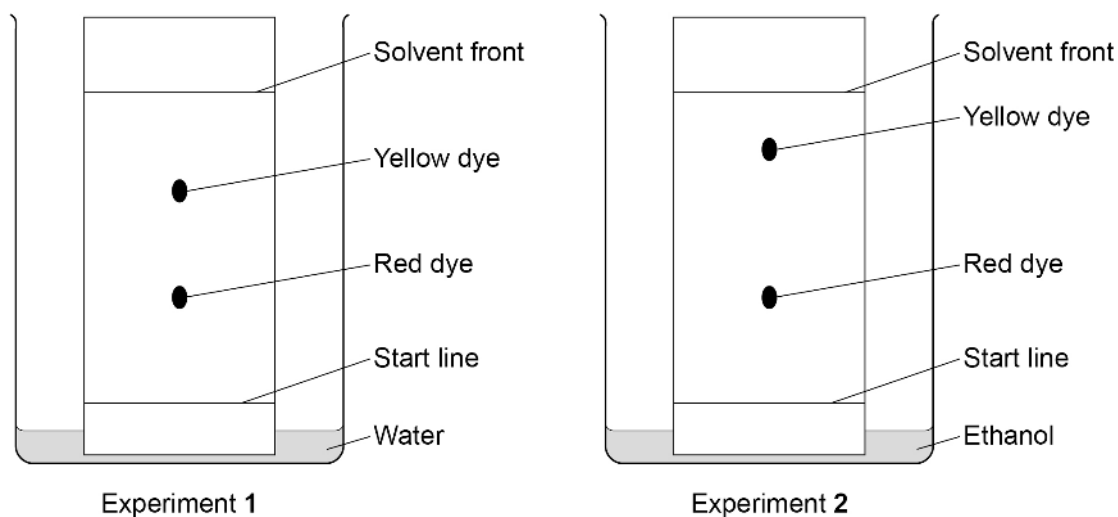

0 4 . 1

Explain why the yellow dye and red dye travel different distances in Experiment 1.

Refer to forces of attraction between the dyes and the chromatography paper in your answer.

[2 marks]

---



---



---



---



**0 4 . 2**

The student used the same type of chromatography paper in Experiment 1 and in Experiment 2.

Explain why the yellow dye is in different positions in Experiment 1 and in Experiment 2.

Use **Figure 4**.

**[3 marks]**

---

---

---

---

---

---

---

**Question 4 continues on the next page**

**Turn over ►**



**Figure 4** is repeated below.

**Figure 4** shows the results of Experiment 1 and Experiment 2 using orange dye **A**.

**Figure 4**

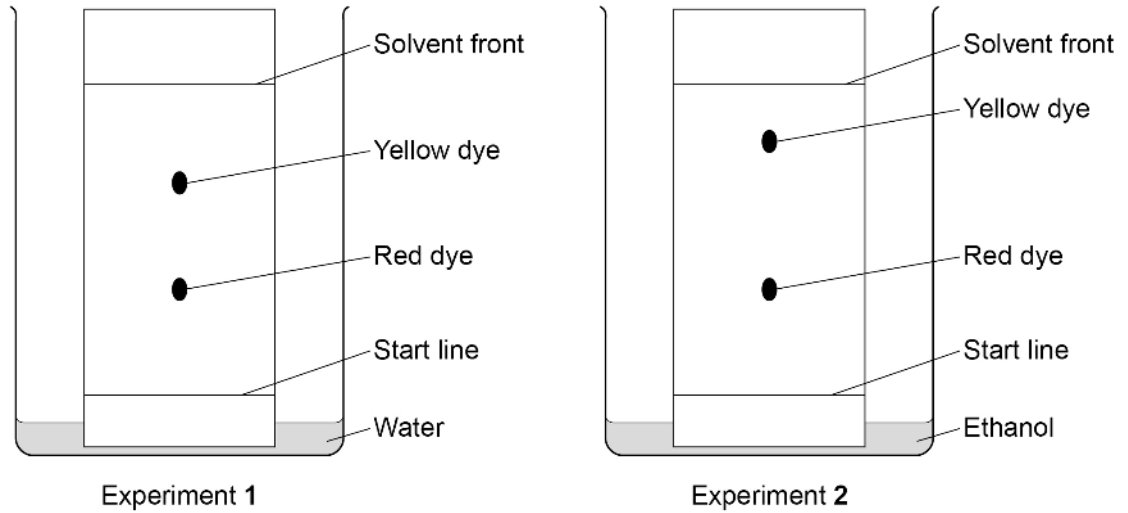

The student investigated a different orange dye (**B**).

**Figure 5** shows the results of Experiment 3 using orange dye **B**.

**Figure 5**

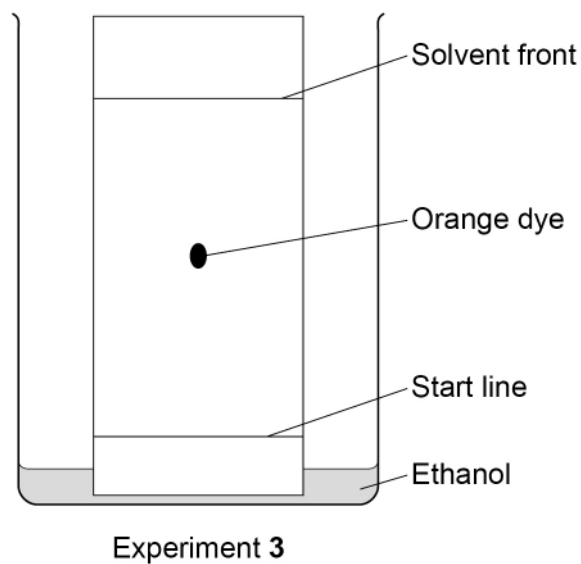

0 4 . 3 Compare the purity of the orange dyes **A** and **B**.

Give reasons for your answer.

Use **Figure 4** and **Figure 5**.

[2 marks]

---

---

---

---

0 4 . 4 The student calculated that the  $R_f$  value of the orange dye in the experiment shown in **Figure 5** was 0.48

Calculate the distance moved by the solvent front when the orange dye had moved 5.4 cm.

[3 marks]

---

---

---

---

---

Distance moved by solvent front = \_\_\_\_\_ cm

0 4 . 5 Why is the  $R_f$  value of a dye **not** affected by how far the solvent front is allowed to travel?

[1 mark]

---

---

Turn over ►



0 4 . 6

Another type of chromatography is called gas chromatography.

Gas chromatography is an instrumental method of chemical analysis.

Scientists tested the orange dyes using gas chromatography.

Suggest **two** advantages of using the instrumental method of gas chromatography rather than paper chromatography.

[2 marks]

1 \_\_\_\_\_

\_\_\_\_\_

2 \_\_\_\_\_

\_\_\_\_\_

13



**Turn over for the next question**

*Do not write  
outside the  
box*

**DO NOT WRITE ON THIS PAGE  
ANSWER IN THE SPACES PROVIDED**

**Turn over ►**



**0 5**

This question is about burning fuels in central heating boilers.

In the future, gas central heating boilers may burn hydrogen rather than natural gas.

**Table 2** shows information about these fuels when 1 dm<sup>3</sup> of the fuel is burned in a central heating boiler.

**Table 2**

	Fuel	
	Hydrogen	Natural gas
Energy released in kJ	11.9	37.1
Mass of carbon dioxide produced in grams	0.00	1.83
Mass of water vapour produced in grams	0.75	1.50
Mass of oxides of nitrogen produced in grams	$6.6 \times 10^{-4}$	$4.9 \times 10^{-4}$

**0 5 . 1**

Explain how oxides of nitrogen are produced when burning fuels.

**[2 marks]**

---

---

---

---



**0 5 . 2** Explain **one** positive impact on the environment of burning hydrogen rather than natural gas as a fuel.

Use **Table 2**.

**[2 marks]**

---

---

---

---

**0 5 . 3** Explain **one** negative impact on the environment of burning hydrogen rather than natural gas as a fuel.

Use **Table 2**.

**[2 marks]**

---

---

---

---

**Question 5 continues on the next page**

**Turn over ►**



**0 5 . 4** Air is 20% oxygen.

Calculate the volume of air needed to provide enough oxygen to react with 3.50 dm<sup>3</sup> of hydrogen gas.

The equation for the reaction is

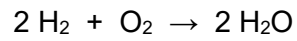

**[3 marks]**

---

---

---

---

---

Volume of air = \_\_\_\_\_ dm<sup>3</sup>

**0 5 . 5** Central heating boilers can also burn kerosene.

Kerosene is produced from crude oil in a fractionating column using fractional distillation.

In the first step, crude oil is heated and hydrocarbon vapours are formed.

Explain how kerosene is produced from these hydrocarbon vapours.

**[3 marks]**

---

---

---

---

---

---

---



**Turn over for the next question**

*Do not write  
outside the  
box*

**DO NOT WRITE ON THIS PAGE  
ANSWER IN THE SPACES PROVIDED**

**Turn over ►**



0 6

This question is about materials used to make bicycles.

**Figure 6** shows a bicycle.

**Figure 6**



**Table 3** shows information about two materials used to make bicycle frames.

**Table 3**

	Material	
	Aluminium alloy	Bamboo
Raw material	aluminium ore	bamboo plant
Cost of frame in £	250	1500
Strength in arbitrary units	290	193
Mass in kilograms	1.6	2.4
Lifespan in years	6–10	10–15
One method of disposal at end of life	recycled to make new products	burned to produce heat energy





0 6 . 3 Bicycle chains are made from an alloy of iron.

Bicycle chains rust without protection.

Paint is **not** used to protect bicycle chains from rusting.

Suggest how bicycle chains can be protected from rusting.

[1 mark]

---

---

0 6 . 4 Bicycle frames can also be made from a composite of carbon fibres embedded in a polymer resin.

What description is given in this composite to:

- the carbon fibre component
- the polymer resin component?

[2 marks]

Carbon fibre \_\_\_\_\_

Polymer resin \_\_\_\_\_

11



**Turn over for the next question**

*Do not write  
outside the  
box*

**DO NOT WRITE ON THIS PAGE  
ANSWER IN THE SPACES PROVIDED**

**Turn over ►**



0 7

This question is about sulfuric acid.

0 7 . 1

Sulfuric acid contains sulfate ions.

Describe the test for the presence of sulfate ions in sulfuric acid.

Give the result of the test.

**[2 marks]**

Test \_\_\_\_\_

\_\_\_\_\_

Result \_\_\_\_\_

\_\_\_\_\_

One stage in the industrial production of sulfuric acid is the reaction of sulfur dioxide with oxygen to produce sulfur trioxide.

This reversible reaction reaches dynamic equilibrium.

**Figure 7** shows the percentage yield of sulfur trioxide in this reaction at different temperatures.

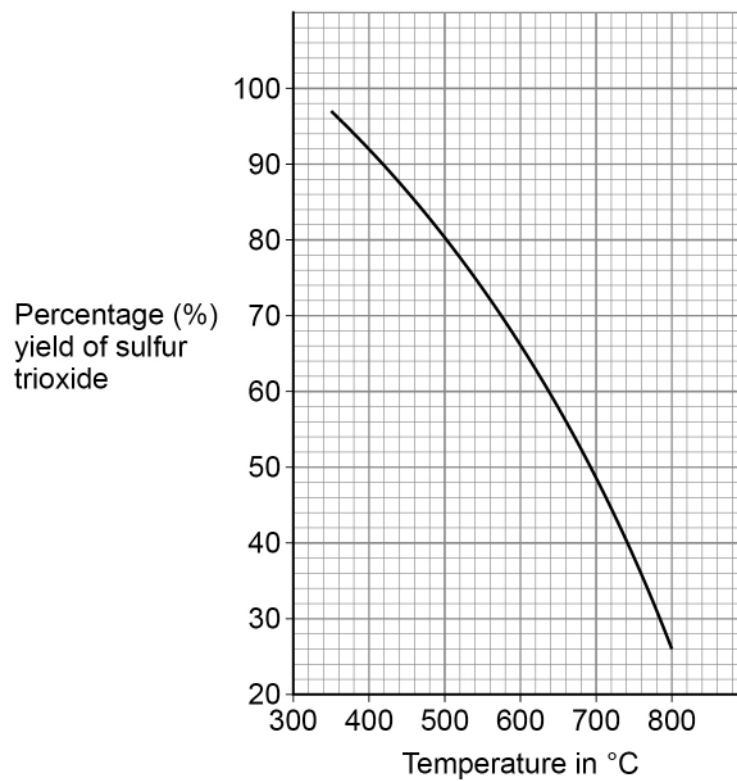
**Figure 7**

**0 7 . 2** Which statement about the forward reaction is correct?

Use **Figure 7**.

Tick (✓) **one** box.

**[1 mark]**

The yield is greater at higher temperatures because the reaction is exothermic.

The yield is greater at higher temperatures because the reaction is endothermic.

The yield is smaller at higher temperatures because the reaction is exothermic.

The yield is smaller at higher temperatures because the reaction is endothermic.

The equation for the reaction is:

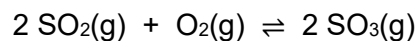

**0 7 . 3** Explain why the percentage yield of sulfur trioxide in this reaction is greater if the pressure is higher.

**[2 marks]**

---



---



---



---

**0 7 . 4** In industry, the reaction is done at 450 °C and atmospheric pressure.

Under these conditions the yield of sulfur trioxide is 86%.

Suggest **two** reasons why a higher pressure is **not** used.

**[2 marks]**

1 \_\_\_\_\_

---

2 \_\_\_\_\_

---

Turn over ►



0 7 . 5 This reaction uses a catalyst to increase the rate of the reaction.

The catalyst is a metal oxide.

Which is the most likely metal in the metal oxide catalyst?

Use the periodic table.

[1 mark]

Tick (✓) **one** box.

Aluminium (Al)

Barium (Ba)

Potassium (K)

Vanadium (V)

8



**0 8**

This question is about monomers and polymers.

Compound **A** has an alkene functional group and an ester functional group.

**Figure 8** represents a molecule of compound **A**.

**Figure 8**

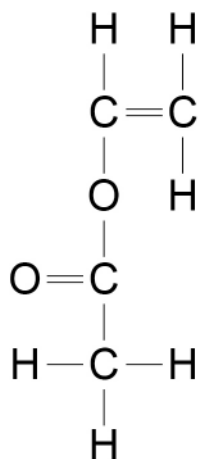
**0 8 . 1**

Draw a circle around the alkene functional group on **Figure 8**.

[1 mark]

**0 8 . 2**

Describe what will be seen when compound **A** is shaken with bromine water.

[2 marks]

---



---



---



---

**Question 8 continues on the next page**

**Turn over ►**



0 8 . 3 Figure 9 is a repeat of Figure 8.

Figure 9

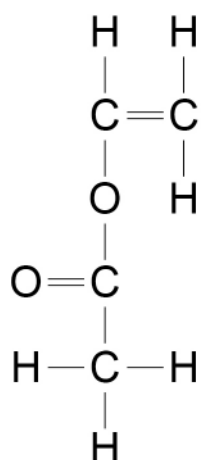

Draw a circle around the ester functional group on **Figure 9**.

[1 mark]

0 8 . 4 Compound **A** has the formula  $\text{C}_4\text{H}_6\text{O}_2$

Compound **A** is flammable.

Write a balanced equation for the complete combustion of compound **A**.

[3 marks]

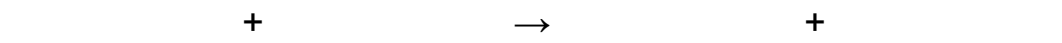

**0 8 . 5** Many molecules of compound **A** join together to form polymer **B**.

Complete the displayed formula equation which represents this reaction.

**[2 marks]**

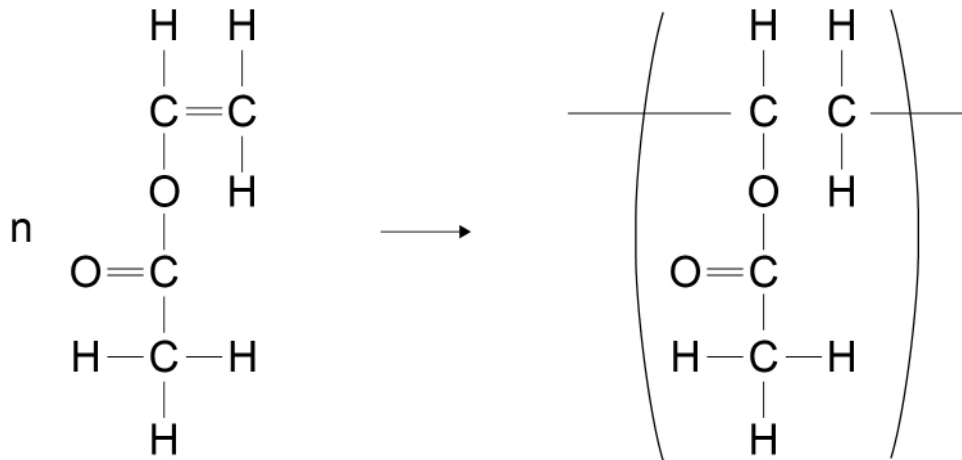

**0 8 . 6** What type of polymer is polymer **B**?

**[1 mark]**

Tick (✓) **one** box.

Addition polymer

Condensation polymer

DNA

Protein

**Question 8 continues on the next page**

**Turn over ►**



Polymer **B** is a polymer which melts when heated.

0 8 . 7

What word is used to describe polymers which melt when heated?

[1 mark]

---

0 8 . 8

Explain why some polymers do **not** melt when heated.

[2 marks]

---

---

---

---

13



**Turn over for the next question**

*Do not write  
outside the  
box*

**DO NOT WRITE ON THIS PAGE  
ANSWER IN THE SPACES PROVIDED**

**Turn over ►**



0 9

A student investigated the rate of the reaction between zinc and sulfuric acid.

The equation for the reaction is

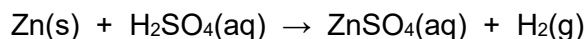
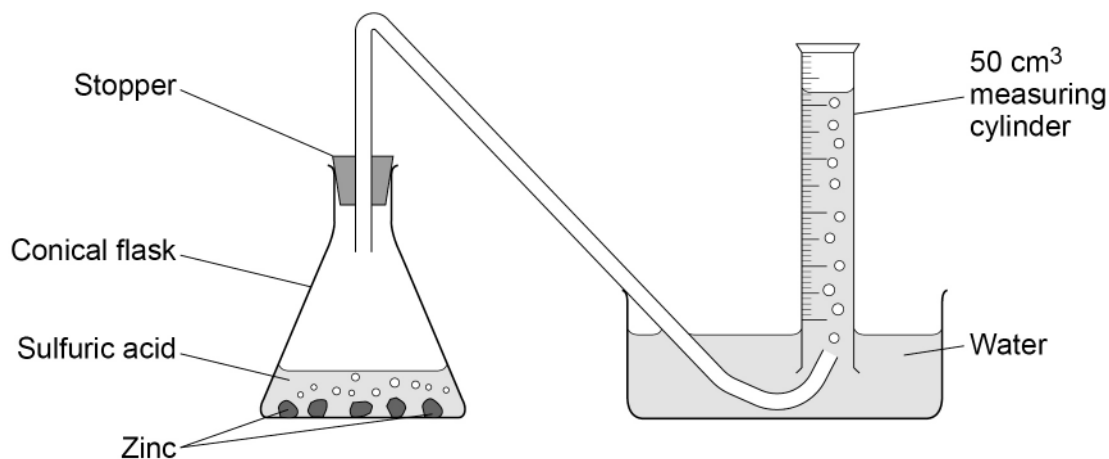

Figure 10 shows the apparatus.

Figure 10



This is the method used.

1. Pour 50 cm<sup>3</sup> of sulfuric acid into the conical flask.
2. Add excess zinc to the conical flask.
3. Insert the stopper and start a timer.
4. Measure the volume of hydrogen collected in the 50 cm<sup>3</sup> measuring cylinder every 20 seconds for 180 seconds.

0 9 . 1

Explain why the volume of hydrogen collected in the 50 cm<sup>3</sup> measuring cylinder is less than the volume of hydrogen produced.

[2 marks]

---



---



---



---



**Figure 11** shows the volumes of hydrogen collected in the 50 cm<sup>3</sup> measuring cylinder after 40 seconds and after 100 seconds.

**Figure 11**

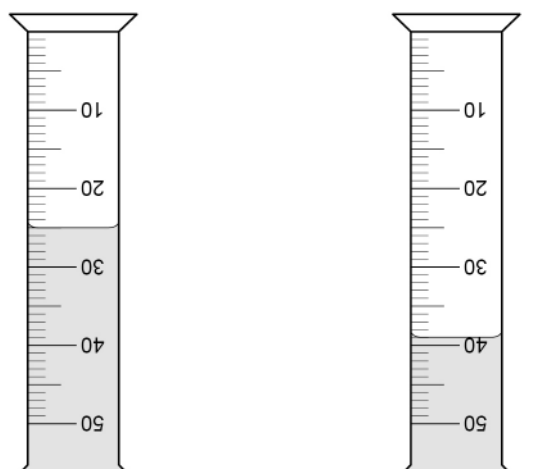

40 seconds

100 seconds

0 9 . 2

Determine the number of moles of hydrogen collected between 40 seconds and 100 seconds.

The volume of one mole of any gas at room temperature and pressure is 24 dm<sup>3</sup>.

**[4 marks]**

---



---



---



---



---



---



---



---

Moles of hydrogen = \_\_\_\_\_

**Question 9 continues on the next page**

**Turn over ►**



A different student investigated how the concentration of sulfuric acid affected the rate of the reaction.

0 9 . 3

The student did a different experiment using sulfuric acid of concentration  $0.40 \text{ mol/dm}^3$ .

The student calculated the number of moles of hydrogen collected after every 20 seconds.

Figure 12 shows the results.

Figure 12

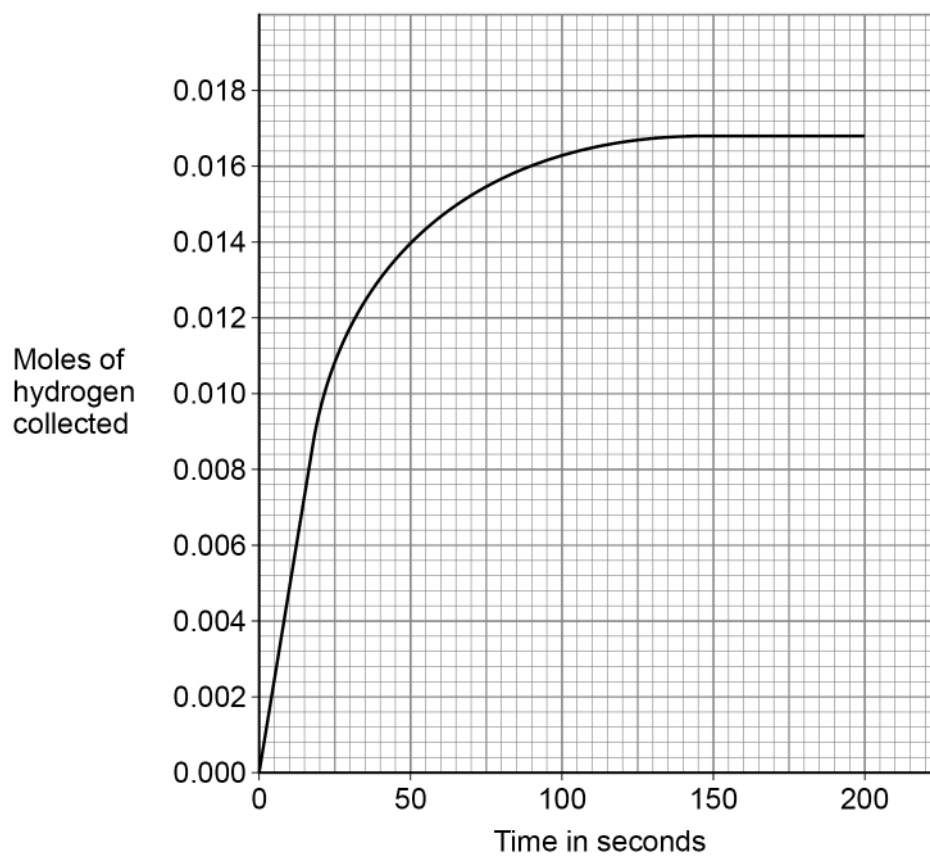

Determine the rate of reaction at 45 seconds.

You should draw a tangent on **Figure 12**.

Give your answer in standard form.

**[5 marks]**

---

---

---

---

---

---

---

---

Rate of reaction (in standard form) = \_\_\_\_\_ mol/s

**Question 9 continues on the next page**

**Turn over ►**



**0 9 . 4** Figure 13 shows the results for  $0.40 \text{ mol/dm}^3$  sulfuric acid.

**Figure 13**

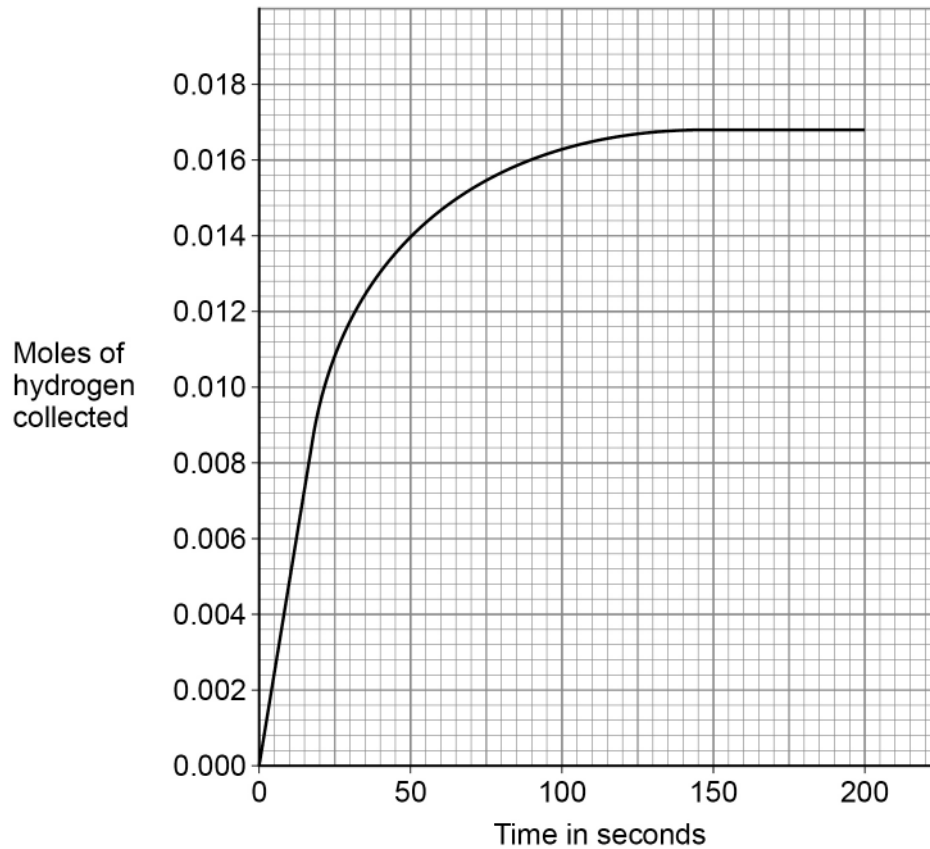

The student repeated the experiment using  $0.20 \text{ mol/dm}^3$  sulfuric acid instead of  $0.40 \text{ mol/dm}^3$  sulfuric acid.

Excess zinc was used in each experiment.

Sketch a line on **Figure 13** to show the results you would expect.

**[2 marks]**



0 9 . 5

Explain how increasing the temperature would affect the rate of reaction between zinc and sulfuric acid.

**[3 marks]**

---

---

---

---

---

---

---

---

**16****END OF QUESTIONS**

**There are no questions printed on this page**

*Do not write  
outside the  
box*

**DO NOT WRITE ON THIS PAGE  
ANSWER IN THE SPACES PROVIDED**









**There are no questions printed on this page**

*Do not write  
outside the  
box*

**DO NOT WRITE ON THIS PAGE  
ANSWER IN THE SPACES PROVIDED**

**Copyright information**

For confidentiality purposes, all acknowledgements of third-party copyright material are published in a separate booklet. This booklet is published after each live examination series and is available for free download from [www.aqa.org.uk](http://www.aqa.org.uk).

Permission to reproduce all copyright material has been applied for. In some cases, efforts to contact copyright-holders may have been unsuccessful and AQA will be happy to rectify any omissions of acknowledgements. If you have any queries please contact the Copyright Team.

Copyright © 2024 AQA and its licensors. All rights reserved.

