

Please check the examination details below before entering your candidate information

Candidate surname

Other names

Centre Number

Candidate Number

Pearson Edexcel Level 3 GCE

Wednesday 15 May 2024

Morning (Time: 1 hour 30 minutes)

Paper
reference

8PH0/01

Physics

Advanced Subsidiary

PAPER 1: Core Physics I

You must have:

Scientific calculator and ruler

Data, Formulae and Relationships Booklet (enclosed)

Total Marks

Instructions

- Use **black** ink or ball-point pen.
- If pencil is used for diagrams/sketches/graphs it must be dark (HB or B).
- **Fill in the boxes** at the top of this page with your name, centre number and candidate number.
- Answer **all** questions in Sections A and B.
- Answer the questions in the spaces provided
– *there may be more space than you need.*

Information

- The total mark for this paper is 80.
- The marks for **each** question are shown in brackets
– *use this as a guide as to how much time to spend on each question.*
- In the question marked with an **asterisk** (*), marks will be awarded for your ability to structure your answer logically, showing how the points that you make are related or follow on from each other where appropriate.

Advice

- Read each question carefully before you start to answer it.
- Try to answer every question.
- Check your answers if you have time at the end.
- You are advised to show your working in calculations including units where appropriate.

Turn over ►

P74476RA

©2024 Pearson Education Ltd.
E:1/1/1/1/1



Pearson

SECTION A

Answer ALL questions.

All multiple choice questions must be answered with a cross in the box for the correct answer from A to D. If you change your mind about an answer, put a line through the box and then mark your new answer with a cross .

1 Which of the following quantities is a scalar quantity?

- A energy
- B moment of a force
- C momentum
- D velocity

(Total for Question 1 = 1 mark)

2 Two ice skaters, P and Q, are close together and stationary on an ice rink. P pushes Q and they move away from each other.

The mass of P is greater than the mass of Q.

Assume the frictional force between the ice and the skates is negligible.

Which of the following statements is correct?

- A P and Q both move at the same speed.
- B P and Q have the same magnitude of momentum.
- C P has a greater magnitude of momentum than Q.
- D P moves faster than Q.

(Total for Question 2 = 1 mark)

DO NOT WRITE IN THIS AREA

DO NOT WRITE IN THIS AREA

DO NOT WRITE IN THIS AREA



DO NOT WRITE IN THIS AREA

DO NOT WRITE IN THIS AREA

DO NOT WRITE IN THIS AREA

3 A ball is thrown and follows the path shown.

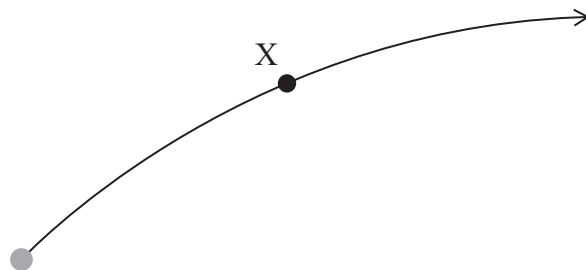

Air resistance is negligible.

Which of the following is a free-body force diagram for the ball at position X?



A



B

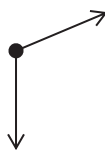

C

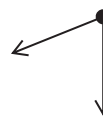

D

- A
- B
- C
- D

(Total for Question 3 = 1 mark)



4 The circuit shown contains a cell with internal resistance.

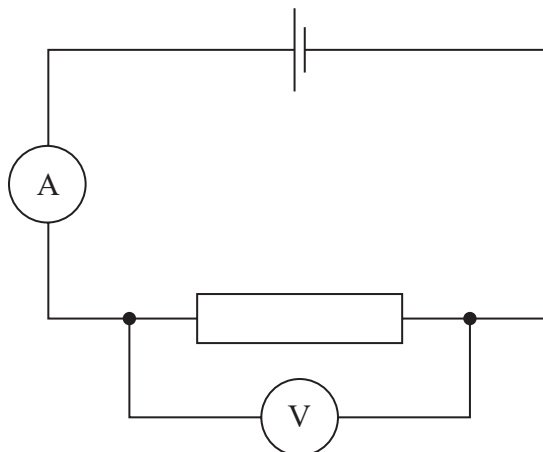

The cell is replaced with another cell, with the same e.m.f. but greater internal resistance.

Which row of the table shows what happens to the ammeter reading and voltmeter reading?

	Ammeter reading	Voltmeter reading
<input type="checkbox"/> A	increases	increases
<input type="checkbox"/> B	increases	decreases
<input type="checkbox"/> C	decreases	increases
<input type="checkbox"/> D	decreases	decreases

(Total for Question 4 = 1 mark)



DO NOT WRITE IN THIS AREA

DO NOT WRITE IN THIS AREA

DO NOT WRITE IN THIS AREA

5 A copper wire has a cross-sectional area A and length l . There is a potential difference V across the wire. The resistance of the wire is R .

Copper has n conduction electrons per unit volume.

Which of the following expressions gives the drift velocity of the electrons along the wire?

A $\frac{RnAe}{V}$

B $\frac{R}{VnAe}$

C $\frac{V}{RnAe}$

D $\frac{VnAe}{R}$

(Total for Question 5 = 1 mark)



- 6 A ball rolls along a table of height 0.83 m. The ball has a horizontal velocity of 1.72 ms^{-1} as it falls off the edge of the table.

Which of the following is an expression for the speed of the ball, in ms^{-1} , as it hits the floor?

- A $\sqrt{(2 \times 9.81 \times 0.83)^2 + 1.72^2}$
- B $(2 \times 9.81 \times 0.83)^2 + 1.72^2$
- C $\sqrt{(2 \times 9.81 \times 0.83) + 1.72^2}$
- D $(2 \times 9.81 \times 0.83) + 1.72^2$

(Total for Question 6 = 1 mark)

- 7 Which of the following units is equivalent to the joule?

- A Ns
- B kgms^{-2}
- C Ws
- D kgms^{-1}

(Total for Question 7 = 1 mark)



DO NOT WRITE IN THIS AREA

DO NOT WRITE IN THIS AREA

DO NOT WRITE IN THIS AREA

8 A simplified velocity-time graph for the flight of a drone is shown.

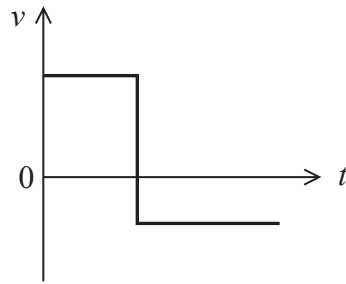

Which of the following is a displacement-time graph for the same flight?

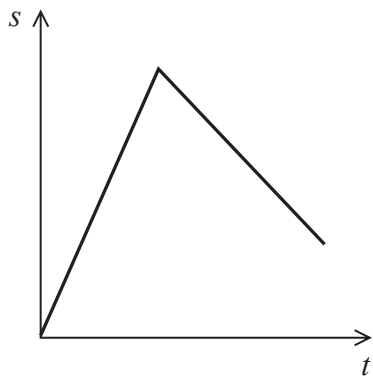

A

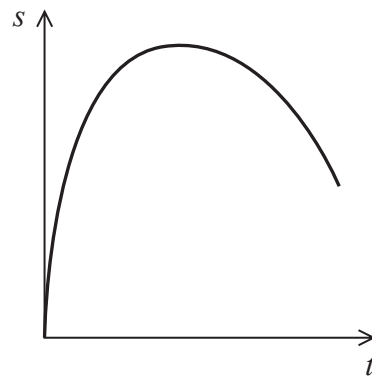

B

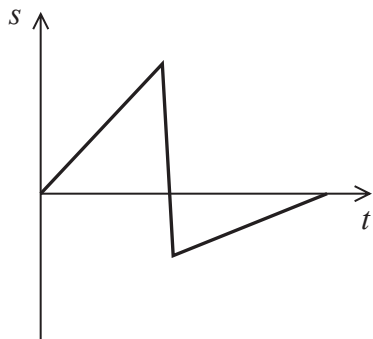

C

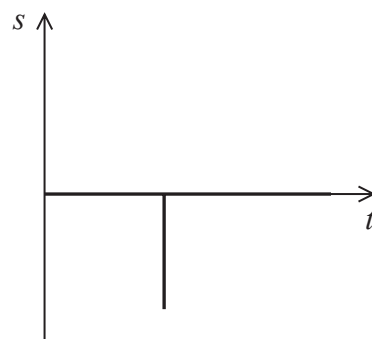

D

- A
- B
- C
- D

(Total for Question 8 = 1 mark)



P 7 4 4 7 6 R A 0 7 3 2

9 A windsurfer stands on a windsurf board and holds onto the sail, as shown.

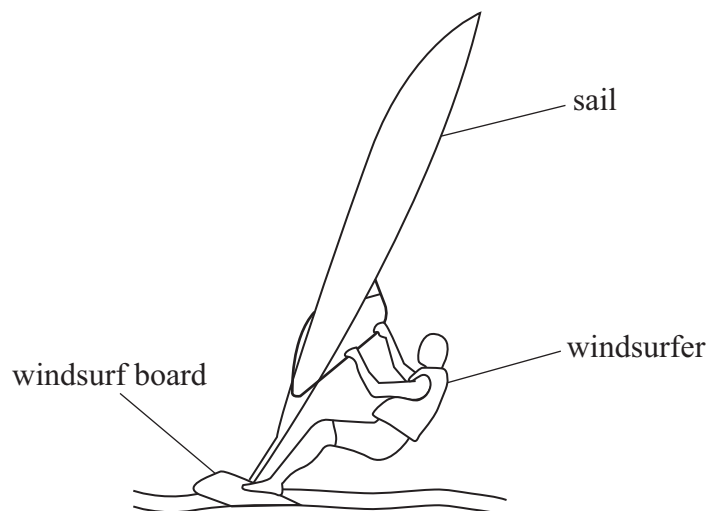

As the force from the wind increases, the windsurfer leans back further.

Explain how leaning back further keeps the windsurfer in equilibrium. Your explanation should make reference to moments.

.....

.....

.....

.....

.....

.....

(Total for Question 9 = 3 marks)



DO NOT WRITE IN THIS AREA

DO NOT WRITE IN THIS AREA

DO NOT WRITE IN THIS AREA

10 A coin is given a push and moves across a table.

- (a) The coin moves 65 cm before coming to rest. There is a mean resistive force of $2.2 \times 10^{-3} \text{ N}$ on the coin as it moves.

Calculate the initial speed of the coin.

mass of coin = 8.5 g

(3)

.....

.....

.....

.....

.....

.....

.....

Initial speed =

- (b) The coin is pushed again, but with a larger force. The coin moves beyond the edge of the table and falls to the floor through a vertical height of 1.2 m.

The speed of the coin as it reaches the edge of the table is 0.40 m s^{-1} .

Calculate the horizontal distance travelled by the coin as it falls to the floor.

(3)

.....

.....

.....

.....

.....

.....

.....

Horizontal distance travelled by coin =

(Total for Question 10 = 6 marks)



11 The picture shows a toy car. There is an inflated balloon attached to the car. As the balloon deflates, air is released from the back of the car and the car starts to move.

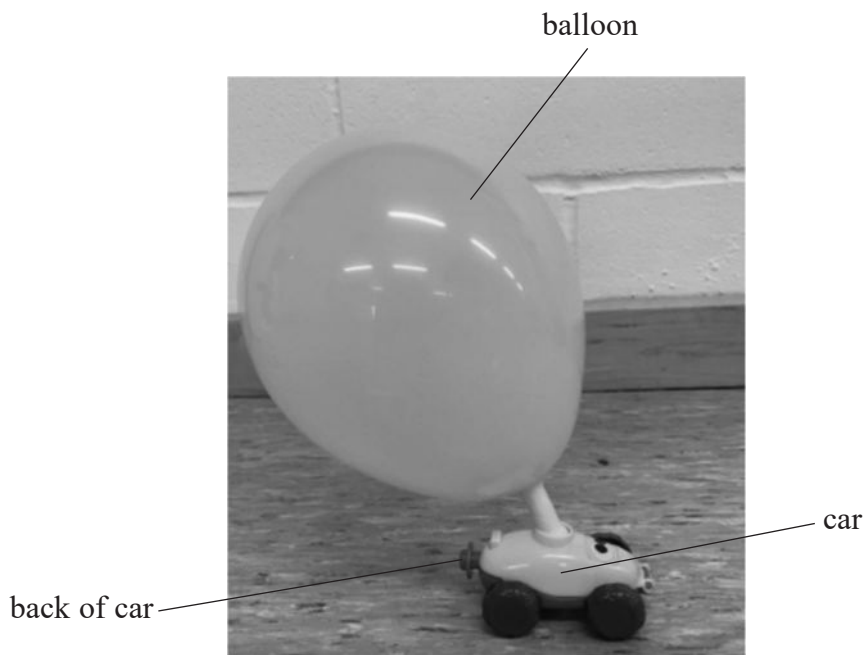

Explain, with reference to Newton's laws of motion, how the release of the air from the back of the car causes the car to start to move.

.....

.....

.....

.....

.....

.....

.....

.....

.....

.....

(Total for Question 11 = 4 marks)

DO NOT WRITE IN THIS AREA

DO NOT WRITE IN THIS AREA

DO NOT WRITE IN THIS AREA



DO NOT WRITE IN THIS AREA

DO NOT WRITE IN THIS AREA

DO NOT WRITE IN THIS AREA

- 12 A student carried out an experiment to determine the resistivity of a metal alloy. The student used a wire made of the alloy and connected it in a circuit, as shown.

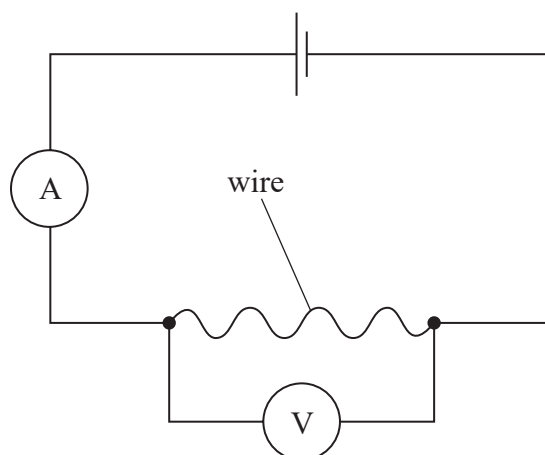

- (a) Describe how the student could have measured the diameter of the wire accurately.

(2)

.....

.....

.....

.....

(b) The student made the following measurements:

- voltmeter reading = 1.96 V
- ammeter reading = 0.57 A
- diameter of wire = 0.58 mm
- length of wire = 83.5 cm

Calculate the resistivity of the metal alloy.

(4)

.....

.....

.....

.....

.....

.....

.....

.....

.....

.....

Resistivity =

(c) The student stated that the ammeter reading was the most significant source of uncertainty in the calculated value of resistivity.

- The percentage uncertainty in the ammeter reading was 0.9%.
- The percentage uncertainty in the measurement of diameter was 0.8%.
- The percentage uncertainty in the measurement of length was 0.1%.
- The percentage uncertainty in the voltmeter reading was 0.3%.

Assess the validity of the student's statement.

(3)

.....

.....

.....

.....

.....

.....

.....

.....

.....

.....

(Total for Question 12 = 9 marks)



DO NOT WRITE IN THIS AREA

DO NOT WRITE IN THIS AREA

DO NOT WRITE IN THIS AREA

13 The diagram shows a car being driven down a slope at a constant speed.

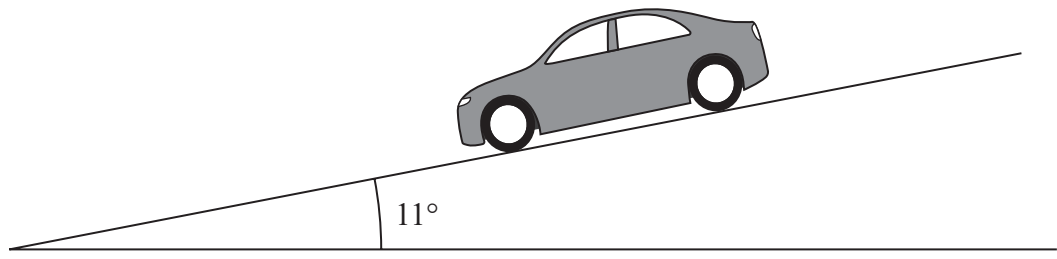

(a) (i) Complete the free-body force diagram for the car. (3)



(ii) The total resistive force acting on the car is 2530 N.
Calculate the driving force required for the car to maintain a constant speed.
weight of car = 1.2×10^4 N (3)

.....
.....
.....
.....
.....

Driving force =



- (b) A very steep road may have a lane to the side, filled with deep gravel. A vehicle with brake failure can drive onto the lane and will be brought to rest as the vehicle's wheels sink into the gravel.

The graph shows the decrease in velocity of a van as it comes to rest in the gravel.

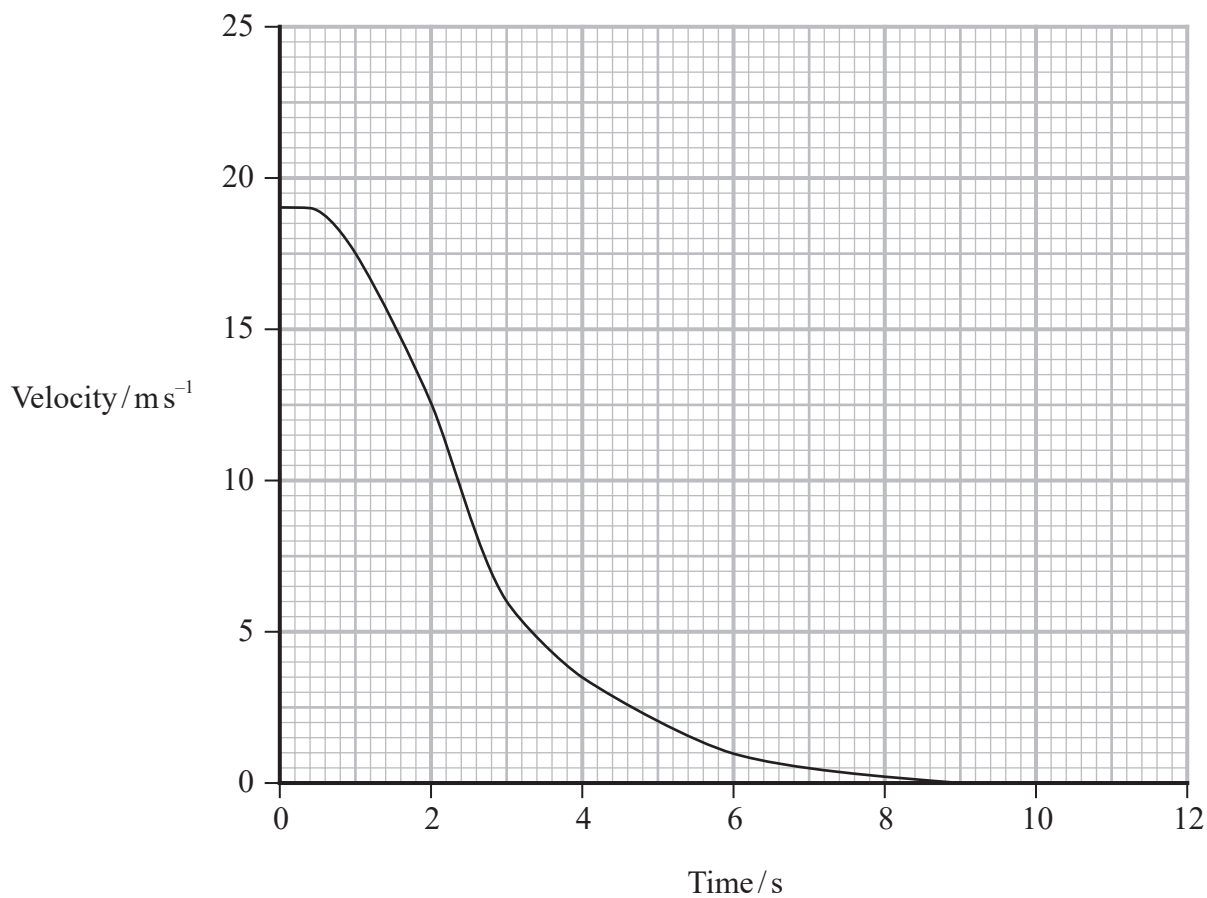

(i) Calculate the maximum decelerating force on the van.

mass of van = 2400 kg

(4)

.....

.....

.....

.....

.....

.....

.....

.....

.....

Maximum decelerating force = N

(ii) Describe the energy transfers taking place as a vehicle comes to rest in the gravel.

(1)

.....

.....

(Total for Question 13 = 11 marks)

DO NOT WRITE IN THIS AREA

DO NOT WRITE IN THIS AREA

DO NOT WRITE IN THIS AREA



- 14 A light emitting diode (LED) is placed in a circuit with a fixed resistor and a variable power supply. An ammeter and a high resistance voltmeter are also connected, as shown.

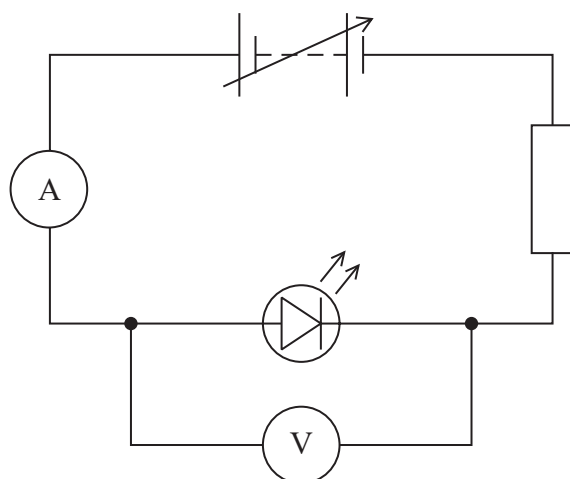

The graph shows how the current I through the LED varies with the potential difference V_{LED} across the LED.

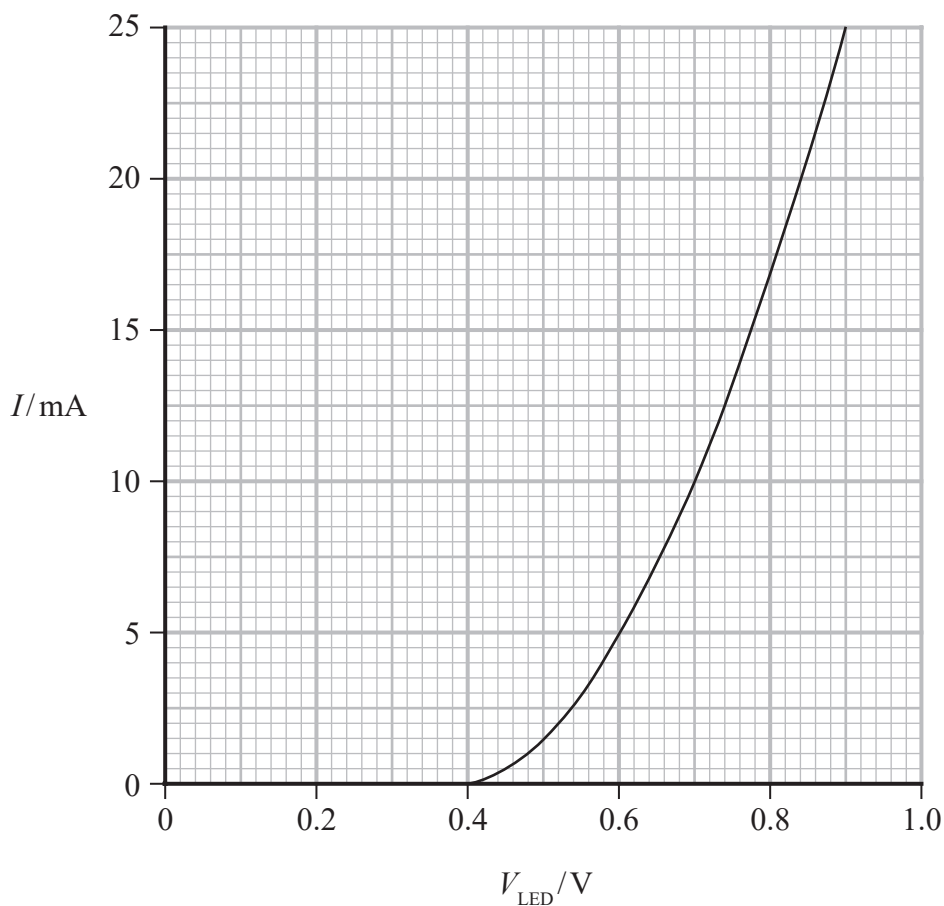

DO NOT WRITE IN THIS AREA

DO NOT WRITE IN THIS AREA

DO NOT WRITE IN THIS AREA



DO NOT WRITE IN THIS AREA

DO NOT WRITE IN THIS AREA

DO NOT WRITE IN THIS AREA

(a) When the potential difference across the variable power supply is 6.0 V, the ammeter reading is 12.5 mA.

Calculate the resistance of the fixed resistor.

(4)

.....

.....

.....

.....

.....

.....

.....

Resistance =



*(b) The ammeter and voltmeter were removed from the circuit.

The variable power supply was replaced by a signal generator and an oscilloscope, as shown.

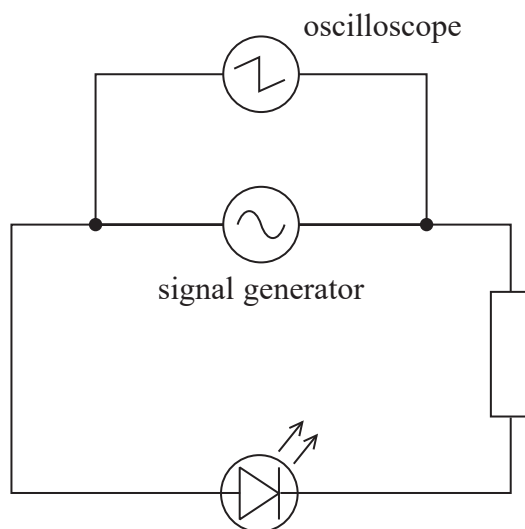

The output from the signal generator is shown on the oscilloscope screen below.

The output varies between +6V and -6V.

Points A, B and C represent instants of time.

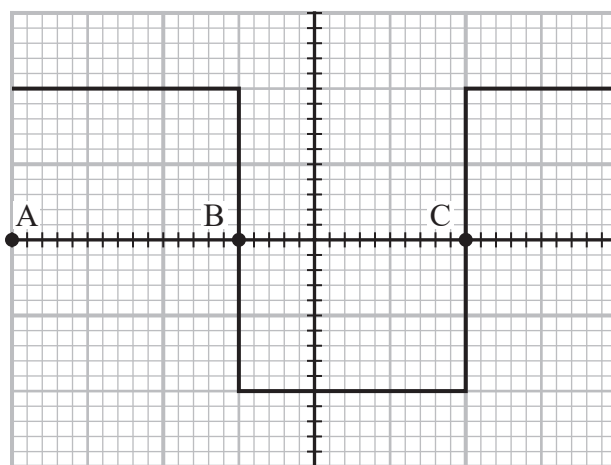

Explain why the LED flashes. Your answer should refer to the output between times A and C.

(6)

DO NOT WRITE IN THIS AREA

DO NOT WRITE IN THIS AREA

DO NOT WRITE IN THIS AREA

(Total for Question 14 = 10 marks)



P 7 4 4 7 6 R A 0 1 9 3 2

15 Electric cars are powered by a large battery within the car.

- (a) The manufacturer of an electric car states that the battery stores a maximum charge of 110Ah.

The graph shows how the current through the battery varies with time as the battery is charged.

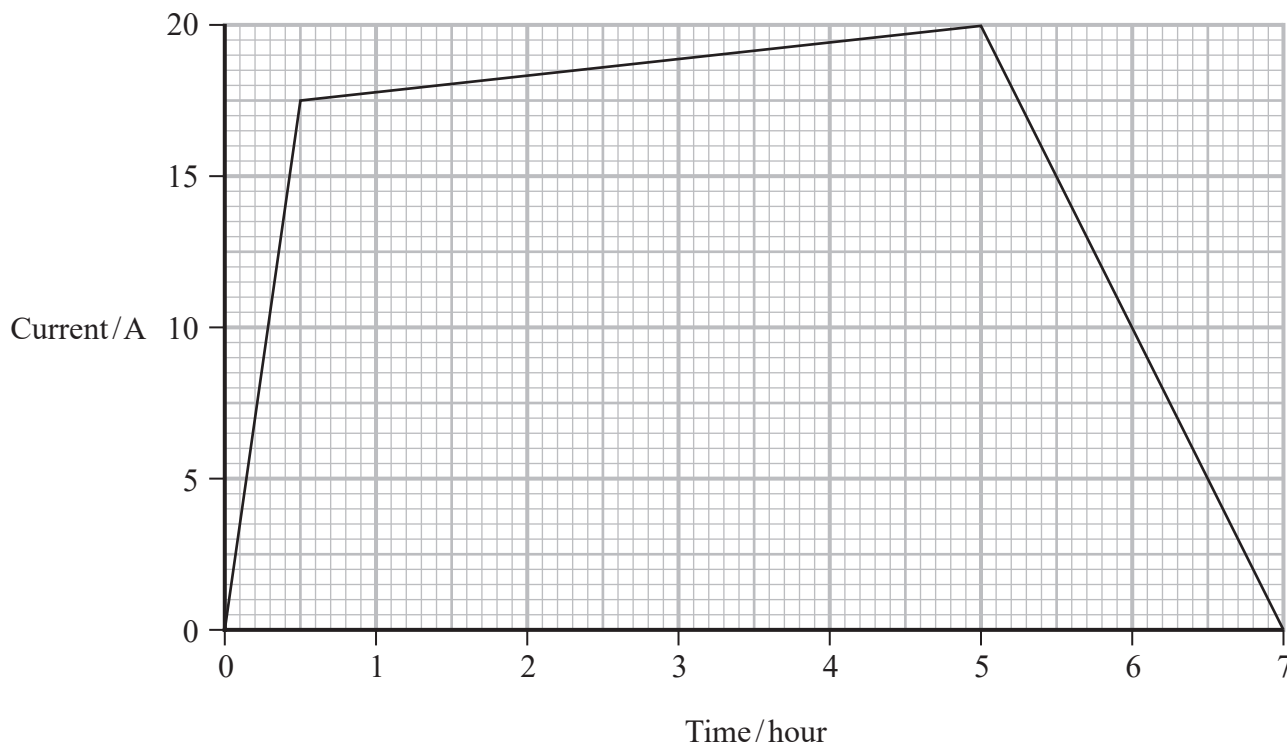

The manufacturer claims that it takes 5 hours to reach 90% of the maximum charge.

Criticise this statement.

(3)

.....

.....

.....

.....

.....

.....



DO NOT WRITE IN THIS AREA

DO NOT WRITE IN THIS AREA

DO NOT WRITE IN THIS AREA

(b) The manufacturer tested the car by driving it at constant speed along a horizontal track. The manufacturer determined that the maximum range of the car was 160 km.

(i) Show that the average value for the resistive forces on the car was about 800 N.

efficiency of car = 85%

energy stored when battery has maximum charge = 42 kWh

(3)

.....

.....

.....

.....

.....

.....

(ii) The manufacturer repeated the test on a sloping track, as shown. This reduced the maximum range of the car. At the new maximum range, the car had moved upwards through a vertical height of 3.0 km.



Calculate the reduction in the maximum range of the car.

mass of car = 1300 kg

(3)

.....

.....

.....

.....

.....

.....

Reduction in maximum range =

(Total for Question 15 = 9 marks)

TOTAL FOR SECTION A = 60 MARKS



P 7 4 4 7 6 R A 0 2 1 3 2

DO NOT WRITE IN THIS AREA

DO NOT WRITE IN THIS AREA

DO NOT WRITE IN THIS AREA

BLANK PAGE



SECTION B

Answer ALL questions in the spaces provided.

16 A spring was hung from a clamp, as shown.

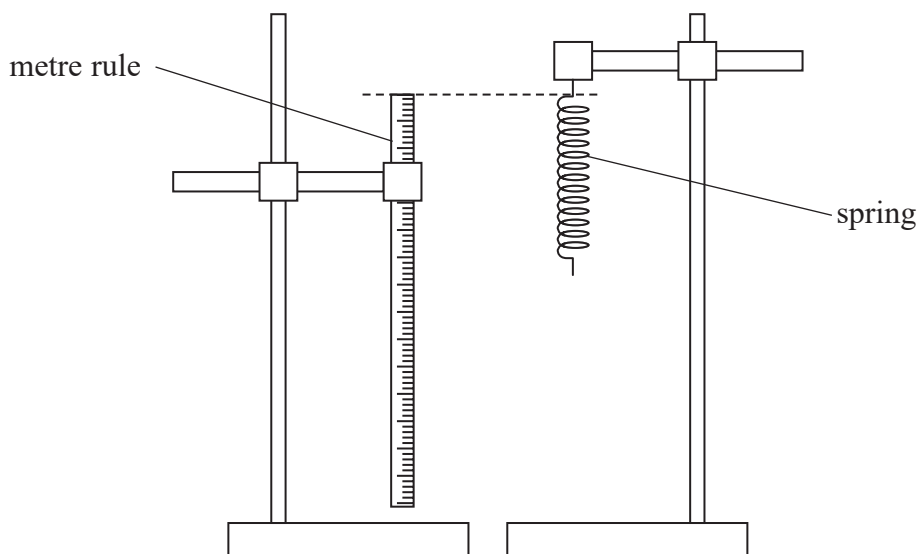

(a) A student used the metre rule to measure the unstretched length of the spring.

Describe how the student could make this measurement as accurate as possible.

(2)

.....

.....

.....

.....

DO NOT WRITE IN THIS AREA

DO NOT WRITE IN THIS AREA

DO NOT WRITE IN THIS AREA



P 7 4 4 7 6 R A 0 2 3 3 2

- (b) The student used the spring to investigate the forces on a uniform rod. One end of the rod was attached to a pivot and the other end was supported by the spring. The distance between the pivot and the spring stayed constant.

A weight was attached to the rod at a distance d from the pivot, as shown. The stretched length of the spring was l .

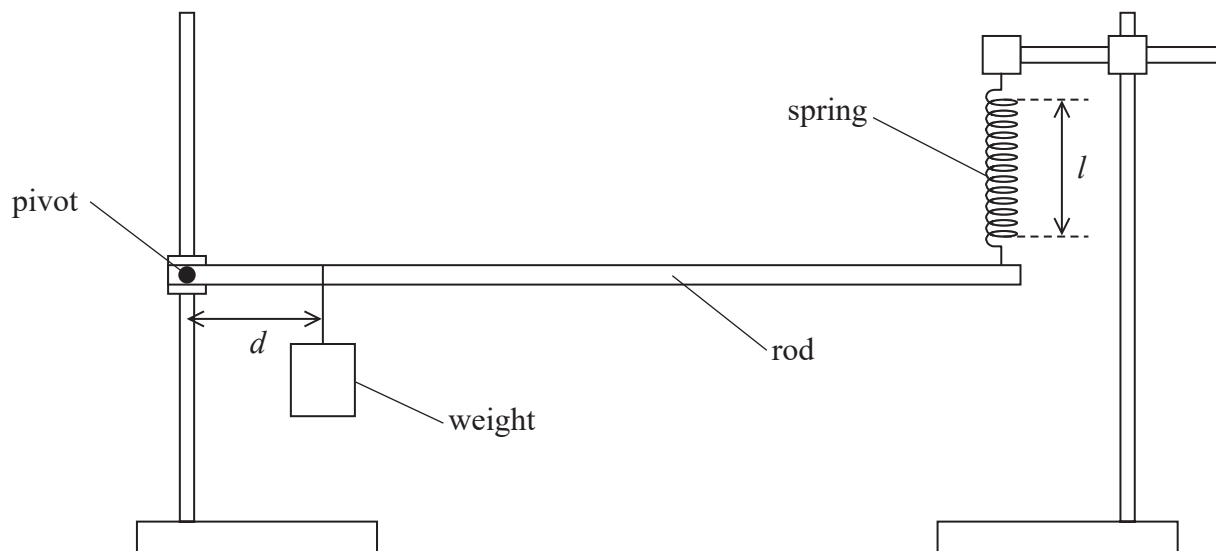

The student changed the position of the weight to vary d and measured corresponding values of l . The results are recorded below.

d/cm	l/cm	
10.0	6.6	
20.0	8.4	
30.0	10.9	
40.0	13.0	
50.0	15.3	
60.0	17.3	

- (i) Plot a graph of the extension Δl of the spring on the y -axis against d on the x -axis on the grid opposite. Use the additional column of the table for your processed data.

unstretched length of spring = 3.5 cm

(5)



DO NOT WRITE IN THIS AREA

DO NOT WRITE IN THIS AREA

DO NOT WRITE IN THIS AREA

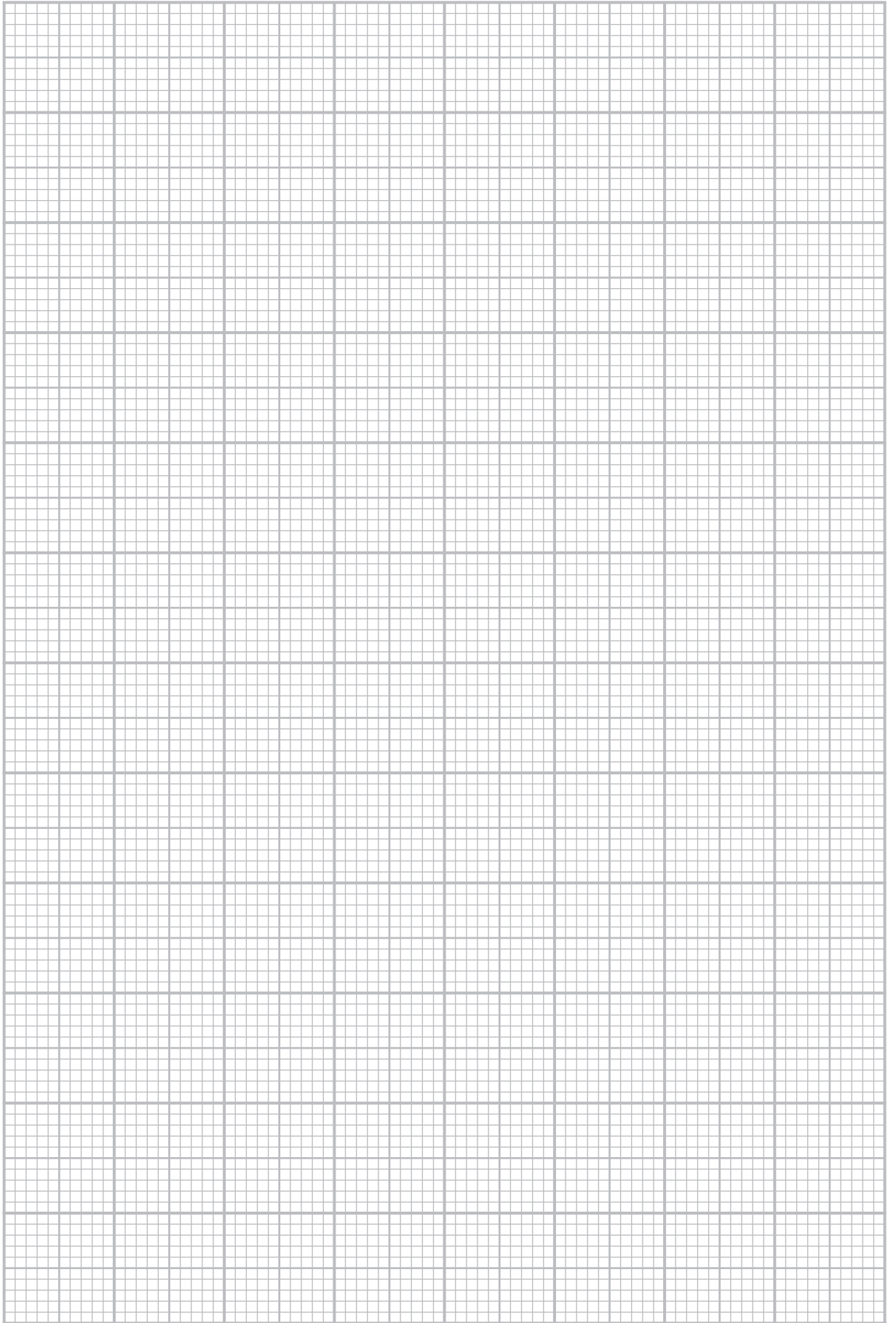

P 7 4 4 7 6 R A 0 2 5 3 2

(ii) The student was given the following relationship

$$\Delta l = \frac{Wd}{kD} + C$$

where C is a constant

D is the distance from the pivot to the spring = 0.875 m

W is the weight on the rod = 5.00 N

Determine the spring constant k using data from the graph.

(4)

$k =$

(Total for Question 16 = 11 marks)

DO NOT WRITE IN THIS AREA

DO NOT WRITE IN THIS AREA

DO NOT WRITE IN THIS AREA



DO NOT WRITE IN THIS AREA

DO NOT WRITE IN THIS AREA

DO NOT WRITE IN THIS AREA

BLANK PAGE



17 A washing line is attached to two posts which are a distance 5.94 m apart. A wet blanket of width 2.20 m is hung from the centre of the washing line. The washing line stretches to a length of 6.06 m and hangs at an angle θ , as shown.

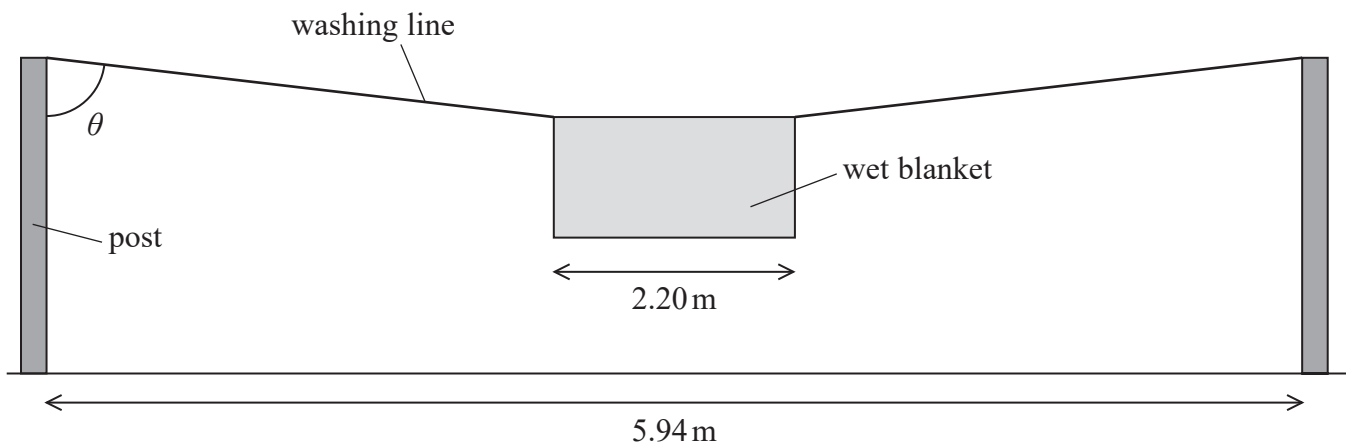

(a) Calculate the tension in the washing line.

mass of wet blanket = 9.36 kg

(4)

Tension =



DO NOT WRITE IN THIS AREA

DO NOT WRITE IN THIS AREA

DO NOT WRITE IN THIS AREA

(b) Explain what happens to the height of the blanket from the ground as the blanket dries. Your answer should make reference to the Young modulus of the material of the line.

(5)

.....

.....

.....

.....

.....

.....

.....

.....

.....

.....

.....

.....

.....

.....

.....

.....

.....

.....

.....

.....

.....

.....

.....

(Total for Question 17 = 9 marks)

TOTAL FOR SECTION B = 20 MARKS
TOTAL FOR PAPER = 80 MARKS



DO NOT WRITE IN THIS AREA

DO NOT WRITE IN THIS AREA

DO NOT WRITE IN THIS AREA

BLANK PAGE



DO NOT WRITE IN THIS AREA

DO NOT WRITE IN THIS AREA

DO NOT WRITE IN THIS AREA

BLANK PAGE



P 7 4 4 7 6 R A 0 3 1 3 2

DO NOT WRITE IN THIS AREA

DO NOT WRITE IN THIS AREA

DO NOT WRITE IN THIS AREA

BLANK PAGE



Pearson Edexcel Level 3 GCE

Wednesday 15 May 2024

Morning (Time: 1 hour 30 minutes)

Paper
reference

8PH0/01

Physics

Advanced Subsidiary

PAPER 1: Core Physics I

Data, Formulae and Relationships Booklet

Do not return this Booklet with the question paper.

Turn over ►

P74476RA

©2024 Pearson Education Ltd.
F:1/1/1/1/1/



P 7 4 4 7 6 R A

Pearson

List of data, formulae and relationships

Acceleration of free fall	$g = 9.81 \text{ m s}^{-2}$	(close to Earth's surface)
Electron charge	$e = -1.60 \times 10^{-19} \text{ C}$	
Electron mass	$m_e = 9.11 \times 10^{-31} \text{ kg}$	
Electronvolt	$1 \text{ eV} = 1.60 \times 10^{-19} \text{ J}$	
Gravitational field strength	$g = 9.81 \text{ N kg}^{-1}$	(close to Earth's surface)
Planck constant	$h = 6.63 \times 10^{-34} \text{ J s}$	
Speed of light in a vacuum	$c = 3.00 \times 10^8 \text{ m s}^{-1}$	

Mechanics

Kinematic equations of motion

$$s = \frac{(u + v)t}{2}$$

$$v = u + at$$

$$s = ut + \frac{1}{2}at^2$$

$$v^2 = u^2 + 2as$$

Forces

$$\Sigma F = ma$$

$$g = \frac{F}{m}$$

$$W = mg$$

$$\text{moment of force} = Fx$$

Momentum

$$p = mv$$

Work, energy and power

$$\Delta W = F\Delta s$$

$$E_k = \frac{1}{2}mv^2$$

$$\Delta E_{\text{grav}} = mg\Delta h$$

$$P = \frac{E}{t}$$

$$P = \frac{W}{t}$$

$$\text{efficiency} = \frac{\text{useful energy output}}{\text{total energy input}}$$

$$\text{efficiency} = \frac{\text{useful power output}}{\text{total power input}}$$

Electricity

Potential difference

$$V = \frac{W}{Q}$$

Resistance

$$R = \frac{V}{I}$$

Electrical power and energy

$$P = VI$$

$$P = I^2R$$

$$P = \frac{V^2}{R}$$

$$W = VI t$$

Resistivity

$$R = \frac{\rho l}{A}$$

Current

$$I = \frac{\Delta Q}{\Delta t}$$

$$I = nqvA$$



Materials

Density

$$\rho = \frac{m}{V}$$

Stokes' law

$$F = 6\pi\eta r v$$

Hooke's law

$$\Delta F = k\Delta x$$

Young modulus

$$\text{Stress } \sigma = \frac{F}{A}$$

$$\text{Strain } \varepsilon = \frac{\Delta x}{x}$$

$$E = \frac{\sigma}{\varepsilon}$$

Elastic strain energy

$$\Delta E_{\text{el}} = \frac{1}{2}F\Delta x$$

Waves and particle nature of light

Wave speed

$$v = f\lambda$$

Speed of a transverse wave on a string

$$v = \sqrt{\frac{T}{\mu}}$$

Intensity of radiation

$$I = \frac{P}{A}$$

Power of a lens

$$P = \frac{1}{f}$$

$$P = P_1 + P_2 + P_3 + \dots$$

Thin lens equation

$$\frac{1}{u} + \frac{1}{v} = \frac{1}{f}$$

Magnification for a lens

$$m = \frac{\text{image height}}{\text{object height}} = \frac{v}{u}$$

Diffraction grating

$$n\lambda = d \sin \theta$$

Refractive index

$$n_1 \sin \theta_1 = n_2 \sin \theta_2$$

$$n = \frac{c}{v}$$

Critical angle

$$\sin C = \frac{1}{n}$$

Photon model

$$E = hf$$

Einstein's photoelectric equation

$$hf = \phi + \frac{1}{2}mv_{\text{max}}^2$$

de Broglie wavelength

$$\lambda = \frac{h}{p}$$

END OF DATA, FORMULAE AND RELATIONSHIPS LIST



BLANK PAGE

