

Please check the examination details below before entering your candidate information

Candidate surname

Other names

Centre Number

Candidate Number

--	--	--	--	--

--	--	--	--	--

Pearson Edexcel Level 1/Level 2 GCSE (9–1)

Friday 14 June 2024

Afternoon (Time: 1 hour 10 minutes)

**Paper
reference**

1SC0/2PF

**Combined Science
PAPER 6**

Foundation Tier

You must have:

Calculator, ruler, Equation Booklet (enclosed)

Total Marks

Instructions

- Use **black** ink or ball-point pen.
- **Fill in the boxes** at the top of this page with your name, centre number and candidate number.
- Answer **all** questions.
- Answer the questions in the spaces provided – *there may be more space than you need.*
- Calculators may be used.
- Any diagrams may NOT be accurately drawn, unless otherwise indicated.
- You must **show all your working out** with **your answer clearly identified** at the end of your solution.

Information

- The total mark for this paper is 60.
- The marks for **each** question are shown in brackets – *use this as a guide as to how much time to spend on each question.*
- In questions marked with an **asterisk** (*), marks will be awarded for your ability to structure your answer logically, showing how the points that you make are related or follow on from each other where appropriate.

Advice

- Read each question carefully before you start to answer it.
- Try to answer every question.
- Check your answers if you have time at the end.

Turn over ►

P74482A

©2024 Pearson Education Ltd.
F:1/



Pearson

Answer ALL questions. Write your answers in the spaces provided.

Some questions must be answered with a cross in a box ☒. If you change your mind about an answer, put a line through the box ☒ and then mark your new answer with a cross ☒.

1 (a) Figure 1 shows a circuit containing a battery and **four** other components.

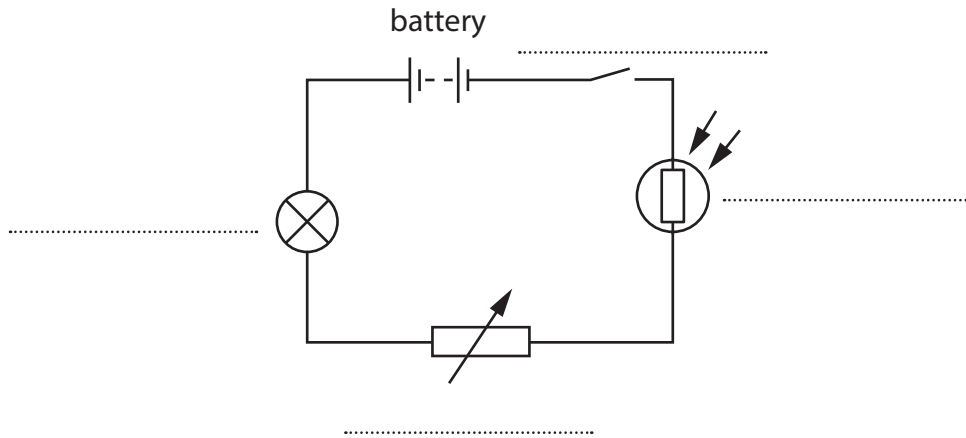

Figure 1

Label the **four** components in Figure 1, using words from the box.

ammeter	lamp	LDR
switch	thermistor	variable resistor

(4)

(b) The circuit in Figure 1 is switched on.

A charge of 1.2 C leaves the battery in a time of 4.0 s.

Calculate the current in the circuit.

Use the equation

$$\text{current} = \frac{\text{charge}}{\text{time}} \quad (2)$$

current = A

(Total for Question 1 = 6 marks)



DO NOT WRITE IN THIS AREA

DO NOT WRITE IN THIS AREA

DO NOT WRITE IN THIS AREA

2 (a) Figure 2 shows the shape of the magnetic field lines around a bar magnet.

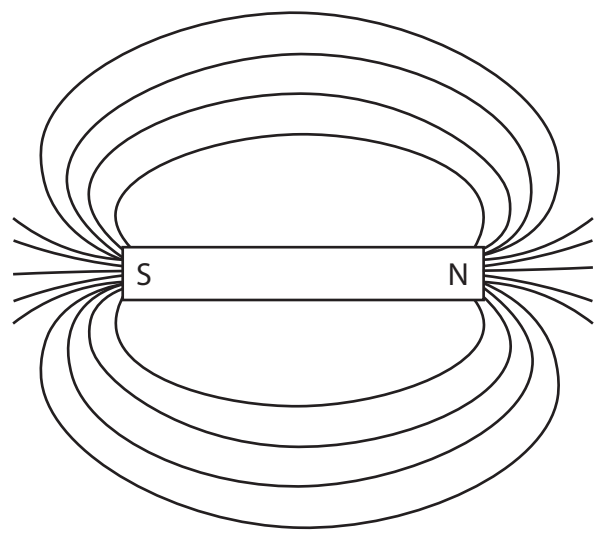

Figure 2

- (i) Draw **one** arrow on a magnetic field line in Figure 2 to show the direction of that magnetic field line. (1)
- (ii) Draw an **X** on Figure 2 to show where the magnetic field is strongest. (1)
- (iii) Give a reason why Figure 2 shows the magnetic field is strongest at point **X**. (1)

.....
.....



(b) A student places two magnets on a smooth bench.

The student holds the magnets close to each other, as shown in Figure 3.



Figure 3

(i) Draw some magnetic field lines on Figure 3 to show the shape of the magnetic field **between** the two magnets.

(2)

(ii) The student is holding the two magnets on the smooth bench.

State what would happen if the student let go of one of the magnets.

(1)

(c) A student is given two permanent magnets and some paper clips, as shown in Figure 4.

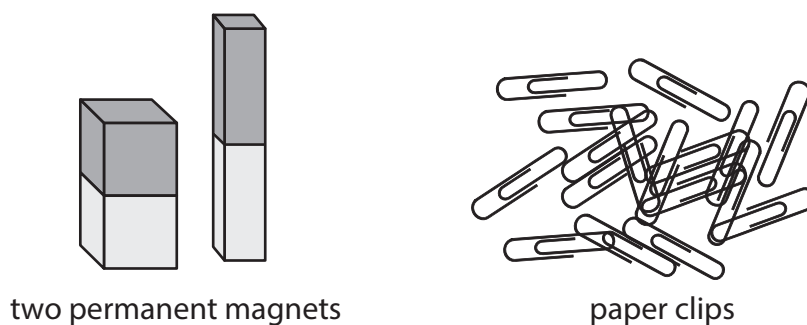

two permanent magnets

paper clips

Figure 4

The paper clips are **not** magnets, but they are made from a magnetic material.

(i) Which of these is a magnetic material?

(1)

- A** aluminium
- B** iron
- C** plastic
- D** wood



(ii) Describe how the student could use the paper clips to find out which of the two permanent magnets is the stronger magnet.

(2)

.....

.....

.....

.....

.....

(Total for Question 2 = 9 marks)

DO NOT WRITE IN THIS AREA

DO NOT WRITE IN THIS AREA

DO NOT WRITE IN THIS AREA



3 (a) Figure 5 shows a truck on a horizontal road.

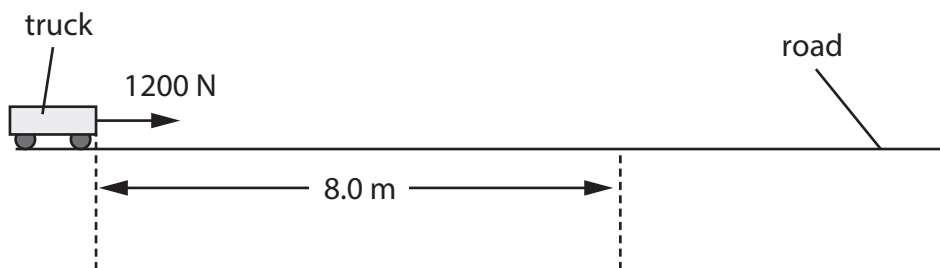

Figure 5

(i) A force of 1200 N pulls the truck along the road for a distance of 8.0 m.

Calculate the work done by the 1200 N force.

Use the equation

$$\text{work done} = \text{force} \times \text{distance moved in the direction of the force}$$

State the unit of work done.

(3)

work done =

unit

(ii) At 8.0 m the force is removed and the truck slows down until it stops.

Describe the energy transfers as the truck slows down.

(2)

.....

.....

.....

.....



(b) A box has a mass of 90 kg.

Which of these is the weight of the box?

(1)

- A 9 N
- B 90 N
- C 900 N
- D 9000 N

(c) Figure 6 shows a truck lifting a different box.

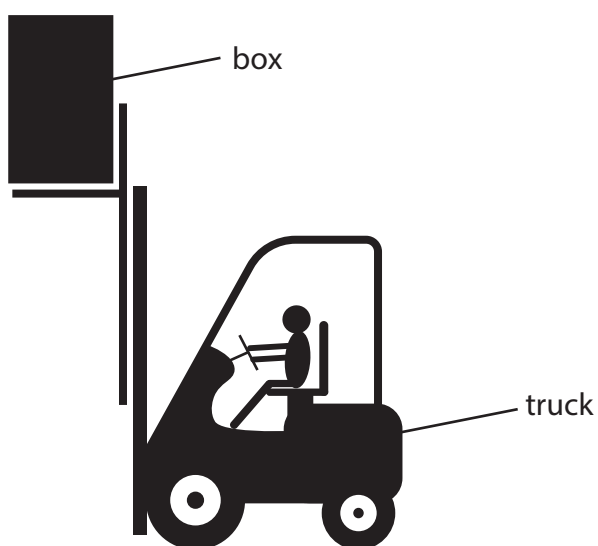

Figure 6

A student calculates the change in gravitational potential energy, ΔGPE , for the box at different heights.

DO NOT WRITE IN THIS AREA

DO NOT WRITE IN THIS AREA

DO NOT WRITE IN THIS AREA



P 7 4 4 8 2 A 0 7 2 4

Figure 7 shows the results of the student's calculations.

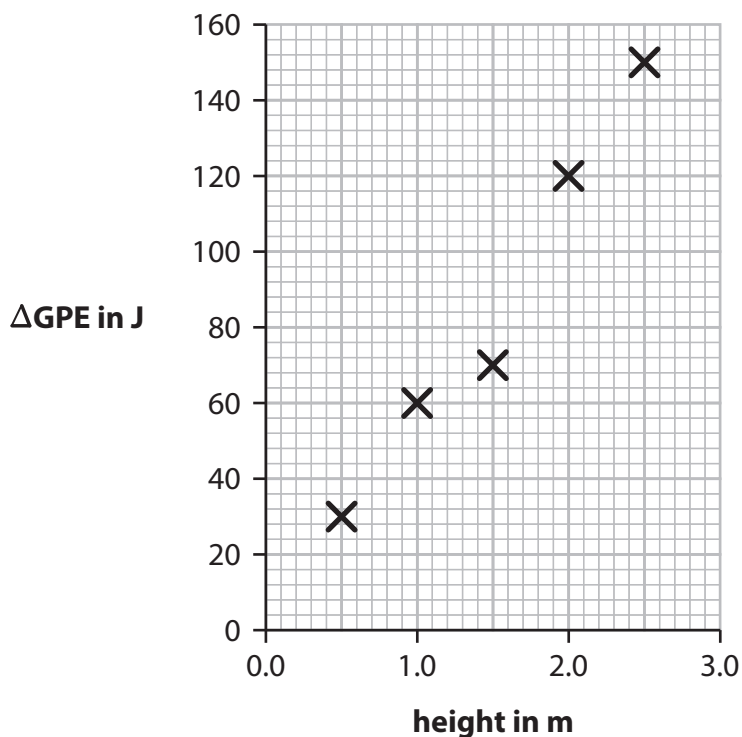

Figure 7

- (i) The student has made one incorrect calculation.

On Figure 7, draw a circle round the **X** for this incorrect calculation.

(1)

- (ii) The truck lifts the box from the ground to a height of 2.0 m.

This takes a time of 5.0 s.

Using data from the graph in Figure 7, calculate the power needed to lift the box.

(3)

Use the equation

$$\text{power} = \frac{\Delta GPE}{\text{time}}$$

power = W

(Total for Question 3 = 10 marks)



DO NOT WRITE IN THIS AREA

DO NOT WRITE IN THIS AREA

DO NOT WRITE IN THIS AREA

4 Figure 8 shows a saucepan of milk being heated on an electric cooker.



© Por Fabian Ponce Garcia/Shutterstock

Figure 8

(a) Figure 9 is a table of data about the milk being heated.

mass of milk	0.82 kg
starting temperature of milk	10 °C
final temperature of milk	40 °C
change in thermal energy of milk	96 000 J

Figure 9

(i) Using data from the table in Figure 9, calculate the increase in temperature of the milk.

(1)

increase in temperature = °C

(ii) Using data from the table in Figure 9, calculate the specific heat capacity of the milk.

Use the equation

$$\text{specific heat capacity} = \frac{\text{change in thermal energy}}{\text{mass} \times \text{increase in temperature}} \quad (2)$$

specific heat capacity = J/kg °C



P 7 4 4 8 2 A 0 9 2 4

(b) The cooker supplies 130 000 J of energy in a time of 87 s.

(i) Calculate the power supplied by the cooker.

Use the equation

$$P = \frac{E}{t}$$

Give your answer to 2 significant figures.

(3)

power = W

(ii) The cooker supplies 130 000 J of energy but only 96 000 J of this energy is used to heat the milk.

Calculate the efficiency of heating the milk using this cooker.

Use the equation

$$\text{efficiency} = \frac{\text{useful energy transferred}}{\text{total energy supplied}}$$

(2)

efficiency =



DO NOT WRITE IN THIS AREA

DO NOT WRITE IN THIS AREA

DO NOT WRITE IN THIS AREA

BLANK PAGE



DO NOT WRITE IN THIS AREA

DO NOT WRITE IN THIS AREA

DO NOT WRITE IN THIS AREA

5 (a) Figure 10 is a circuit diagram.

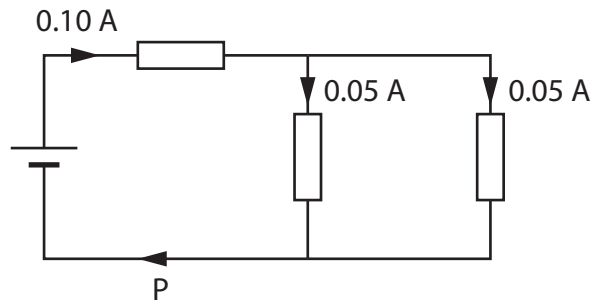

Figure 10

The current at P is

(1)

- A** 0.05 A
- B** 0.10 A
- C** 0.15 A
- D** 0.20 A



P 7 4 4 8 2 A 0 1 3 2 4

(b) Some students investigate resistors in parallel.

The students set up a circuit containing **four** identical resistors.

The circuit used is shown in Figure 11.

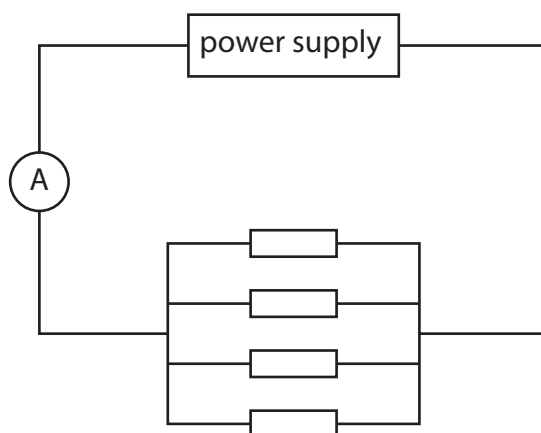

Figure 11

The students measure the current from the power supply and the voltage (p.d.) across the resistors.

- (i) On Figure 11, draw a voltmeter connected to measure the voltage (p.d.) across the resistors.

(1)

The students remove one resistor and measure the current and voltage again with only 3 resistors in the circuit.

They repeat the measurements of current and voltage with only 2 resistors in the circuit and then with only 1 resistor in the circuit.

Figure 12 is a table of their results.

number of resistors	current in mA	voltage in V
4		6.00
3	27.3	6.00
2	18.2	6.00
1	9.1	6.00

Figure 12



(ii) Using data from the table in Figure 12, predict the current from the power supply when there are 4 resistors in the circuit. (1)

current = mA

(iii) Using data from the table in Figure 12, calculate the resistance of **only 1** resistor. (3)

resistance = Ω

(iv) Using data from the table in Figure 12, explain what happens to the **total resistance of the circuit** as the number of resistors in parallel decreases. (3)

.....

.....

.....

.....

.....

.....

.....



DO NOT WRITE IN THIS AREA

DO NOT WRITE IN THIS AREA

DO NOT WRITE IN THIS AREA

(c) An electric fire is connected to a 230 V mains supply.

A current of 9.0 A is supplied to the fire.

Calculate the power supplied to the fire.

Use the equation

$$\text{power} = \text{current} \times \text{voltage}$$

(2)

power = W

(Total for Question 5 = 11 marks)



DO NOT WRITE IN THIS AREA

DO NOT WRITE IN THIS AREA

DO NOT WRITE IN THIS AREA

BLANK PAGE



P 7 4 4 8 2 A 0 1 7 2 4

6 (a) A coil of copper wire has a mass of 14.1 g.

The density, ρ , of copper is 8.96 g/cm^3 .

Calculate the volume of the copper wire.

Use the equation

$$\rho = \frac{m}{V} \quad (3)$$

volume = cm^3

DO NOT WRITE IN THIS AREA

DO NOT WRITE IN THIS AREA

DO NOT WRITE IN THIS AREA



DO NOT WRITE IN THIS AREA

DO NOT WRITE IN THIS AREA

DO NOT WRITE IN THIS AREA

(b) Figure 13 gives information about the density of aluminium.

	density in g/cm ³
solid aluminium	2.70
liquid aluminium	2.38

Figure 13

Explain the difference between the density of solid aluminium and the density of liquid aluminium in terms of the arrangement of particles.

(2)

.....

.....

.....

.....

(c) A student boils some water.

Calculate the amount of thermal energy needed to change 60.0 g of water to steam at its boiling point.

The specific latent heat of vaporisation of water, L , is 2.26×10^6 J/kg.

Use the equation

$$Q = m \times L$$

(2)

amount of thermal energy = J



*(d) A student is investigating the melting of ice.

The student has some crushed ice in a beaker at a temperature of -20°C .

The student heats the beaker and its contents for 20 minutes.

Figure 14 is a graph of the student's results.

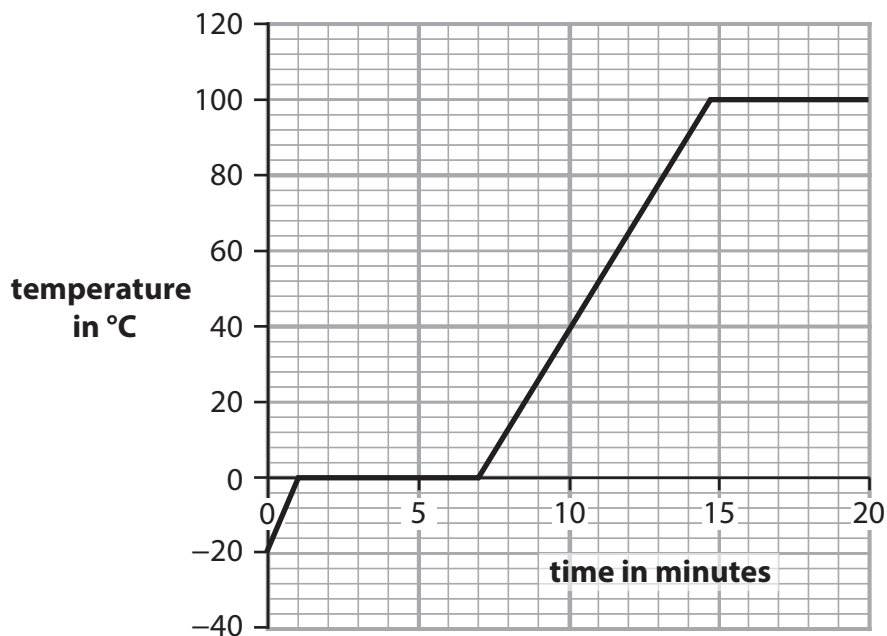

Figure 14

Using information from the graph, describe the changes that take place in the 20 minutes shown on the graph.

Your answer should refer to

- data from the graph
- the state (solid, liquid or gas) of the contents of the beaker.

(6)

Answer lines for this question start on page 21



DO NOT WRITE IN THIS AREA

DO NOT WRITE IN THIS AREA

DO NOT WRITE IN THIS AREA

Handwriting practice area with 20 horizontal dotted lines.

(Total for Question 6 = 13 marks)

TOTAL FOR PAPER = 60 MARKS



DO NOT WRITE IN THIS AREA

DO NOT WRITE IN THIS AREA

DO NOT WRITE IN THIS AREA

BLANK PAGE



DO NOT WRITE IN THIS AREA

DO NOT WRITE IN THIS AREA

DO NOT WRITE IN THIS AREA

BLANK PAGE



P 7 4 4 8 2 A 0 2 3 2 4

DO NOT WRITE IN THIS AREA

DO NOT WRITE IN THIS AREA

DO NOT WRITE IN THIS AREA

BLANK PAGE



Pearson Edexcel Level 1/Level 2 GCSE (9–1)

Friday 14 June 2024

Paper
reference

1SC0/2PF

Combined Science

PAPER 6

Foundation Tier

Equation Booklet

Do not return this Booklet with the question paper.

Turn over ►

P74482A

©2024 Pearson Education Ltd.
F:1/



P 7 4 4 8 2 A



Pearson

If you're taking **GCSE (9–1) Combined Science** or **GCSE (9–1) Physics**, you will need these equations:

HT = higher tier

distance travelled = average speed × time	
acceleration = change in velocity ÷ time taken	$a = \frac{(v-u)}{t}$
force = mass × acceleration	$F = m \times a$
weight = mass × gravitational field strength	$W = m \times g$
HT momentum = mass × velocity	$p = m \times v$
change in gravitational potential energy = mass × gravitational field strength × change in vertical height	$\Delta GPE = m \times g \times \Delta h$
kinetic energy = $\frac{1}{2} \times \text{mass} \times (\text{speed})^2$	$KE = \frac{1}{2} \times m \times v^2$
efficiency = $\frac{(\text{useful energy transferred by the device})}{(\text{total energy supplied to the device})}$	
wave speed = frequency × wavelength	$v = f \times \lambda$
wave speed = distance ÷ time	$v = \frac{x}{t}$
work done = force × distance moved in the direction of the force	$E = F \times d$
power = work done ÷ time taken	$P = \frac{E}{t}$
energy transferred = charge moved × potential difference	$E = Q \times V$
charge = current × time	$Q = I \times t$
potential difference = current × resistance	$V = I \times R$
power = energy transferred ÷ time taken	$P = \frac{E}{t}$
electrical power = current × potential difference	$P = I \times V$
electrical power = (current) ² × resistance	$P = I^2 \times R$
density = mass ÷ volume	$\rho = \frac{m}{V}$



	force exerted on a spring = spring constant \times extension	$F = k \times x$
	(final velocity) ² – (initial velocity) ² = 2 \times acceleration \times distance	$v^2 - u^2 = 2 \times a \times x$
HT	force = change in momentum \div time	$F = \frac{(mv - mu)}{t}$
	energy transferred = current \times potential difference \times time	$E = I \times V \times t$
HT	force on a conductor at right angles to a magnetic field carrying a current = magnetic flux density \times current \times length	$F = B \times I \times l$
	For transformers with 100% efficiency, potential difference across primary coil \times current in primary coil = potential difference across secondary coil \times current in secondary coil	$V_p \times I_p = V_s \times I_s$
	change in thermal energy = mass \times specific heat capacity \times change in temperature	$\Delta Q = m \times c \times \Delta\theta$
	thermal energy for a change of state = mass \times specific latent heat	$Q = m \times L$
	energy transferred in stretching = 0.5 \times spring constant \times (extension) ²	$E = \frac{1}{2} \times k \times x^2$

If you're taking **GCSE (9–1) Physics**, you also need these extra equations:

	moment of a force = force \times distance normal to the direction of the force	
	pressure = force normal to surface \div area of surface	$P = \frac{F}{A}$
HT	$\frac{\text{potential difference across primary coil}}{\text{potential difference across secondary coil}} = \frac{\text{number of turns in primary coil}}{\text{number of turns in secondary coil}}$	$\frac{V_p}{V_s} = \frac{N_p}{N_s}$
	to calculate pressure or volume for gases of fixed mass at constant temperature	$P_1 \times V_1 = P_2 \times V_2$
HT	pressure due to a column of liquid = height of column \times density of liquid \times gravitational field strength	$P = h \times \rho \times g$

END OF EQUATION LIST



BLANK PAGE

