

Answer ALL questions. Write your answers in the spaces provided.

Some questions must be answered with a cross . If you change your mind about an answer, put a line through the box and then mark your new answer with a cross .

- 1 (a) Concrete is a composite material made of cement, sand and stone.

Different types of concrete are produced by changing the ratio of cement, sand and stone.

Figure 1 shows some information about three different types of concrete, **A**, **B** and **C**.

| concrete | mixing ratio cement : sand : stone | compressive strength in kPa | example of use |
|----------|---------------------------------------|--------------------------------|----------------|
| A | 1 : 2 : 4 | 17 250 | fence posts |
| B | 1 : 2 : 3 | 27 600 | paving slabs |
| C | 1 : 2 : 2 | 31 050 | flooring |

Figure 1

- (i) State how the amount of stone added to the mixture affects the compressive strength of concrete.

(1)

- (ii) What mass of stone is in a sample of concrete **B** containing 5000 kg of sand?

(1)

- A** 2500 kg
- B** 5000 kg
- C** 7500 kg
- D** 10 000 kg



(iii) Sand contains silicon dioxide.

Figure 2 shows part of the structure of silicon dioxide.

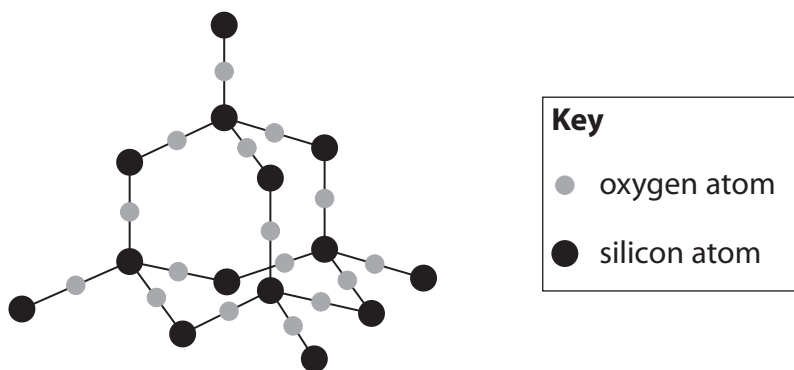

Figure 2

State the type of structure and bonding in silicon dioxide.

(1)

.....

.....

(b) (i) Which statement about nanoparticles is correct?

(1)

- A nanoparticles are smaller than atoms and molecules
- B nanoparticles are smaller than atoms but larger than molecules
- C nanoparticles are larger than atoms but smaller than molecules
- D nanoparticles are larger than atoms and molecules

(ii) Some sunscreens contain nanoparticles of titanium dioxide.

Explain why nanoparticles of titanium dioxide are used in some sunscreens.

(2)

.....

.....

.....

.....

(Total for Question 1 = 6 marks)

DO NOT WRITE IN THIS AREA

DO NOT WRITE IN THIS AREA

DO NOT WRITE IN THIS AREA



2 A student investigates the reaction between marble chips and dilute hydrochloric acid.

The student measures the total volume of carbon dioxide gas produced each minute, for 10 minutes.

(a) Figure 3 shows part of the apparatus used in the experiment.

Complete Figure 3 by drawing and labelling apparatus that could be used to collect and measure the volume of the carbon dioxide gas.

(2)

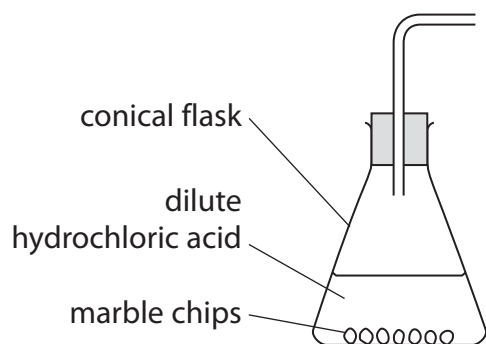

Figure 3

DO NOT WRITE IN THIS AREA

DO NOT WRITE IN THIS AREA

DO NOT WRITE IN THIS AREA



(b) Figure 4 shows a graph of the results of the experiment.

A tangent has been drawn on the curve at a time of 3.5 minutes.

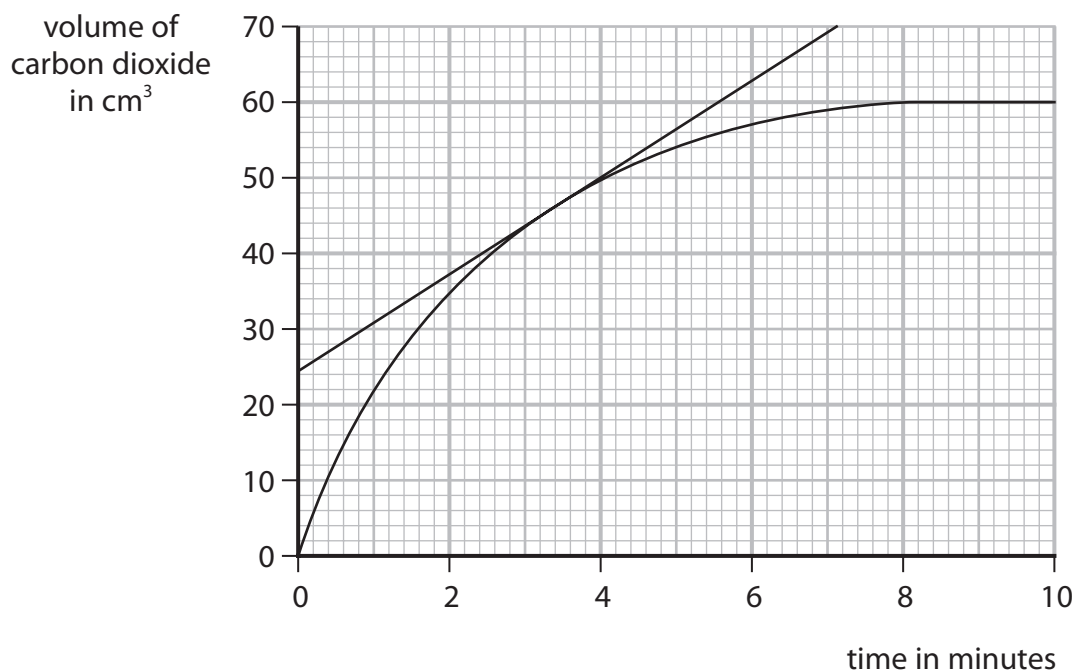

Figure 4

(i) State the total volume of carbon dioxide produced in the first 3.5 minutes.

(1)

volume = cm³

(ii) Using the tangent, calculate the rate of reaction at 3.5 minutes in cm³ per minute.

$$\text{rate of reaction} = \frac{\text{change in gas volume}}{\text{change in time}} \quad (3)$$

.....

.....

.....

.....

rate = cm³ per minute

DO NOT WRITE IN THIS AREA

DO NOT WRITE IN THIS AREA

DO NOT WRITE IN THIS AREA



P 7 4 4 2 6 A 0 5 3 2

(c) The student repeats the experiment using the same mass of smaller marble chips.

All other conditions remain the same.

Explain the effect on the rate of reaction of using smaller marble chips.

(2)

.....

.....

.....

.....

.....

(d) Which change would make the rate of reaction slower?

(1)

- A** using the same acid at a higher temperature
- B** using acid of a lower concentration
- C** using a larger flask
- D** adding a catalyst

(Total for Question 2 = 9 marks)



3 This question is about the atmosphere.

(a) Describe the test to show that a gas is oxygen.

(2)

.....

.....

.....

(b) Copper reacts with oxygen to form copper oxide.

2.100 g of copper will react completely with 0.529 g of oxygen.

In an experiment, 4.200 g of copper is heated with 50.000 g of oxygen until the reaction is complete.

Calculate the mass of oxygen remaining at the end of the experiment.

(2)

.....

.....

.....

mass of oxygen = g

(c) Helium, neon and argon are all inert.

(i) Explain, in terms of electrons, why these gases are inert.

(2)

.....

.....

.....

(ii) Two pieces of steel can be joined by heating the metal pieces with a very hot flame.

This process is often carried out in an argon atmosphere rather than in air.

Which property makes argon gas suitable for this use?

(1)

- A argon has a low density
- B argon has a low melting point
- C argon is colourless
- D argon is unreactive



(d) Carbon dioxide is removed from the atmosphere by plants and stored in plants and soil as carbon compounds.

Figure 5 shows the relative amounts of carbon stored in plants and soils in different environments.

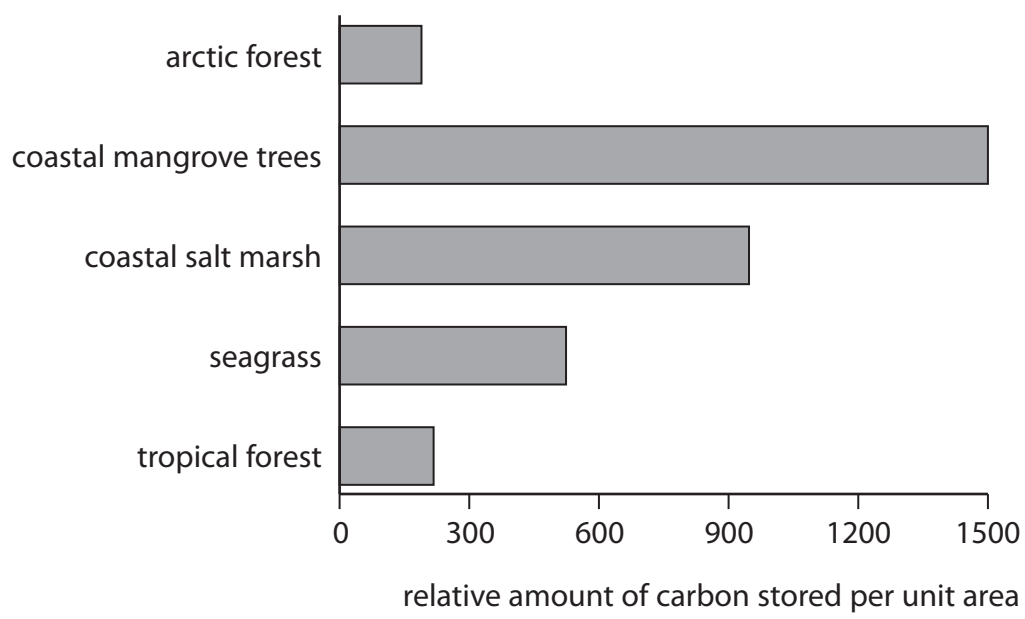

Figure 5

It has been suggested that preserving coastal ecosystems is more effective than reforestation in the mitigation of climate change.

Describe how the data in Figure 5 supports this suggestion.

(2)

.....

.....

.....

.....

(Total for Question 3 = 9 marks)



DO NOT WRITE IN THIS AREA

DO NOT WRITE IN THIS AREA

DO NOT WRITE IN THIS AREA

BLANK PAGE



- 4 (a) Figure 6 shows a poly(ethene) bottle containing substance **K** with one of its hazard symbols showing.

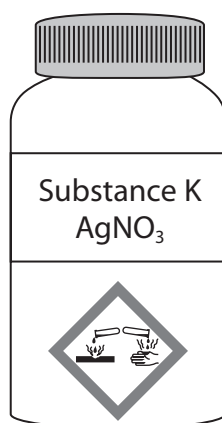

Figure 6

- (i) Explain a safety precaution that should be taken when using a substance with the hazard symbol shown in Figure 6.

(2)

.....

.....

.....

.....

- (ii) Substance **K** has the formula AgNO_3 . Give the name of substance **K**.

(1)

.....

- (iii) State **one** property of poly(ethene) that makes it a suitable material to make a container for storing substances.

(1)

.....

.....



(iv) A student tests a solid for chloride ions.

The student uses the following method.

step 1 dissolve a small amount of the solid in water

step 2 add some dilute hydrochloric acid

step 3 add a few drops of a solution of **K**

step 4 observe whether or not a white precipitate forms.

This method to show whether the solid contains chloride ions will not work.

Explain a change that needs to be made to **step 2** to allow this method to work.

(2)

.....

.....

.....

.....

(b) In the test for carbonate ions, the carbonate ions react with an acid.

Sodium carbonate, Na_2CO_3 , is reacted with dilute hydrochloric acid.

Complete and balance the equation for this reaction.

(3)



(c) The carbonate of element X has the formula X_2CO_3 .
The relative formula mass of this carbonate is 230.

Using this information, calculate the relative atomic mass of X.

(relative atomic masses: C = 12, O = 16)

(2)

.....

.....

.....

relative atomic mass of X =

(Total for Question 4 = 11 marks)

DO NOT WRITE IN THIS AREA

DO NOT WRITE IN THIS AREA

DO NOT WRITE IN THIS AREA



P 7 4 4 2 6 A 0 1 1 3 2

5 (a) (i) Most hydrocarbons found in fossil fuels are members of the alkane homologous series.

State **two** features of an homologous series.

(2)

1

.....

2

.....

(ii) Which molecule is in the same homologous series as CH_4 ?

(1)

A C_5H_{20}

B C_6H_{12}

C C_8H_{18}

D C_9H_{16}

(b) A fossil fuel contains carbon and sulfur.

Explain how the products of the complete combustion of this fossil fuel would affect the environment.

(4)

.....

.....

.....

.....

.....

.....

.....

.....

.....



(c) Incomplete combustion of fuels may produce carbon monoxide.

Write the balanced equation for the incomplete combustion of heptane, C_7H_{16} , where all of the carbon atoms form carbon monoxide.

(2)

(Total for Question 5 = 9 marks)

DO NOT WRITE IN THIS AREA

DO NOT WRITE IN THIS AREA

DO NOT WRITE IN THIS AREA



- 6 (a) Damp iron wool reacts with oxygen in the air.
A student uses the apparatus in Figure 7 to investigate the percentage of oxygen in the atmosphere.

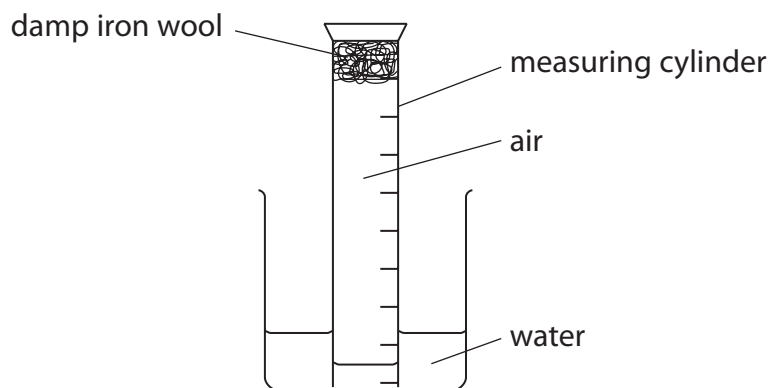

Figure 7

- (i) The initial volume of air in the measuring cylinder was 18.0 cm^3 .

The student left the apparatus overnight.

The volume of gas in the measuring cylinder the next day was 14.5 cm^3 .

To the nearest whole number, what percentage of the air has reacted with the iron wool?

(1)

- A 19%
- B 21%
- C 24%
- D 81%

- (ii) Describe **one** improvement the student could make to this method to ensure that all of the oxygen in the measuring cylinder has reacted.

(2)

.....

.....

.....

.....



DO NOT WRITE IN THIS AREA

DO NOT WRITE IN THIS AREA

DO NOT WRITE IN THIS AREA

- (b) (i) When hydrocarbon fuels are burned, the products are water and carbon dioxide.

Describe what needs to be done to the apparatus in Figure 8 to collect the water and show that carbon dioxide has been produced.

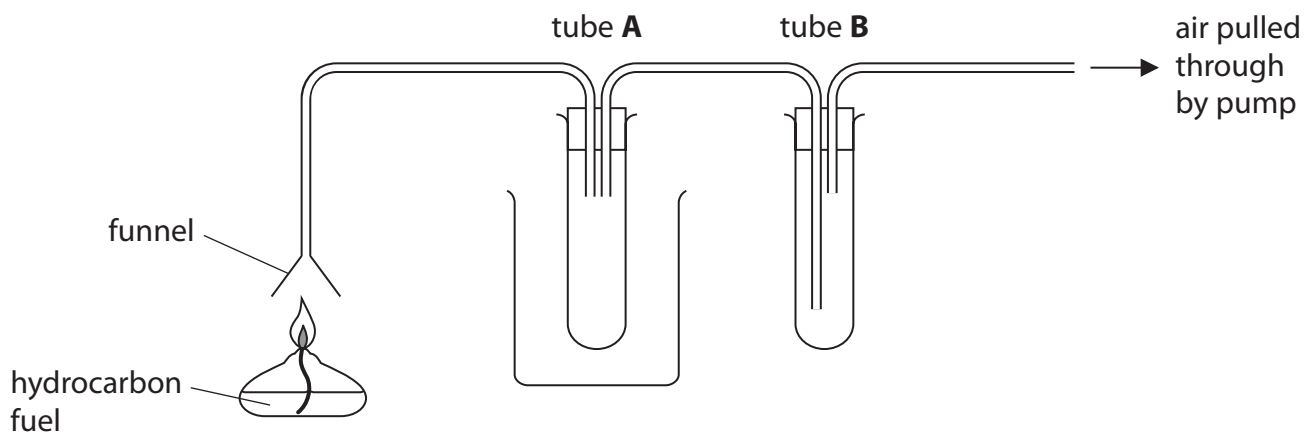

Figure 8

(2)

.....

.....

.....

.....

- (ii) A hydrocarbon, C_xH_y , is burned in excess oxygen, forming 26.4 g of carbon dioxide and 5.4 g of water.

The relative formula mass of C_xH_y is 78.

Calculate the molecular formula of the hydrocarbon C_xH_y .

(relative atomic masses: H = 1.0, C = 12;
relative formula masses: $H_2O = 18$, $CO_2 = 44$)

(4)

.....

.....

.....

.....

.....

molecular formula =

(Total for Question 6 = 9 marks)



- 7 (a) The relative atomic mass of argon is 40 and the relative atomic mass of potassium is 39 but potassium appears after argon in the periodic table.

State why potassium appears after argon in the periodic table.

(1)

- (b) Potassium reacts with water to form two products.

- (i) Give the formulae of both products.

(1)

..... **and**

- (ii) The reaction of potassium with water is exothermic.

On Figure 9, draw and label the reaction profile diagram for this reaction, labelling the activation energy.

(2)



Figure 9



(c) Some reactions are endothermic.

Explain, in terms of bond breaking and bond forming, why some reactions are endothermic.

(3)

.....

.....

.....

.....

.....

.....

DO NOT WRITE IN THIS AREA

DO NOT WRITE IN THIS AREA

DO NOT WRITE IN THIS AREA



(d) Ethene reacts with hydrogen chloride.

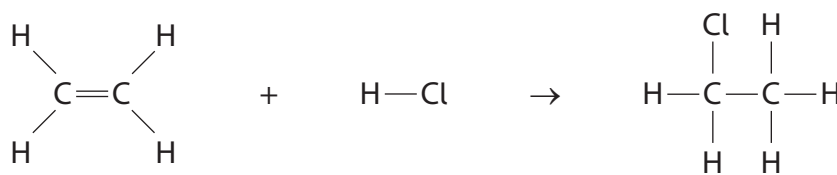

Figure 10 shows the bond energies for the different bonds in the three molecules in the reaction.

| bond | bond energy in kJ mol^{-1} |
|------|-------------------------------------|
| C—H | 412 |
| C=C | 612 |
| C—C | 348 |
| H—Cl | 431 |
| C—Cl | 338 |

Figure 10

Calculate the energy change for this reaction.

(4)

.....

.....

.....

.....

.....

.....

.....

.....

.....

.....

energy change = kJ mol^{-1}

(Total for Question 7 = 11 marks)

DO NOT WRITE IN THIS AREA

DO NOT WRITE IN THIS AREA

DO NOT WRITE IN THIS AREA



- 8 (a) A solid is known to be either aluminium chloride or aluminium sulfate or calcium chloride.

A few drops of sodium hydroxide solution are added to a solution of the solid and the mixture is shaken.

A white precipitate is seen.

A student concludes that the solid is aluminium sulfate.

- (i) Explain why this conclusion may not be correct.

(2)

.....

.....

.....

.....

- (ii) Describe a test the student could use to confirm that the solid contains sulfate ions.

(2)

.....

.....

.....

.....

- (b) A solution containing iron ions is mixed with sodium hydroxide solution.

A green precipitate forms.

After a period of time exposed to air, the precipitate changes colour to brown.

Which statement would explain this change in colour?

(1)

- A** iron(II) ions, Fe^{2+} , are oxidised to iron(III) ions, Fe^{3+}
- B** iron(II) ions, Fe^{2+} , are reduced to iron(III) ions, Fe^{3+}
- C** iron(III) ions, Fe^{3+} , are oxidised to iron(II) ions, Fe^{2+}
- D** iron(III) ions, Fe^{3+} , are reduced to iron(II) ions, Fe^{2+}



*(c) A technician has samples of two substances, **R** and **S**.

R is an ionic solid.

Molecules of **S** contain 2 carbon atoms.

The technician carries out some tests on **R** and on a solution of **S**.

The tests and the results obtained are shown in Figure 11.

| test | result |
|---|---|
| add solid R to water and shake | the white solid dissolves to form a colourless solution |
| add universal indicator to the solution of R | indicator turned blue |
| flame test with solid R | lilac flame produced |
| appearance of solution of S | colourless |
| add universal indicator to solution of S | indicator turns orange |
| add a small piece of magnesium to solution of S | bubbles of gas released and magnesium disappears |
| add spatula measure of solid R to solution of S | bubbles of gas released that turn limewater cloudy solid R disappears |

Figure 11

Identify **R** and **S**, using all of the data in Figure 11, explaining your reasoning from each test.

(6)

.....

.....

.....

.....

.....

.....

.....

.....

.....



DO NOT WRITE IN THIS AREA

DO NOT WRITE IN THIS AREA

DO NOT WRITE IN THIS AREA

(Total for Question 8 = 11 marks)



P 7 4 4 2 6 A 0 2 1 3 2

DO NOT WRITE IN THIS AREA

DO NOT WRITE IN THIS AREA

DO NOT WRITE IN THIS AREA

BLANK PAGE



9 The elements in group 7 of the periodic table are the halogens.

(a) Which row shows the colour and physical state of iodine at room temperature?

(1)

| | colour | physical state |
|-----------------------------------|-----------|----------------|
| <input type="checkbox"/> A | dark grey | solid |
| <input type="checkbox"/> B | red brown | liquid |
| <input type="checkbox"/> C | green | solid |
| <input type="checkbox"/> D | purple | gas |

(b) Iron wool is heated with bromine vapour as shown in Figure 12.

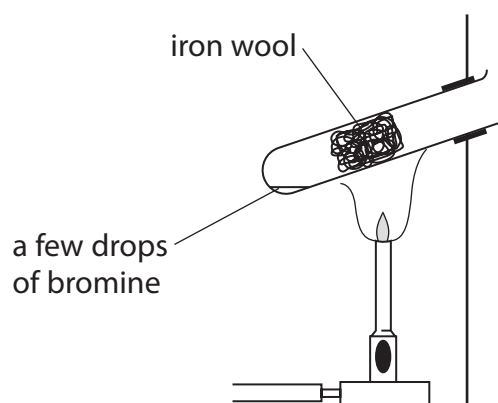

Figure 12

At the end of the reaction, a solid forms at the top of the test tube.

Identify the solid.

(1)

(c) Aluminium reacts with bromine.

Write the balanced equation for the reaction between aluminium and bromine.

(3)

DO NOT WRITE IN THIS AREA

DO NOT WRITE IN THIS AREA

DO NOT WRITE IN THIS AREA

Large writing area with horizontal dotted lines.



P 7 4 4 2 6 A 0 2 5 3 2

(ii) Explain why the displacement reactions of halogens are redox reactions.

(2)

.....

.....

.....

.....

(Total for Question 9 = 13 marks)

DO NOT WRITE IN THIS AREA

DO NOT WRITE IN THIS AREA

DO NOT WRITE IN THIS AREA



10 (a) Figure 13 shows the apparatus used to burn different alcohols.

The mass of each alcohol required to raise the temperature of the water by 40°C is found.

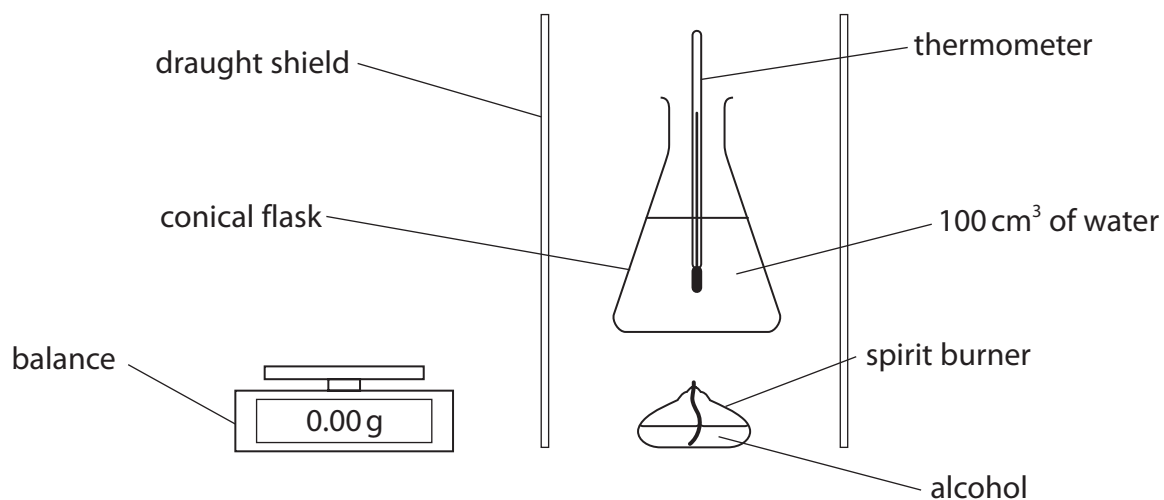

Figure 13

- (i) State **one** variable, apart from the volume of water, that should be kept the same when each alcohol is burned.

(1)

- (ii) It is found that 1.6 g of ethanol is used to raise the temperature of water by 40°C .

Calculate the number of moles of ethanol used.

Give your answer to two significant figures.

(relative formula mass: ethanol = 46)

(2)

number of moles =

- (iii) The mass of ethanol used to raise the temperature of the water by 40°C is higher than the theoretical value.

The experiment is repeated and the same result obtained.

Give a reason why the mass of ethanol used is higher than expected.

(1)

DO NOT WRITE IN THIS AREA

DO NOT WRITE IN THIS AREA

DO NOT WRITE IN THIS AREA

- (b) Poly(phenylethene) is an addition polymer.

Figure 14 shows part of the poly(phenylethene) molecule formed in the addition reaction between three phenylethene monomer molecules.

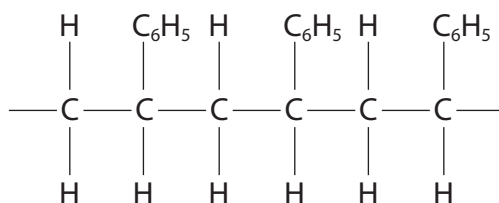

Figure 14

- (i) Draw the structure of **one** phenylethene monomer molecule.

(2)

- (ii) Explain what is **seen** when a few drops of bromine water are shaken with phenylethene.

(3)



DO NOT WRITE IN THIS AREA

(c) Poly(phenylethene) is an addition polymer.

Polyesters are condensation polymers.

Describe the differences between the type of monomer molecules used to form addition polymers and the type of monomer molecules used to form condensation polymers.

(3)

.....

.....

.....

.....

.....

.....

.....

(Total for Question 10 = 12 marks)

TOTAL FOR PAPER = 100 MARKS



DO NOT WRITE IN THIS AREA

DO NOT WRITE IN THIS AREA

DO NOT WRITE IN THIS AREA

BLANK PAGE



DO NOT WRITE IN THIS AREA

DO NOT WRITE IN THIS AREA

DO NOT WRITE IN THIS AREA

BLANK PAGE



P 7 4 4 2 6 A 0 3 1 3 2

DO NOT WRITE IN THIS AREA

DO NOT WRITE IN THIS AREA

DO NOT WRITE IN THIS AREA

BLANK PAGE

