

Surname	Centre Number	Candidate Number
First name(s)		0



**GCSE**

3300U50-1



A23-3300U50-1

**MONDAY, 13 NOVEMBER 2023 – MORNING**

**MATHEMATICS  
UNIT 1: NON-CALCULATOR  
HIGHER TIER**

1 hour 45 minutes

**ADDITIONAL MATERIALS**

The use of a calculator is not permitted in this examination.  
A ruler, a protractor and a pair of compasses may be required.

**INSTRUCTIONS TO CANDIDATES**

Use black ink or black ball-point pen. Do not use gel pen or correction fluid.

You may use a pencil for graphs and diagrams only.

Write your name, centre number and candidate number in the spaces at the top of this page.

Answer **all** questions.

Write your answers in the spaces provided in this booklet. If you run out of space, use the additional page(s) at the back of the booklet, taking care to number the question(s) correctly.

Take  $\pi$  as 3.14.

**INFORMATION FOR CANDIDATES**

You should give details of your method of solution when appropriate.

Unless stated, diagrams are not drawn to scale.

Scale drawing solutions will not be acceptable where you are asked to calculate.

The number of marks is given in brackets at the end of each question or part-question.

In question 1, the assessment will take into account the quality of your linguistic and mathematical organisation, communication and accuracy in writing.

For Examiner's use only		
Question	Maximum Mark	Mark Awarded
1.	4	
2.	4	
3.	4	
4.	6	
5.	3	
6.	2	
7.	4	
8.	4	
9.	3	
10.	3	
11.	4	
12.	4	
13.	5	
14.	3	
15.	2	
16.	7	
17.	3	
18.	4	
19.	2	
20.	3	
21.	6	
<b>Total</b>	<b>80</b>	



NOV233300U50101

### Formula List – Higher Tier

**Area of trapezium** =  $\frac{1}{2}(a + b)h$

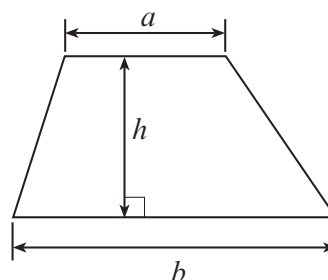

**Volume of prism** = area of cross-section  $\times$  length

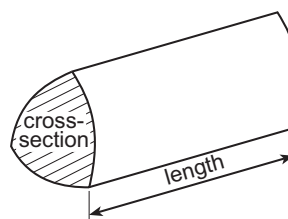

**Volume of sphere** =  $\frac{4}{3}\pi r^3$

**Surface area of sphere** =  $4\pi r^2$

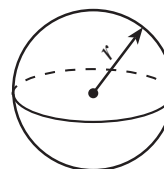

**Volume of cone** =  $\frac{1}{3}\pi r^2 h$

**Curved surface area of cone** =  $\pi r l$

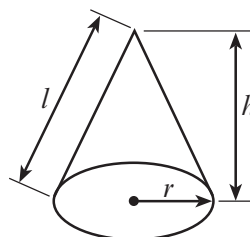

**In any triangle ABC**

**Sine rule**  $\frac{a}{\sin A} = \frac{b}{\sin B} = \frac{c}{\sin C}$

**Cosine rule**  $a^2 = b^2 + c^2 - 2bc \cos A$

**Area of triangle** =  $\frac{1}{2} ab \sin C$

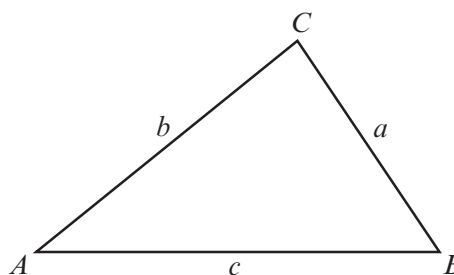

### The Quadratic Equation

The solutions of  $ax^2 + bx + c = 0$  where  $a \neq 0$  are given by  $x = \frac{-b \pm \sqrt{(b^2 - 4ac)}}{2a}$

### Annual Equivalent Rate (AER)

AER, as a decimal, is calculated using the formula  $\left(1 + \frac{i}{n}\right)^n - 1$ , where  $i$  is the nominal interest rate per annum as a decimal and  $n$  is the number of compounding periods per annum.



1. *In this question, you will be assessed on the quality of your organisation, communication and accuracy in writing.*

A cup contains some tea.

Elsie drinks  $\frac{5}{7}$  of the tea.

There are 44 ml of tea left in the cup.

How much tea was in the cup before Elsie drank any?

[2 + 2 OCW]

.....

.....

.....

.....

.....

.....

3300U501  
03



2. The Geometric Mean is a special type of average.

To find the *Geometric Mean* of three numbers, you must:

- multiply the three numbers together, and
- then find the cube root.

(a) Find the Geometric Mean of 100, 0.3 and 0.9. [2]

.....

.....

.....

(b) The Geometric Mean of three numbers is 10.  
Two of the numbers are 8 and 25.  
Find the third number. [2]

.....

.....

.....

.....

.....

.....

.....



3. (a) Write down an expression for the  $n$ th term of the following sequence. [2]

11, 15, 19, 23, ....

.....

.....

.....

.....

(b) The  $n$ th term of a different sequence is given by  $n^2 - 5$ .  
Write down the first three terms of this sequence. [2]

.....

.....

.....

First three terms are ....., ....., .....

3300U501  
05



4. (a) Express 495 as a product of its prime factors in index form. [3]

.....

.....

.....

.....

.....

.....

(b) Explain how your answer to part (a) tells you that 495 is **not** a square number. [1]

.....

.....

.....

.....

(c) Find the Highest Common Factor (HCF) of 495 and 60. [2]

.....

.....

.....

.....

.....

.....

.....

.....



5. In a group of 40 people, some own a cat, some own a dog, and some own both a cat and a dog.

2 people in the group do not own a cat or a dog.

A person is chosen at random from the group.

The probability that the person owns a dog is  $\frac{3}{5}$ .

Complete the Venn diagram.

[3]

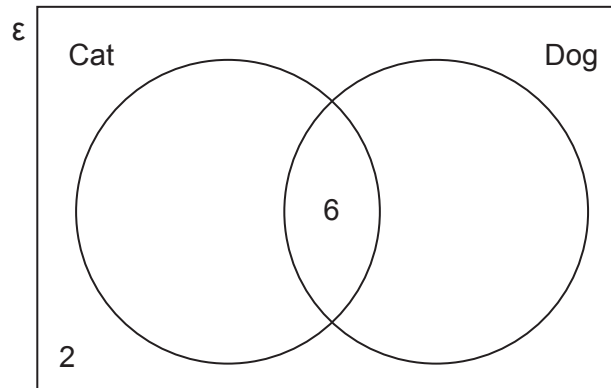

.....

.....

.....

.....

.....

.....

.....

.....



6. A number has been decreased by 10% to give an answer of 34.2.  
What was the original number?

[2]

.....

.....

.....

.....

.....

.....



7.

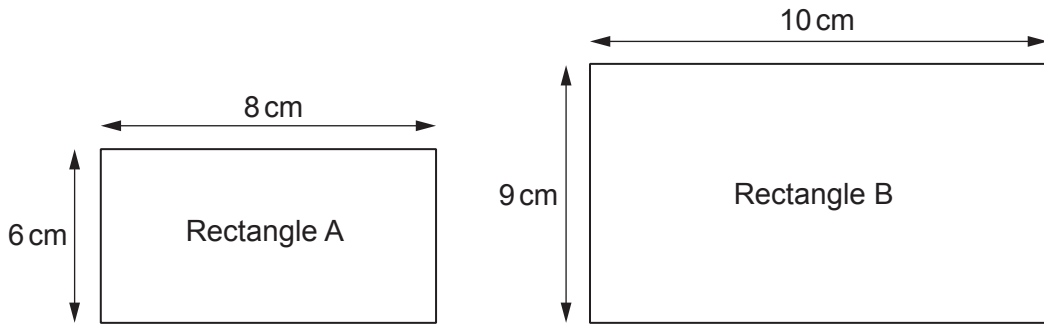

Diagrams not drawn to scale

- (a) Explain why Rectangle A is **not** mathematically similar to Rectangle B. [2]

.....

.....

.....

.....

.....

- (b) Alun changes **only one** of the measurements of **Rectangle B** to make the two rectangles mathematically similar.

Write down a possible length and width of Alun's new rectangle.  
You must show all your working.

[2]

.....

.....

.....

.....

.....

Length = ..... cm

Width = ..... cm





9. Factorise  $x^2 - 8x - 20$ , and hence solve  $x^2 - 8x - 20 = 0$ .

[3]

.....

.....

.....

.....

.....

.....

.....

.....

.....

.....

.....



10. The points  $B$ ,  $C$ ,  $D$  and  $E$  lie on the circumference of a circle, with centre  $O$ .  
 $AF$  is a tangent to the circle.  
 $AO$  is a straight line.

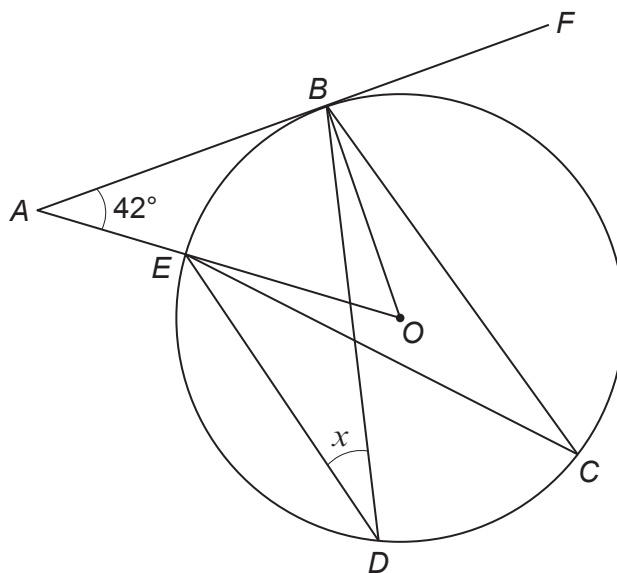

*Diagram not drawn to scale*

Calculate the size of angle  $x$ .  
 You must show all your working.

[3]

.....

.....

.....

.....

.....

.....

.....



11. Solve the equation  $\frac{10x+2}{3} - \frac{7x-3}{5} = 9$ .

[4]

.....

.....

.....

.....

.....

.....

.....

.....

.....

.....

.....

.....

.....

.....

.....

.....

.....

.....

.....

.....

.....

.....

.....



12.

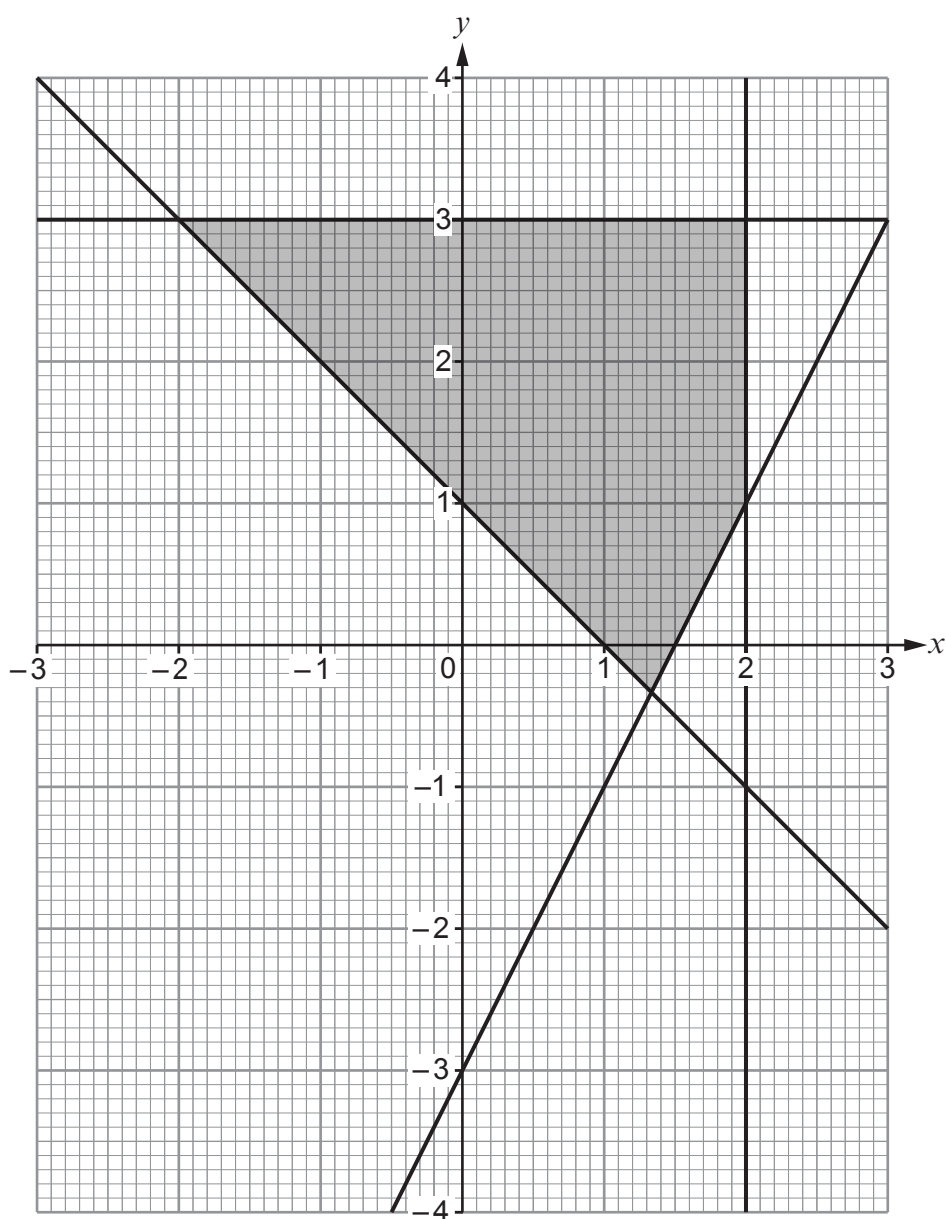

Complete the following table to give the set of inequalities that describes the shaded region shown above.

One inequality has already been written for you.

[4]

.....  
 .....

$y \geq 2x - 3$



13.  $y$  is inversely proportional to the square of  $x$ .  
 $y = 16$  when  $x = 5$ .

(a) Find an expression for  $y$  in terms of  $x$ .

[3]

.....

.....

.....

.....

.....

.....

.....

.....

.....

.....

.....

.....

.....

.....

.....

.....

.....

.....

.....

.....

.....

.....

(b) Use the expression you found in part (a) to complete the following table.

[2]

$x$	5	0.1	
$y$	16		100

.....

.....

.....

.....

.....

.....

.....

.....

.....

.....

.....

.....

.....

.....

.....

.....

.....

.....

.....

.....

.....

.....







16. (a) Circle the correct answer for each of the following statements.

(i)  $64^{\frac{2}{3}}$  is equal to

[1]

$$\frac{128}{3}$$

96

$$\frac{194}{3}$$

16

512

.....

.....

.....

(ii)  $10000^{-\frac{1}{2}}$  is equal to

[1]

$$-\frac{1}{100}$$

$$\frac{1}{100}$$

- 5000

- 100

$$\frac{1}{5000}$$

.....

.....

.....

(b) Express  $0.07\dot{1}4$  as a fraction.

[2]

.....

.....

.....

.....

.....

.....

.....

.....

.....

.....



(c) Simplify  $\sqrt{11\frac{1}{4}}$ .

Give your answer in the form  $\frac{a\sqrt{5}}{b}$ , where  $a$  and  $b$  are integers.

[2]

.....

.....

.....

.....

.....

(d) Give an example of an irrational number that lies between 6 and 7.

[1]

.....

.....

My example of an irrational number is .....





19. The following diagram shows a sketch of  $y = \tan x$  for values of  $x$  from  $0^\circ$  to  $360^\circ$ .

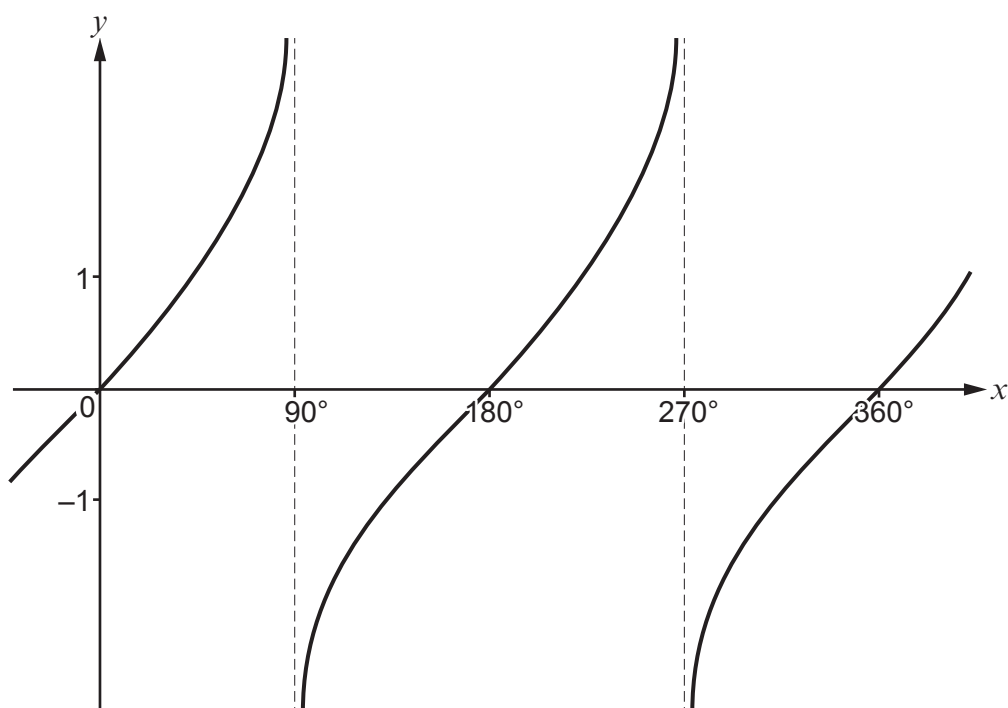

Given that  $\tan 71^\circ = 2.9042$ , correct to 4 decimal places, write down all the solutions of the equation

$$\tan x = -2.9042$$

for values of  $x$  from  $0^\circ$  to  $360^\circ$ .

[2]

.....

.....

.....

.....

.....

.....

.....

.....



20. The diagram shows a sketch of  $y = f(x)$ .  
The point where the curve has a gradient of 0 is labelled  $A$  and has coordinates  $(8, -1)$ .

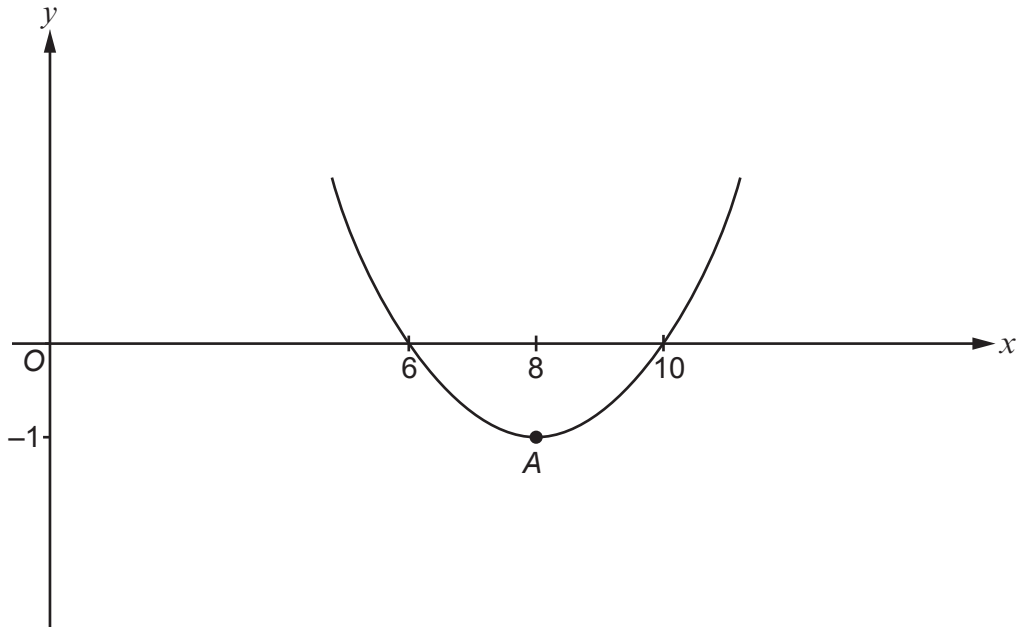

On the axes below, sketch the curve  $y = f(x+3)$ .

You must:

- indicate the coordinates of any point where the new curve crosses an axis
- complete the coordinates of the point on the curve where the gradient is 0.

[3]



The coordinates of the point on the curve where the gradient is 0 are ( ..... , ..... ).



21. (a) A box contains seven black counters, three white counters and one red counter. Aled takes two counters at random from the box. These counters are not replaced.

Calculate the probability that the two counters that Aled chose are both the same colour. [3]

.....

.....

.....

.....

.....

.....

.....

.....

.....

.....

- (b) A second box contains  $n$  yellow cards and  $(n+1)$  red cards. Delyth takes two cards at random from the second box. These cards are not replaced.

What is the probability that the two cards that Delyth chose are both yellow? Give your answer as an algebraic fraction in its simplest form. [3]

.....

.....

.....

.....

.....

.....

.....

.....

.....

.....

**END OF PAPER**



