

Please check the examination details below before entering your candidate information

Candidate surname

Other names

Centre Number

Candidate Number

--	--	--	--	--

--	--	--	--	--

## Pearson Edexcel International GCSE

**Monday 3 June 2024**

Morning (Time: 2 hours)

Paper  
reference

**4MA1/2H**

### Mathematics A

**PAPER 2H**

**Higher Tier**



**You must have:** Ruler graduated in centimetres and millimetres, protractor, pair of compasses, pen, HB pencil, eraser, calculator. Tracing paper may be used.

Total Marks

### Instructions

- Use **black** ink or ball-point pen.
- **Fill in the boxes** at the top of this page with your name, centre number and candidate number.
- Answer **all** questions.
- Without sufficient working, correct answers may be awarded no marks.
- Answer the questions in the spaces provided  
– *there may be more space than you need.*
- **Calculators may be used.**
- You must **NOT** write anything on the formulae page.
- Anything you write on the formulae page will gain **NO** credit.

### Information

- The total mark for this paper is 100.
- The marks for **each** question are shown in brackets  
– *use this as a guide as to how much time to spend on each question.*

### Advice

- Read each question carefully before you start to answer it.
- Check your answers if you have time at the end.

Turn over ►

P73994A

©2024 Pearson Education Ltd.  
F:1/1/1/1/1/



  
Pearson

International GCSE Mathematics

Formulae sheet – Higher Tier

**Arithmetic series**

Sum to  $n$  terms,  $S_n = \frac{n}{2} [2a + (n - 1)d]$

**Area of trapezium** =  $\frac{1}{2}(a + b)h$

**The quadratic equation**

The solutions of  $ax^2 + bx + c = 0$  where  $a \neq 0$  are given by:

$$x = \frac{-b \pm \sqrt{b^2 - 4ac}}{2a}$$

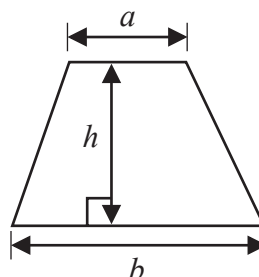

**Trigonometry**

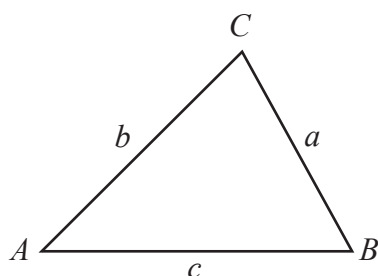

**In any triangle ABC**

**Sine Rule**  $\frac{a}{\sin A} = \frac{b}{\sin B} = \frac{c}{\sin C}$

**Cosine Rule**  $a^2 = b^2 + c^2 - 2bc \cos A$

**Area of triangle** =  $\frac{1}{2} ab \sin C$

**Volume of cone** =  $\frac{1}{3} \pi r^2 h$

**Curved surface area of cone** =  $\pi r l$

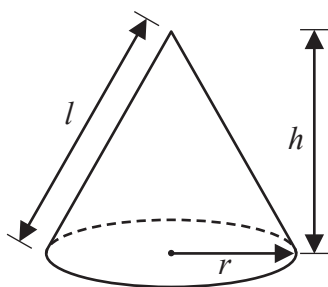

**Volume of prism**

= area of cross section  $\times$  length

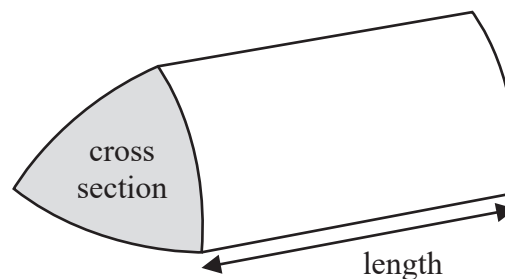

**Volume of cylinder** =  $\pi r^2 h$

**Curved surface area of cylinder** =  $2\pi r h$

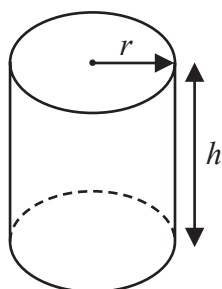

**Volume of sphere** =  $\frac{4}{3} \pi r^3$

**Surface area of sphere** =  $4\pi r^2$

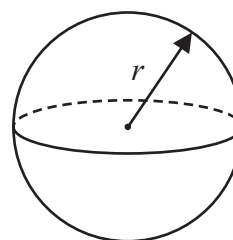

DO NOT WRITE IN THIS AREA

DO NOT WRITE IN THIS AREA

DO NOT WRITE IN THIS AREA



DO NOT WRITE IN THIS AREA

Answer ALL TWENTY FIVE questions.

Write your answers in the spaces provided.

You must write down all the stages in your working.

1 Here are eight numbers written in order of size

$h$     6    7    8     $j$     16     $k$      $k$

where  $h$ ,  $j$  and  $k$  are integers.

The median of the eight numbers is 10

The mode of the eight numbers is 18

The range of the eight numbers is 13

Work out the value of  $h$ , the value of  $j$  and the value of  $k$

$h = \dots\dots\dots$

$j = \dots\dots\dots$

$k = \dots\dots\dots$

(Total for Question 1 is 3 marks)



P 7 3 9 9 4 A 0 3 2 8

2 (a) On the grid, draw the straight line with equation

(i)  $y = 2$

(ii)  $x = 6$

(iii)  $y = x + 1$

Label each line with its equation.

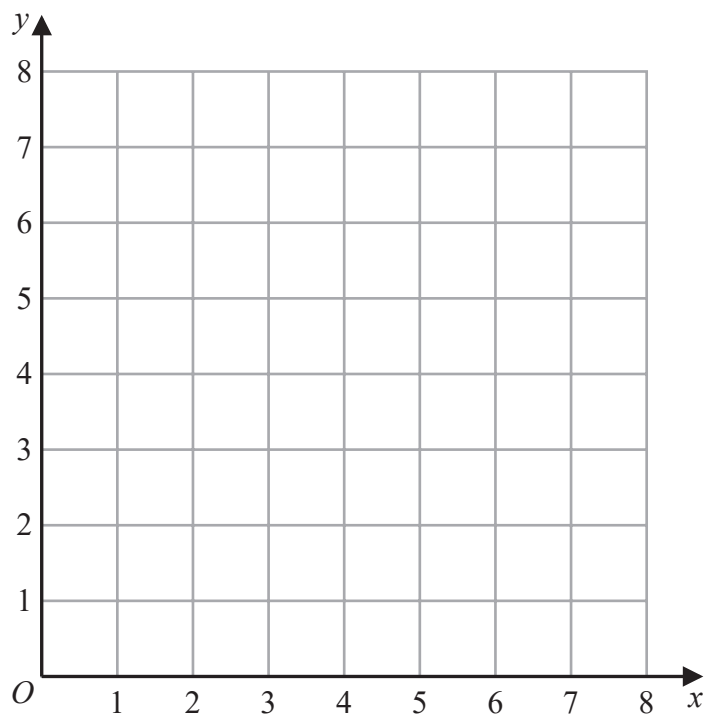

(3)

(b) Show, by shading on the grid, the region that satisfies all three of the inequalities

$$y \geq 2$$

$$x \leq 6$$

$$y \leq x + 1$$

Label the region **R**

(1)

(Total for Question 2 is 4 marks)



DO NOT WRITE IN THIS AREA

DO NOT WRITE IN THIS AREA

DO NOT WRITE IN THIS AREA

3 A plane takes 9 hours 36 minutes to fly from New Delhi to Perth.

The plane flies at an average speed of 820 km/h.

Work out the total distance the plane flies.

..... km

**(Total for Question 3 is 3 marks)**

4 Show that  $2\frac{4}{7} \times 3\frac{1}{9} = 8$

**(Total for Question 4 is 3 marks)**



5 The diagram shows triangle  $ABC$

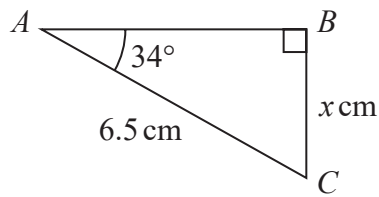

Diagram **NOT** accurately drawn

Work out the value of  $x$   
Give your answer correct to one decimal place.

$x =$  .....

(Total for Question 5 is 3 marks)

6 Change a speed of  $w$  metres per second to a speed in kilometres per hour.  
Give your answer in terms of  $w$  in its simplest form.

..... kilometres per hour

(Total for Question 6 is 3 marks)



DO NOT WRITE IN THIS AREA

DO NOT WRITE IN THIS AREA

DO NOT WRITE IN THIS AREA

7 The diagram shows a 6-sided shape  $ABCDEF$

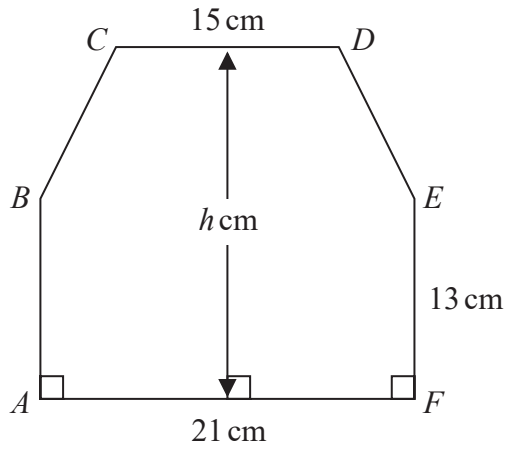

Diagram **NOT** accurately drawn

$$AF = 21 \text{ cm} \quad CD = 15 \text{ cm} \quad AB = FE = 13 \text{ cm}$$

The perpendicular height of the shape is  $h$  cm  
 $CD$  is parallel to  $AF$

The area of the shape is  $390 \text{ cm}^2$

Work out the value of  $h$

$$h = \dots\dots\dots$$

(Total for Question 7 is 4 marks)



8 Ishir plants 600 bulbs in a garden.

He plants tulip bulbs, crocus bulbs and daffodil bulbs so that

number of tulip bulbs : number of crocus bulbs : number of daffodil bulbs = 9 : 4 : 2

45% of the tulip bulbs are for yellow flowers.

$\frac{5}{8}$  of the crocus bulbs are for yellow flowers.

All of the daffodil bulbs are for yellow flowers.

Work out the number of bulbs that are for yellow flowers.

.....  
(Total for Question 8 is 5 marks)

DO NOT WRITE IN THIS AREA

DO NOT WRITE IN THIS AREA

DO NOT WRITE IN THIS AREA



DO NOT WRITE IN THIS AREA

DO NOT WRITE IN THIS AREA

DO NOT WRITE IN THIS AREA

9 Giovanni invests 4500 koruna in a savings account for 4 years.  
He gets 2.4% per year compound interest.

Work out how much money Giovanni will have in the savings account at the end of 4 years.

Give your answer correct to the nearest koruna.

..... koruna

**(Total for Question 9 is 3 marks)**



DO NOT WRITE IN THIS AREA

DO NOT WRITE IN THIS AREA

DO NOT WRITE IN THIS AREA

10 Solve the simultaneous equations

$$\begin{aligned}6x + 4y &= 1 \\3x + 5y &= 8\end{aligned}$$

Show clear algebraic working.

$x = \dots\dots\dots$

$y = \dots\dots\dots$

(Total for Question 10 is 3 marks)

11 (i) Factorise  $x^2 + 9x - 22$

$\dots\dots\dots$   
(2)

(ii) Hence, solve  $x^2 + 9x - 22 = 0$

$\dots\dots\dots$   
(1)

(Total for Question 11 is 3 marks)



DO NOT WRITE IN THIS AREA

DO NOT WRITE IN THIS AREA

DO NOT WRITE IN THIS AREA

12 Ali uses a fitness tracker to count the number of steps he walks each day for 7 days.

For the first 4 days, his mean number of steps is 11 800  
For the next 3 days, his mean number of steps is 13 207

Work out his mean number of steps for the 7 days.

.....  
(Total for Question 12 is 3 marks)



13 The table gives information about the distances, in km, that 70 teachers travel to school.

Distance ( $d$ km)	Frequency
$0 < d \leq 10$	7
$10 < d \leq 20$	17
$20 < d \leq 30$	18
$30 < d \leq 40$	14
$40 < d \leq 50$	10
$50 < d \leq 60$	4

(a) Complete the cumulative frequency table.

Distance ( $d$ km)	Cumulative frequency
$0 < d \leq 10$	
$0 < d \leq 20$	
$0 < d \leq 30$	
$0 < d \leq 40$	
$0 < d \leq 50$	
$0 < d \leq 60$	

(1)

(b) On the grid opposite, draw a cumulative frequency graph for your table.

(2)



DO NOT WRITE IN THIS AREA

DO NOT WRITE IN THIS AREA

DO NOT WRITE IN THIS AREA

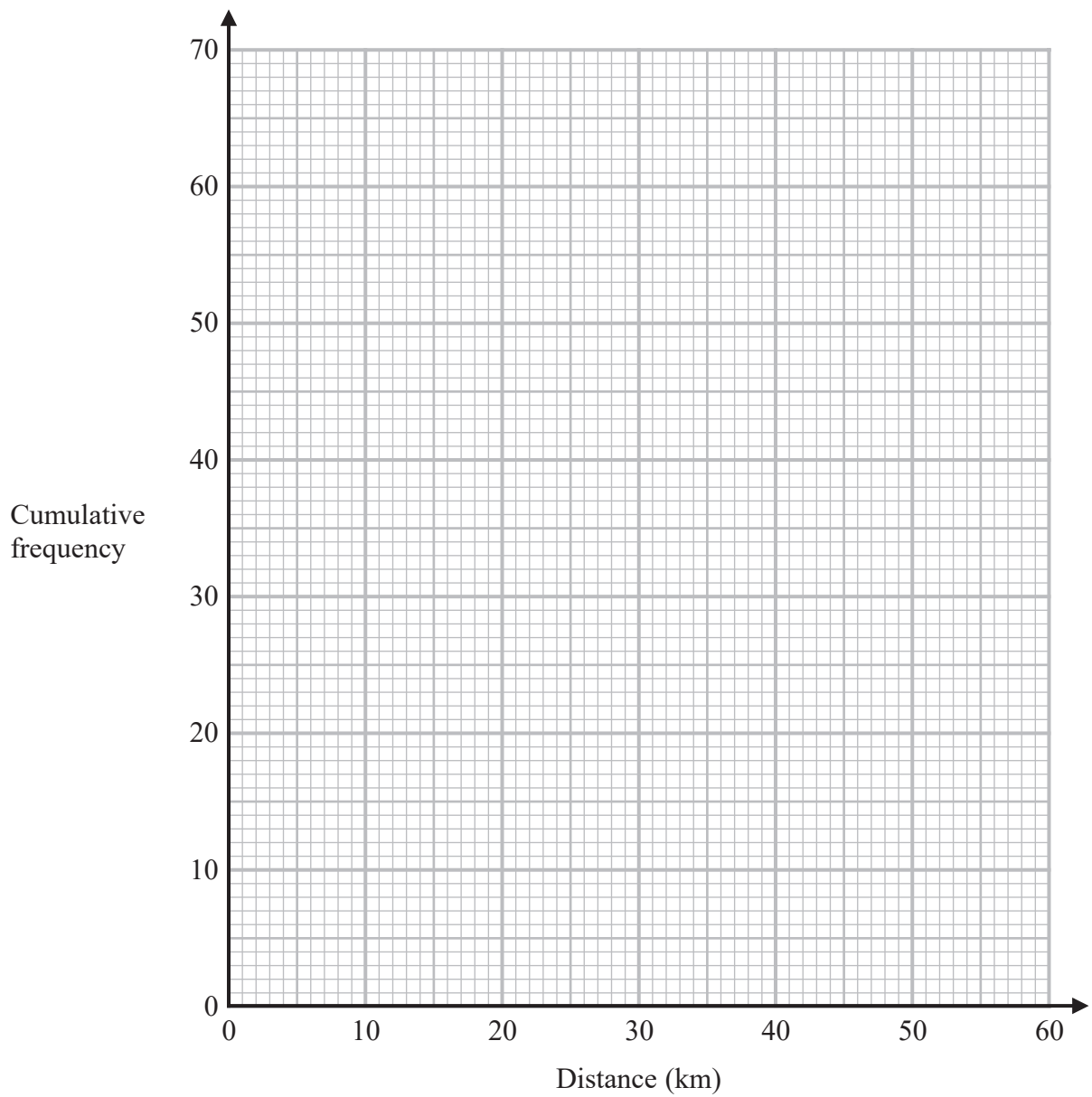

(c) Use your graph to find an estimate for the interquartile range of the distances.

..... km  
(2)

(d) Use your graph to find an estimate for the number of teachers who travel more than 46 km.

.....  
(2)

**(Total for Question 13 is 7 marks)**



DO NOT WRITE IN THIS AREA

DO NOT WRITE IN THIS AREA

DO NOT WRITE IN THIS AREA

14 (a) Show that  $3y(2y + 5)(y + 7)$  can be written in the form  $ay^3 + by^2 + cy$  where  $a, b$  and  $c$  are integers.

(3)

(b) Solve  $\frac{2x + 3}{5} + \frac{6x - 5}{4} = \frac{163}{100}$

Show clear algebraic working.

$x = \dots\dots\dots$   
(4)

(Total for Question 14 is 7 marks)



DO NOT WRITE IN THIS AREA

DO NOT WRITE IN THIS AREA

DO NOT WRITE IN THIS AREA

15 (a) Make  $g$  the subject of  $e = \sqrt{\frac{7g + 5}{11 + 2g}}$

.....  
(4)

(b) Solve the inequality  $3y^2 + 4y - 32 > 0$   
Show your working clearly.

.....  
(3)

(Total for Question 15 is 7 marks)



- 16 60 art students were asked if they would like to attend workshops for knitting ( $K$ ), for photography ( $P$ ) or for embroidery ( $E$ )

Of these students

- 9 chose knitting, photography and embroidery
- 17 chose knitting and photography
- 16 chose photography and embroidery
- 20 chose knitting and embroidery
- 28 chose photography
- 39 chose embroidery
- 2 chose none of the workshops

- (a) Using this information, complete the Venn diagram to show the numbers of students in each subset.

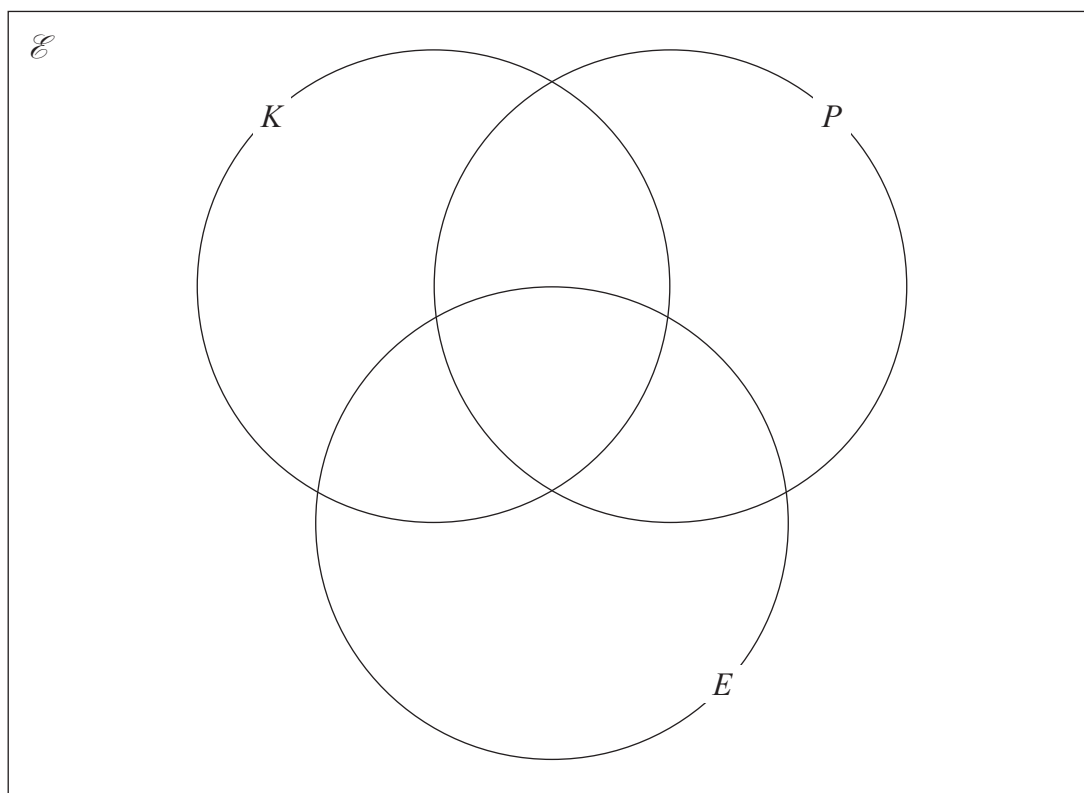

(3)



DO NOT WRITE IN THIS AREA

DO NOT WRITE IN THIS AREA

DO NOT WRITE IN THIS AREA

One of the students is chosen at random.

Given that this student chose photography,

(b) find the probability that this student also chose knitting.

.....  
(2)

(c) Find  $n(P \cap K')$

.....  
(1)

(d) Find  $n([P \cup E] \cap K)$

.....  
(1)

**(Total for Question 16 is 7 marks)**

**17**  $Q$  is directly proportional to the square root of  $d$

$Q = 4.5$  when  $d = 324$

Find a formula for  $Q$  in terms of  $d$

.....  
**(Total for Question 17 is 3 marks)**



18 The straight line **P** has equation  $5y + 2x = 7$

Find the gradient of a straight line that is perpendicular to **P**

.....  
(Total for Question 18 is 2 marks)

19  $G = \frac{c}{2f - 3h}$

$c = 8$  correct to the nearest whole number

$f = 6.62$  correct to 2 decimal places

$h = 1.2$  correct to 1 decimal place

Work out the lower bound for the value of  $G$   
Give your answer correct to 3 decimal places.  
Show your working clearly.

.....  
(Total for Question 19 is 3 marks)



DO NOT WRITE IN THIS AREA

DO NOT WRITE IN THIS AREA

DO NOT WRITE IN THIS AREA

20 Given that  $k = x - y$  and  $x = \frac{1}{4y}$

express  $\frac{5k}{x + 2}$  in the form  $\frac{a - by^2}{c + dy}$  where  $a, b, c$  and  $d$  are integers.

.....  
(Total for Question 20 is 3 marks)



21 The diagram shows a square  $ABCD$  and a circle.

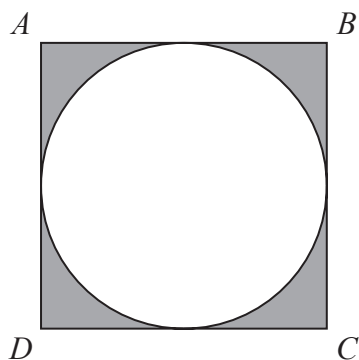

Diagram **NOT**  
accurately drawn

DO NOT WRITE IN THIS AREA

DO NOT WRITE IN THIS AREA

DO NOT WRITE IN THIS AREA

The sides of the square are tangents to the circle.

The total area of the shaded regions is  $80 \text{ cm}^2$

Work out the length of  $AC$

Give your answer correct to 3 significant figures.



DO NOT WRITE IN THIS AREA

DO NOT WRITE IN THIS AREA

DO NOT WRITE IN THIS AREA

..... cm

**(Total for Question 21 is 5 marks)**

**Turn over for Question 22**



DO NOT WRITE IN THIS AREA

DO NOT WRITE IN THIS AREA

DO NOT WRITE IN THIS AREA

22 The straight line **L** has equation  $x + y = 5$

The curve **C** has equation  $2x^2 + 3y^2 = 210$

Find the coordinates of the points where **L** and **C** intersect.  
Show clear algebraic working.

(....., .....) (....., .....)

(Total for Question 22 is 5 marks)



DO NOT WRITE IN THIS AREA

DO NOT WRITE IN THIS AREA

DO NOT WRITE IN THIS AREA

23 Simplify  $\frac{30 \times 25^{2x+7}}{\sqrt{180} \times (\sqrt{5})^{4x+9}}$

Give your answer in the form  $5^w$  where  $w$  is an expression in terms of  $x$   
Show each stage of your working clearly.

.....  
(Total for Question 23 is 3 marks)

Turn over for Question 24



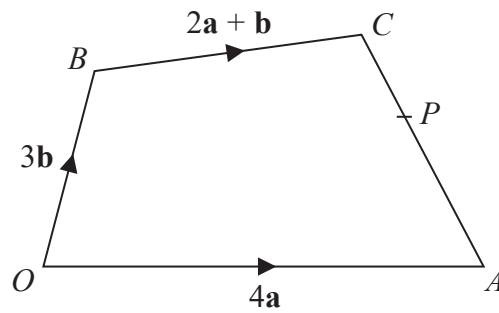

Diagram **NOT**  
accurately drawn

The diagram shows a quadrilateral  $OACB$  in which

$$\vec{OA} = 4\mathbf{a} \quad \vec{OB} = 3\mathbf{b} \quad \vec{BC} = 2\mathbf{a} + \mathbf{b}$$

- (a) Find  $\vec{AC}$  in terms of  $\mathbf{a}$  and  $\mathbf{b}$   
Give your answer in its simplest form.

$$\vec{AC} = \dots\dots\dots (2)$$

DO NOT WRITE IN THIS AREA

DO NOT WRITE IN THIS AREA

DO NOT WRITE IN THIS AREA



DO NOT WRITE IN THIS AREA

DO NOT WRITE IN THIS AREA

DO NOT WRITE IN THIS AREA

The point  $P$  lies on  $AC$  such that  $AP:PC = 3:2$

The point  $Q$  is such that  $OPQ$  and  $BCQ$  are straight lines.

- (b) Using a vector method, find  $\vec{OQ}$  in terms of  $\mathbf{a}$  and  $\mathbf{b}$   
Give your answer in its simplest form.  
Show your working clearly.

$$\vec{OQ} = \dots\dots\dots (4)$$

(Total for Question 24 is 6 marks)

Turn over for Question 25



P 7 3 9 9 4 A 0 2 5 2 8

25 The diagram shows a sketch of the graph of  $y = 2\sin(x + 60)^\circ$

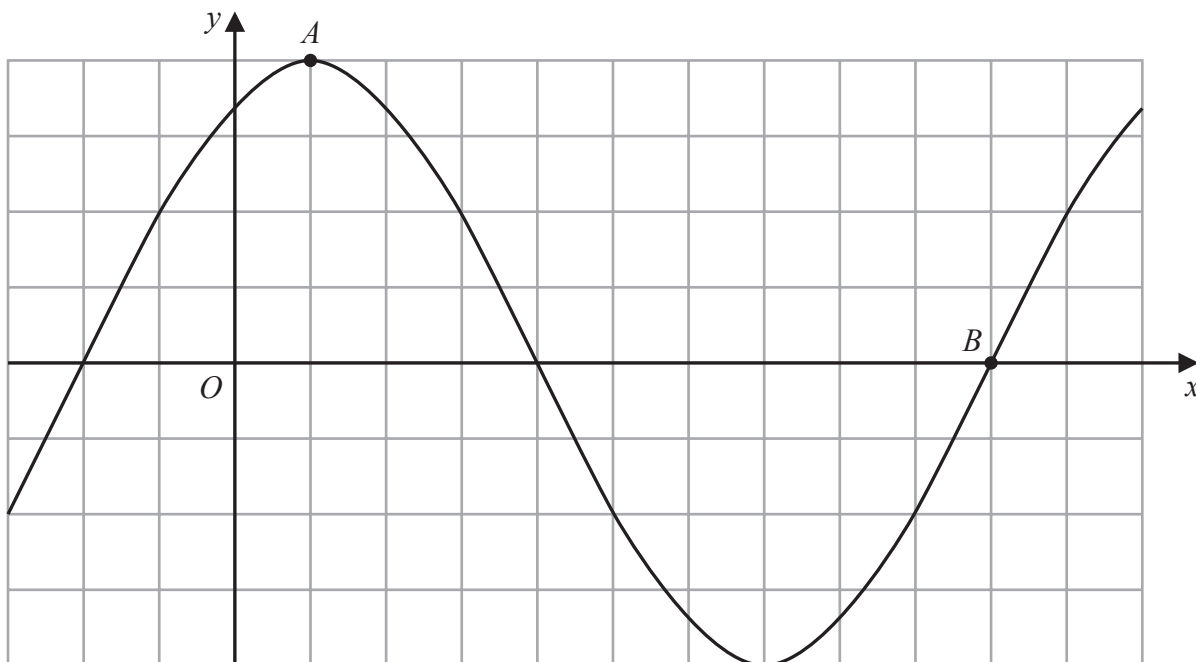

(i) Find the coordinates of the point  $A$

(....., .....)  
(1)

(ii) Find the coordinates of the point  $B$

(....., .....)  
(1)

(Total for Question 25 is 2 marks)

**TOTAL FOR PAPER IS 100 MARKS**



DO NOT WRITE IN THIS AREA

DO NOT WRITE IN THIS AREA

DO NOT WRITE IN THIS AREA

**BLANK PAGE**



P 7 3 9 9 4 A 0 2 7 2 8

DO NOT WRITE IN THIS AREA

DO NOT WRITE IN THIS AREA

DO NOT WRITE IN THIS AREA

**BLANK PAGE**

