

1. Jenna is going on holiday to North America. She checks the exchange rate and sees that one dollar (\$) is worth £0.73 (or 73 pence). She wants to take \$225 with her. How much will this cost in pounds and pence?

It will cost her £_____ to buy \$225 (1 mark)

2. Sumaiya and Georgina live 20 kilometres apart on a straight road. One day they decide to meet somewhere along this road. Sumaiya cycles at 24 kilometres per hour and Georgina walks at 6 kilometres per hour. They both leave their houses at a quarter past eight in the morning. At what time do they meet?

The time Sumaiya and Georgina will meet is _____ a.m. (1 mark)

3. Consecutive numbers are numbers which follow each other in order, without gaps, from smallest to largest.

a) Find three consecutive whole numbers which, when added together, make 3126.

_____ and _____ and _____ (1 mark)

b) Five consecutive odd numbers, when added together, make 3225. Which of these five numbers is the largest?

_____ (1 mark)

4. Work out the perimeter of the following shape

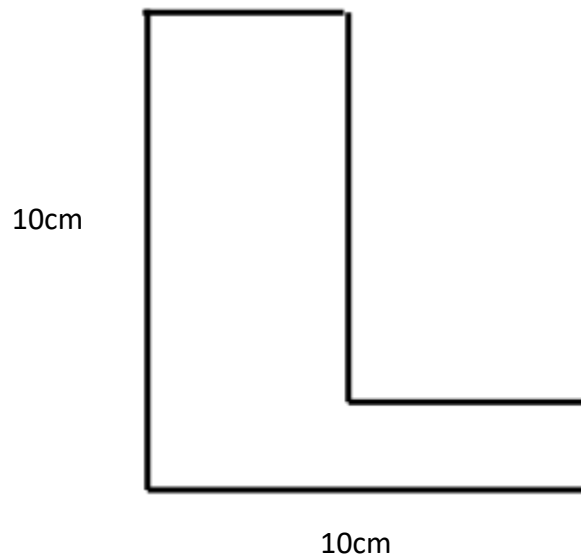

_____ cm

(1 mark)

5. The mass of a crusty loaf is 740 grams. What is the total mass in kg of 24 crusty loaves?

_____ kg

(1 mark)

6. Which of these fractions is not equivalent to the others?

$$\frac{9}{24}$$

$$\frac{27}{72}$$

$$\frac{1.5}{4}$$

$$\frac{18}{56}$$

$$\frac{3}{8}$$

The fraction which is not equivalent to the others is _____

(1 mark)

7. A cuboid has the following measurements:

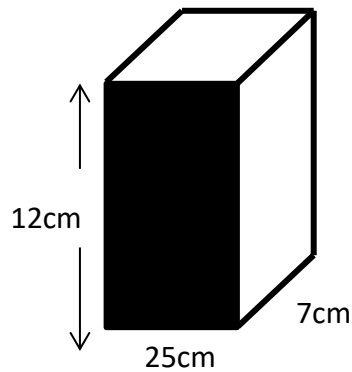

Please note, the diagram is not drawn to size

What is the ratio of the area of the shaded face of the cuboid to the volume of the cuboid?

Give your answer in its simplest form.

The ratio of the area of the shaded face to the volume of the cuboid is

_____ to _____

(1 mark)

8. Three regular hexagons of side 1cm are placed together as shown below. The perimeter of the shape is 14cm. What is the perimeter of the shape, if six regular hexagons are placed the same way?

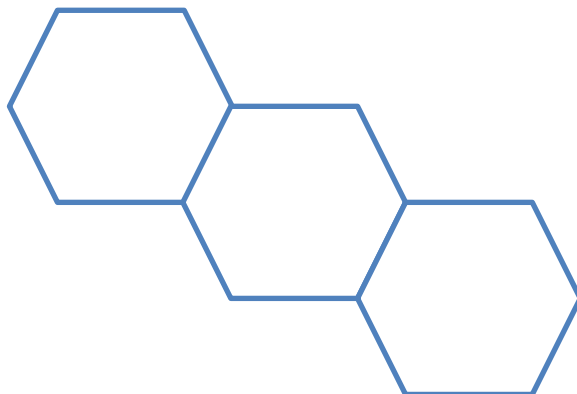

Please note, the diagram is not drawn to size

The perimeter of the shape is _____ cm

(1 mark)