

CSSE

The Consortium of Selective Schools in Essex

MATHEMATICS PAPER FOR 2016 ENTRY – TEST 2

Name: _____

Candidate Number: _____

Primary School: _____

Boy or Girl: _____

Date of Birth: _____

Today's Date: _____

Test Taken At: _____

READ THE FOLLOWING CAREFULLY:

1. Do not open this booklet until you are told to do so.
2. You may work the questions out in your head, or by writing on the white area around the question.
3. Work as quickly and as carefully as you can.
4. Make any alterations to your answers clearly. You will not lose marks for crossing out.
5. You will have **60 minutes** to do the test. If you find you cannot do a question, **do not waste time on it but go on to the next one.**
6. Once the test has begun, you should not ask about questions in the test.
7. The use of electronic calculators of any description (including calculator watches) is **NOT** permitted.

All rights reserved, including translation. No part of this publication may be reproduced or transmitted in any form or by any means, electronic or mechanical, including photocopying, recording or duplication in any information storage and retrieval system, without permission in writing from CSSE, and may not be photocopied or otherwise reproduced with the terms of any licence granted by the Copyright Licensing Agency Ltd.

Copyright © The Consortium of Selective Schools in Essex, 2015.

NOT TO BE FILLED IN BY PUPIL		
PAGE	SCORE	
	R	W
1 (12)		
2 (9)		
3 (7)		
4 (7)		
5 (4)		
6 (4)		
7 (3)		
8 (5)		
9 (3)		
10 (3)		
11 (3)		
TOTAL (60)		
INITIALS OF MARKERS:		

You have sixty minutes to complete this paper.
Do your working out in the spaces on the paper.

Question (and working space)

Please do
not write in
this space

1 For each part of this question, complete the sequence by inserting the correct number in each of the empty spaces.

(a) The rule for this sequence is "divide by 10".

....., 7020, 702,, 7.02,

(b) The rule for this sequence is "multiply by 20".

....., 0.64, 12.8,

(c) The rule for this sequence is "subtract $\frac{1}{4}$ ".

....., $\frac{3}{4}$, $\frac{1}{2}$, $\frac{1}{4}$,,

(d) The rule for this sequence is "add $\frac{1}{6}$ ".

$\frac{2}{3}$,,, $1\frac{1}{6}$

(e) The rule for this sequence is "divide by 3".

18, 6, 2,,

R
W
(12)

Question (and working space)

Please do not write in this space

2 For each part of this question, complete the calculation by inserting the correct digit in each of the empty squares.

(a)

$$\begin{array}{r}
 139 + \\
 5 \square 7 \\
 \hline
 65 \square
 \end{array}$$

(b)

$$\begin{array}{r}
 335 - \\
 1 \square 8 \\
 \hline
 \square 7 \square
 \end{array}$$

(c)

$$\begin{array}{r}
 1 \square 8 \times \\
 7 \\
 \hline
 \square 6 6
 \end{array}$$

(d)

$$66 \square \div 35 = \square 9$$

R
W

(9)

Question (and working space)

Please do not write in this space

- 3 This question involves completing 'magic' squares. A magic square is a grid of nine numbers arranged so that every row, every column and both diagonals have the same fixed total.

For example:

6	1	8
7	5	3
2	9	4

In this magic square, each row, each column and each of the diagonals add to 15.

- (a) Insert the correct number in the two empty positions to complete this magic square.

5	4	9
10		2
	8	7

- (b) Insert the correct number in the two **unshaded** positions to part complete this magic square.

5		7
	8	
		11

- 4 (a) What is the value of 11^2 ?

- (b) Calculate 13×13 .

- (c) How many square numbers are there between 101 and 200?

ANSWER

R
W
(7)

Question (and working space)

ANSWER

Please do not write in this space

5 (a) What is the angle between the hour hand and the minute hand of a clock, at 3 o'clock?

(b) Through how many degrees does the hour hand of a clock turn between noon and 5 o'clock in the afternoon?

(c) Through how many degrees does the minute hand of a clock turn between 0900 and 0945?

6 (a) Calculate a quarter of £62.

(b) Calculate 10% of £62.

(c) Calculate 11% of £62.

(d) A coat costing £62 is reduced in a sale by £12.40. What percentage discount is this?

R
W

(7)

Question (and working space)

ANSWER

Please do not write in this space

7 Jon is using square ceramic tiles, each 20cm x 20cm, to cover a rectangular worktop in his greenhouse.



He can fit exactly 6 tiles along the shorter edge of the worktop and 15 along the length.

(a) How many tiles will he use, altogether, to cover the worktop?

(b) What is the length of the worktop? Give your answer in metres (m).

.....m

(c) What is the perimeter of the worktop? Give your answer in metres (m).

.....m

(d) What is the area of the worktop? Give your answer in square metres (m²).

.....m²

R
W
(4)

Question (and working space)

ANSWER

Please do not write in this space

- 8 Ola is planning to complete a sponsored run for Red Nose Day. He collected a number of different promises, from his family, on his sponsor form.

Mum	50p per completed mile
Dad	£5 plus 25p per completed mile
Nan	£10
Grandad	10p for the first mile, 20p for the second mile, 30p for third mile, <i>and so on ...</i>
Uncle Jay	£15

He hopes to complete *either* 8 or 10 miles.

- (a) If Ola completes 8 miles, how much money will he collect from Dad?

- (b) If Ola completes 8 miles, how much money will he collect from Grandad?

- (c) If Ola completes 8 miles, how much money will he collect from everyone?

- (d) How much extra will Ola collect, in total, if he completes the extra 2 miles and runs 10 miles (rather than 8 miles)?

R
W

(4)

Question (and working space)

ANSWER

Please do not write in this space

9 Sasha is selling greetings cards and gifts for Mothers' Day.

Medium card & envelope	£1.79
Large card & envelope	£2.59
Small chocolate selection	£1.49
Dried flower (bunch)	£3.65
Candles in holder	£5.49

(a) What is the total cost of a large card & envelope, candles and a small chocolate selection?

(b) How much change would be needed, from a £10 note, if Sasha sells a medium card & envelope with a bunch of dried flowers?

(c) Sasha is asked for an itemised receipt for a bill of £7.73. He knew that three items, bought together, have that total price.

Which three prices total £7.73?

£.....

and

£.....

and

£.....

R
W
(3)

GO TO NEXT PAGE

10 The diagram shows three different routes from Peter's factory (marked as F) to his warehouse (marked as W). Each section of the route is either motorway (labelled M), main road (labelled A) or minor road (labelled B). The length of each section of the route is also stated.

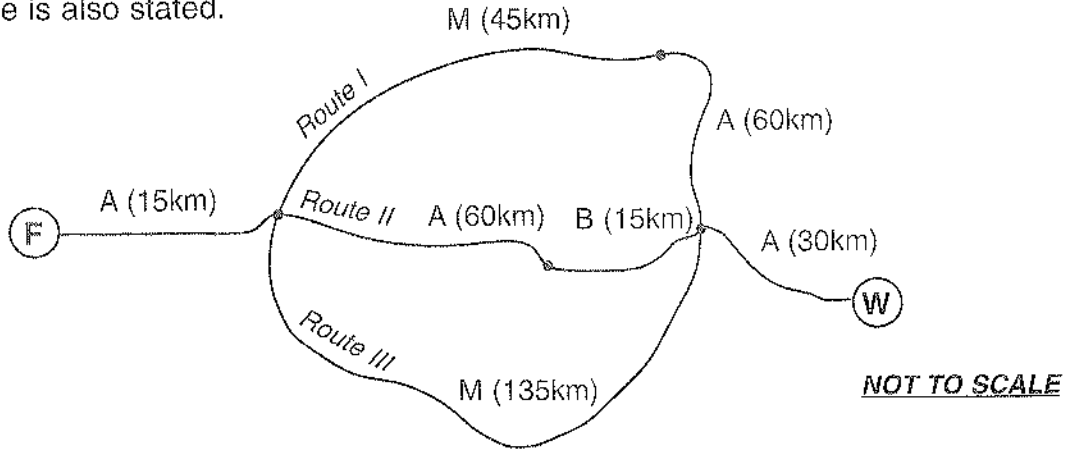

Peter expects to travel at 90km/h on the motorway, 60km/h on the main road and 45km/h on the minor road.

(a) What is the total distance from factory (F) to warehouse (W) following route II?

.....km

(b) What is the total distance of the *longest* route from factory (F) to warehouse (W)?

.....km

(c) How long, in minutes, will it take Peter to travel the first 15km on the main road from the factory (F)?

.....
minutes

(d) How long, in minutes, will it take Peter to travel 45km on the motorway (on route I)?

.....
minutes

(e) How long, in hours and minutes, will it take Peter to complete the whole of route II?

.....
hours

.....
minutes

R
W
(5)

11

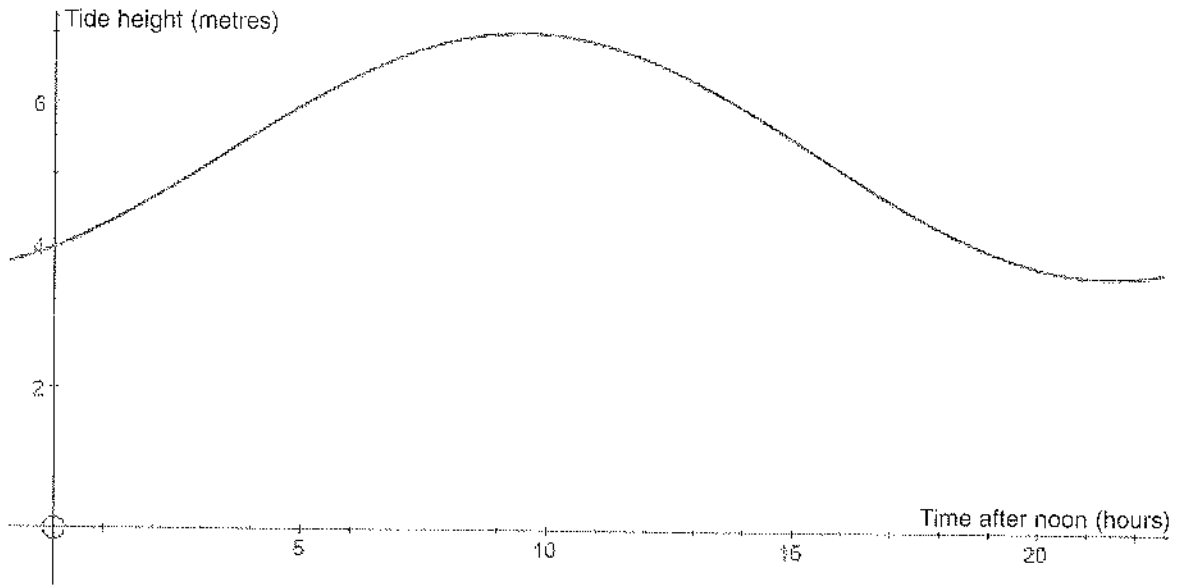

The graph shows the height of the tide, measured in metres, starting at noon.

(a) What is the greatest height that the tide reaches?

(b) At what clock time does the tide drop below 4 metres?

(c) For how many hours is the tide above 6 metres?

12

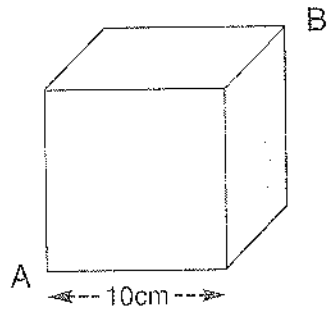

The diagram shows a cube with edges that are each 10cm long.
 An ant is crawling along the edges of the cube from A to B.

(a) How many edges in total does a cube have?

(b) What is the least distance the ant must travel to crawl from A to B, along the edges of the cube?

(c) The ant repeatedly crawls from A to B using a different route each time, but always travels the least possible distance. How many different routes does the ant choose from?

Question (and working space)

ANSWER

Please do not write in this space

E Adrian has a set of 50 raffle tickets, with values from one to fifty.

Beth buys a raffle ticket hoping for a prize.

For each statement in this question, write your answer as 'true' or 'false'.

(a) Beth is more likely to have an odd numbered ticket than an even numbered ticket.

True or false?

(b) Beth is more likely to have a prime numbered ticket than a multiple of 7.

True or false?

(c) Beth is more likely to have a prime numbered ticket than a factor of 50.

True or false?

END OF TEST (You should have completed 13 questions.)

R
W

(3)

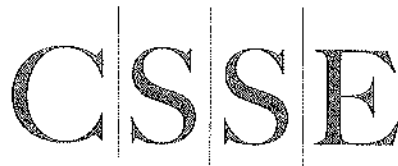

The Consortium of Selective Schools in Essex

All rights reserved, including translation. No part of this publication may be reproduced or transmitted in any form or by any means, electronic or mechanical, including photocopying, recording or duplication in any information storage and retrieval system, without permission in writing from CSSE, and may not be photocopied or otherwise reproduced with the terms of any licence granted by the Copyright Licensing Agency Ltd.

Copyright © The Consortium of Selective Schools in Essex, 2015.

Published by The Consortium of Selective Schools in Essex,
P.O. Box 3087, Chelmsford, Essex CM1 3SY.
