

Please check the examination details below before entering your candidate information

Candidate surname					Other names				
Centre Number					Candidate Number				
<input type="text"/>	<input type="text"/>	<input type="text"/>	<input type="text"/>	<input type="text"/>	<input type="text"/>	<input type="text"/>	<input type="text"/>	<input type="text"/>	<input type="text"/>

Pearson Edexcel Level 1/Level 2 GCSE (9–1)

Time 1 hour 30 minutes

Paper
reference**1MA1/2H**

Mathematics

PAPER 2 (Calculator)

Higher Tier

You must have: Ruler graduated in centimetres and millimetres, protractor, pair of compasses, pen, HB pencil, eraser, calculator, Formulae Sheet (enclosed). Tracing paper may be used.

Total Marks

Instructions

- Use **black** ink or ball-point pen.
- **Fill in the boxes** at the top of this page with your name, centre number and candidate number.
- Answer **all** questions.
- Answer the questions in the spaces provided – *there may be more space than you need.*
- You must **show all your working**.
- Diagrams are **NOT** accurately drawn, unless otherwise indicated.
- **Calculators may be used.**
- If your calculator does not have a π button, take the value of π to be 3.142 unless the question instructs otherwise.



Information

- The total mark for this paper is 80
- The marks for **each** question are shown in brackets – *use this as a guide as to how much time to spend on each question.*

Advice

- Read each question carefully before you start to answer it.
- Try to answer every question.
- Check your answers if you have time at the end.

Turn over ►

P68723A

©2022 Pearson Education Ltd.

B:1/1/1/1/1/1/



Pearson

MME. GCSE Revision - GCSE Maths

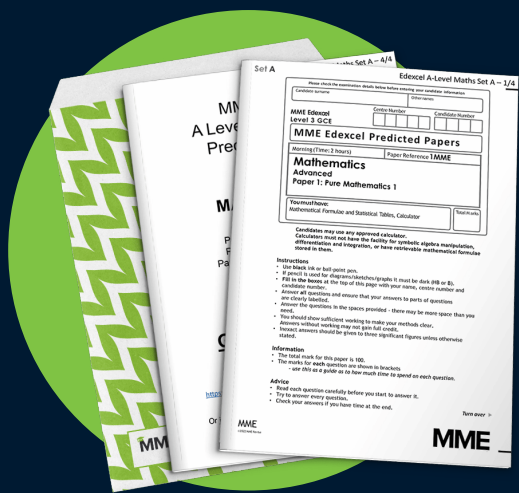

GCSE Maths Predicted Papers 2024

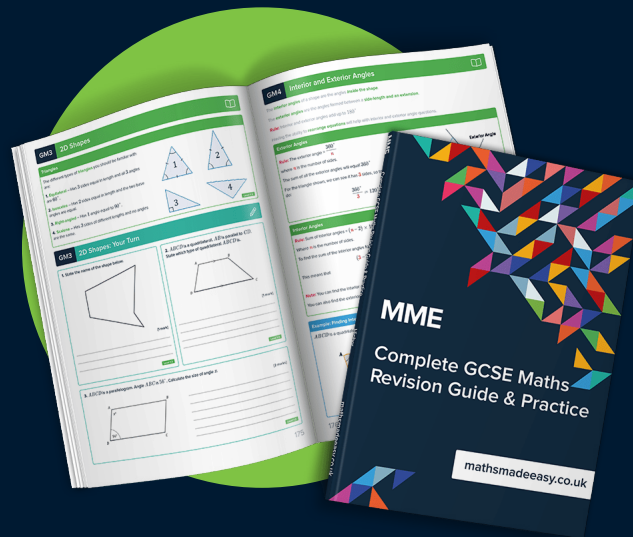

GCSE Maths Revision Guide



GCSE Maths Revision Cards



Course in a Box – GCSE Maths (Guaranteed Pass)

[View All GCSE Maths](#)

mathsmadeeasy.co.uk

Answer ALL questions.

Write your answers in the spaces provided.

You must write down all the stages in your working.

- 1 The scatter graph shows information about the amount of rainfall, in mm, and the number of hours of sunshine for each of ten English towns on the same day.

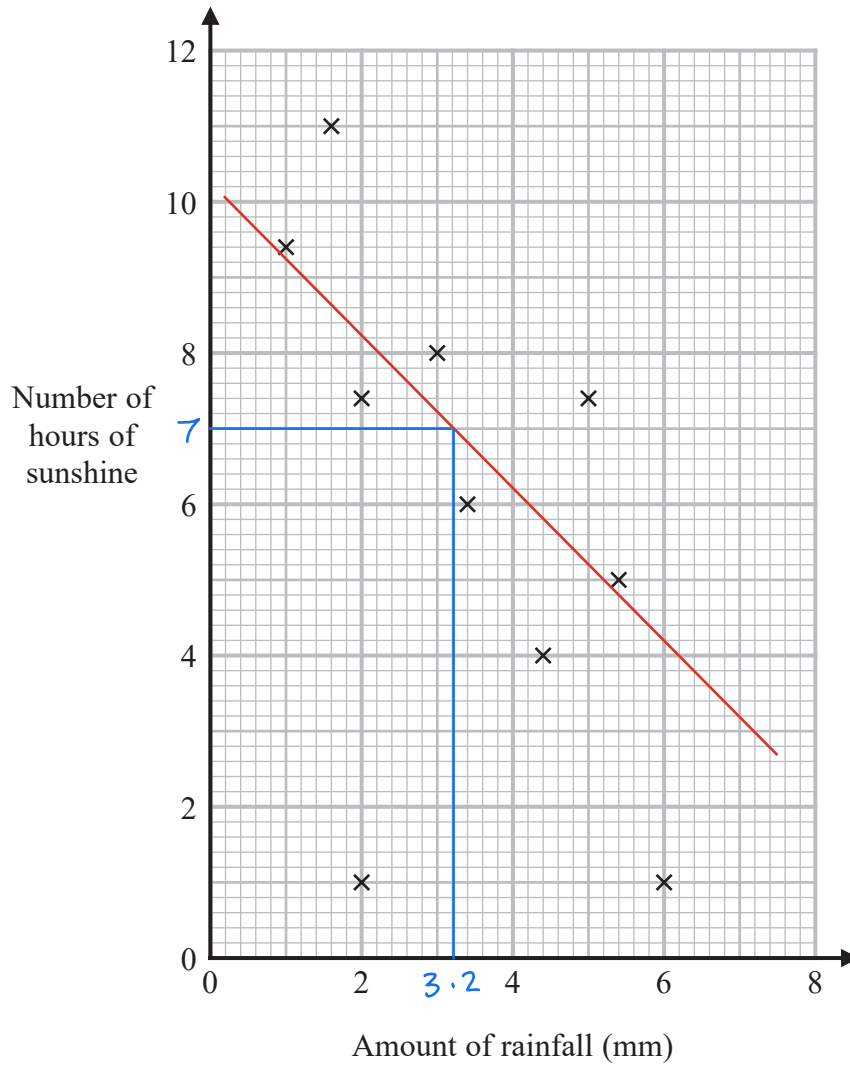

One of the points is an outlier.

- (a) Write down the coordinates of this point.

(2 , 1)
(1)



DO NOT WRITE IN THIS AREA

DO NOT WRITE IN THIS AREA

DO NOT WRITE IN THIS AREA

- (b) Ignoring the outlier, describe the relationship between the amount of rainfall and the number of hours of sunshine.

As the amount of rainfall decreases, the number of hours of sunshine increases.

(1)

On the same day in another English town there were 7 hours of sunshine.

- (c) Using the scatter graph, estimate the amount of rainfall in this town on this day.

3.2 mm

(2)

(Total for Question 1 is 4 marks)

DO NOT WRITE IN THIS AREA

DO NOT WRITE IN THIS AREA

DO NOT WRITE IN THIS AREA



2 The front elevation and the plan of a solid are shown on the grid.

On the grid, draw the side elevation of the solid from the direction of the arrow.

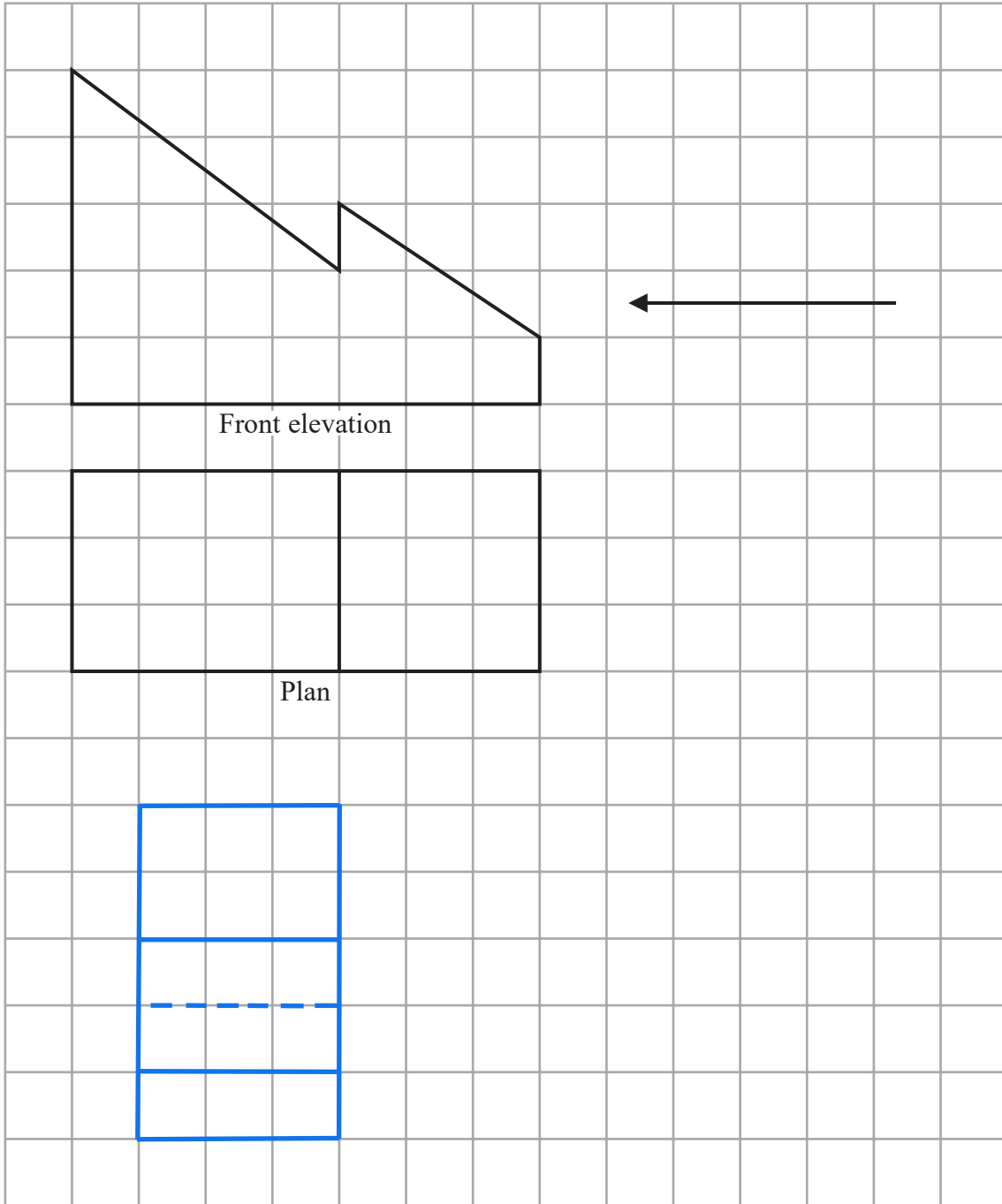

(Total for Question 2 is 2 marks)

DO NOT WRITE IN THIS AREA

DO NOT WRITE IN THIS AREA

DO NOT WRITE IN THIS AREA



- 3 Here are the first five terms of an arithmetic sequence.

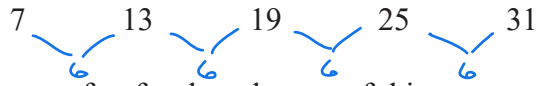

- (a) Find an expression, in terms of n , for the n th term of this sequence.

First difference is 6 so must start with $6n$

$6n$ would give sequence 6 12 18 24 30

need +1 for each term so must be $6n+1$

$$\underline{6n+1}$$

(2)

The n th term of a different sequence is $8 - 6n$

- (b) Is -58 a term of this sequence?

You must show how you get your answer.

Try $8 - 6n = -58$

$$-6n = -66$$

$$n = 11 \leftarrow \text{yes, } -58 \text{ is the } 11^{\text{th}} \text{ term}$$

(2)

(Total for Question 3 is 4 marks)



4 The diagram shows a plan of Jason's garden.

$ABCO$ and $DEFO$ are rectangles.

CDO is a right-angled triangle.

AFO is a sector of a circle with centre O and angle $AOF = 90^\circ$

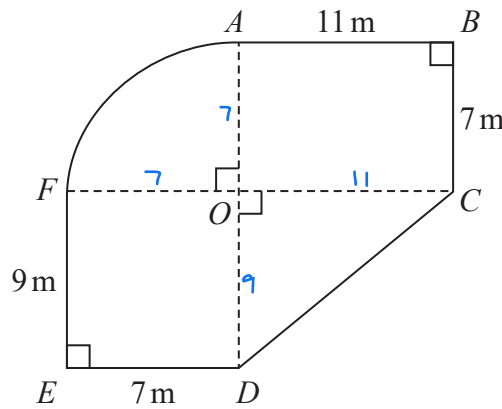

Jason is going to cover his garden with grass seed.

Each bag of grass seed covers 14m^2 of garden.

Each bag of grass seed costs £10.95

Work out how much it will cost Jason to buy all the bags of grass seed he needs.

$$\begin{aligned} \text{Area of rectangles} &= (9 \times 7) + (11 \times 7) \\ &= 63 + 77 \\ &= 140\text{m}^2 \end{aligned}$$

$$\begin{aligned} \text{Area of triangle} &= \frac{7 \times 11}{2} \\ &= 49.5\text{m}^2 \end{aligned}$$

$$\text{Area of quarter circle} = \frac{\pi \times 7^2}{4} = \frac{49\pi}{4}$$

$$\begin{aligned} \text{Total area} &= 140 + 49.5 + \frac{49\pi}{4} \\ &= 227.98451 \end{aligned}$$

needs $227.98451 \div 14 = 16.28$ bags, so 17 whole bags

costs $17 \times \pounds 10.95 = \pounds 186.15$

£ 186.15

(Total for Question 4 is 5 marks)



5

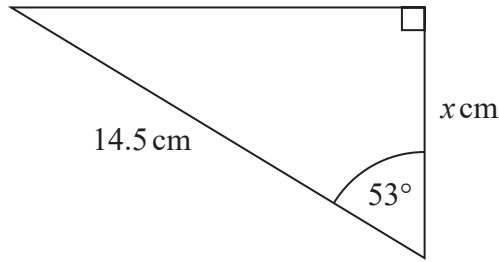

Work out the value of x .

Give your answer correct to 3 significant figures.

$$\cos 53 = \frac{x}{14.5}$$

$$\cos 53 \times 14.5 = x$$

$$8.73 = x$$

$$x = 8.73$$

(Total for Question 5 is 2 marks)

- 6 Ella invests £7000 for 2 years in an account paying compound interest.

In the first year, the rate of interest is 3% — $100\% + 3\% = 103\% = 1.03$

In the second year, the rate of interest is 1.5% — $100\% + 1.5\% = 101.5\% = 1.015$

Work out the value of Ella's investment at the end of 2 years.

$$£7000 \times 1.03 \times 1.015 = £7318.15$$

$$£ 7318.15$$

(Total for Question 6 is 3 marks)



7 Here is the graph of $y = x^2 - 6x + 4$

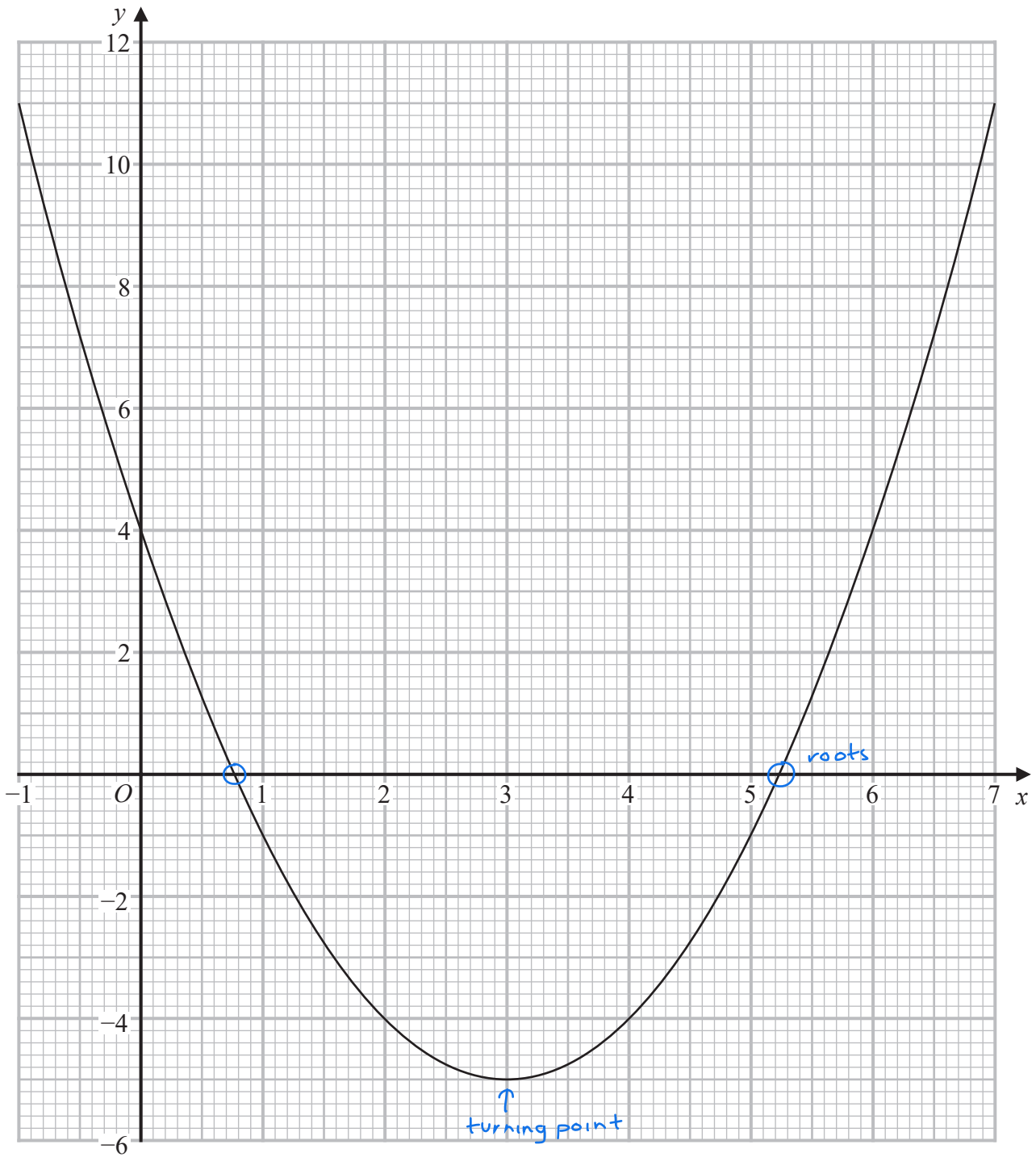

DO NOT WRITE IN THIS AREA

DO NOT WRITE IN THIS AREA

DO NOT WRITE IN THIS AREA



(a) Write down the y intercept of the graph of $y = x^2 - 6x + 4$

4

(1)

(b) Write down the coordinates of the turning point of the graph of $y = x^2 - 6x + 4$

(3 , -5)

(1)

(c) Use the graph to find estimates for the roots of $x^2 - 6x + 4 = 0$

0.8 , 5.2

(2)

(Total for Question 7 is 4 marks)

DO NOT WRITE IN THIS AREA

DO NOT WRITE IN THIS AREA

DO NOT WRITE IN THIS AREA



P 6 8 7 2 3 A 0 9 2 4

- 8 Chanda buys a necklace for £120
She sells the necklace for £135

Work out her percentage profit.

$$\frac{135 - 120}{120} \times 100 = 12.5\%$$

..... 12.5%

(Total for Question 8 is 3 marks)

- 9 Here are the equations of two straight lines.

$$y = \frac{1}{2}x - 6$$

$$6y = 3x + 7$$

Oscar says that these lines are parallel.

Is Oscar correct?

You must give a reason for your answer.

$$y = \left(\frac{1}{2}\right)x - 6$$

gradient $\frac{1}{2}$

$$6y = 3x + 7 \quad \downarrow \div 6$$

$$y = \left(\frac{1}{2}\right)x + \frac{7}{6}$$

gradient $\frac{1}{2}$

Both have gradient $\frac{1}{2}$ so yes, they are parallel.

(Total for Question 9 is 2 marks)

DO NOT WRITE IN THIS AREA

DO NOT WRITE IN THIS AREA

DO NOT WRITE IN THIS AREA



10 Aaliyah bought a car.

In the first year after she bought the car, its value depreciated at a rate of 23% per annum.

In the second year after she bought the car, its value depreciated at a rate of 19% per annum.

At the end of the second year the car was worth £10914.75

What was the value of the car when Aaliyah bought it?

$$100\% - 23\% = 77\%$$

$$= 0.77$$

$$100\% - 19\% = 81\%$$

$$= 0.81$$

$$£10914.75 \div 0.81 \div 0.77 = £17,500$$

£ 17,500

(Total for Question 10 is 3 marks)



11 In an experiment, 60 students each completed a puzzle.

The cumulative frequency graph shows information about the times taken for the 60 students to complete the puzzle.

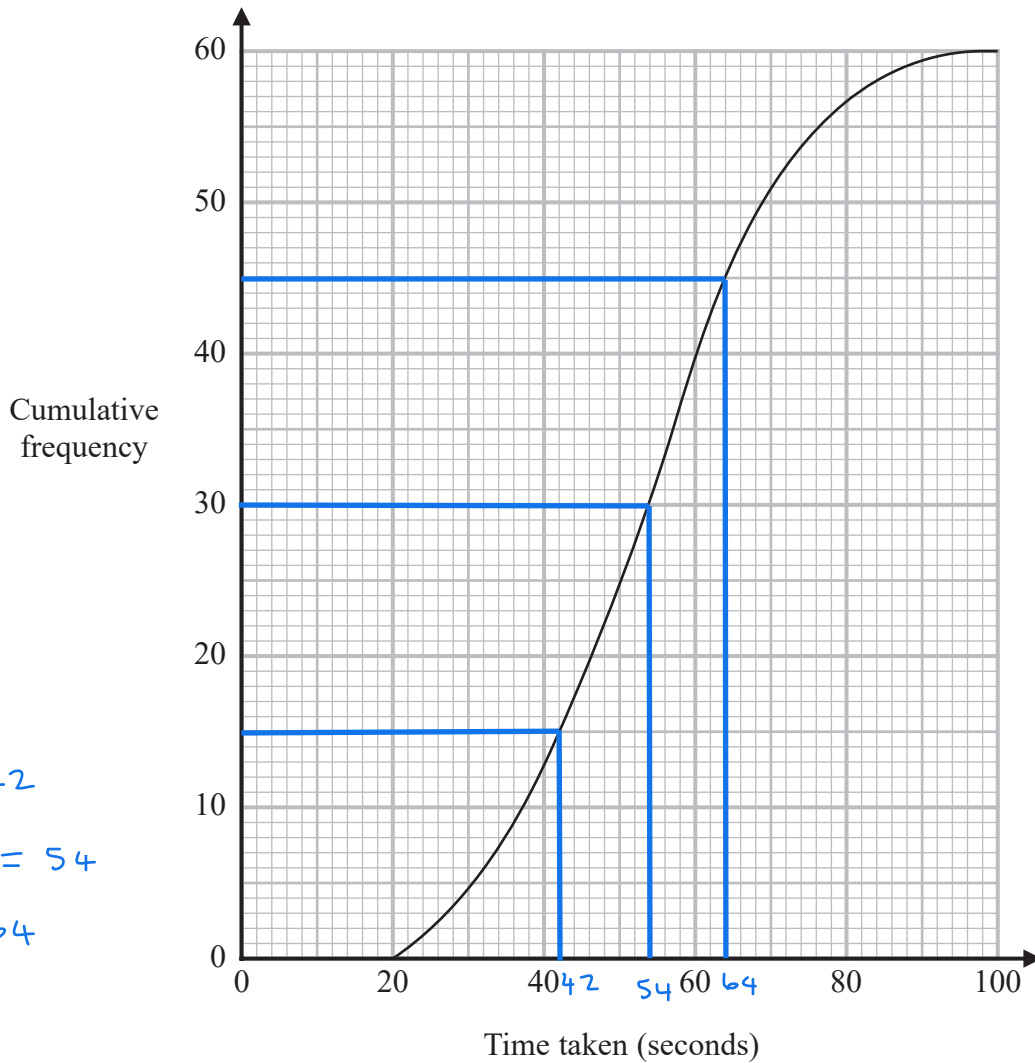

LQ = 42
median = 54
UQ = 64

For these 60 students,

- the least time taken was 24 seconds
- the greatest time taken was 96 seconds.

On the grid below, draw a box plot for the distribution of the times taken by the students.

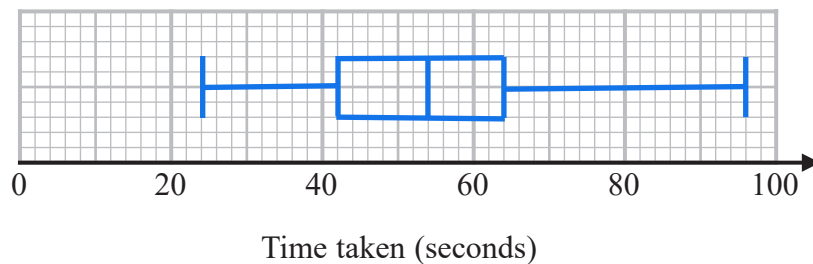

(Total for Question 11 is 3 marks)



DO NOT WRITE IN THIS AREA

DO NOT WRITE IN THIS AREA

DO NOT WRITE IN THIS AREA

DO NOT WRITE IN THIS AREA

DO NOT WRITE IN THIS AREA

DO NOT WRITE IN THIS AREA

12 The number of insects in a population at the start of the year n is P_n

The number of insects in the population at the start of year $(n + 1)$ is P_{n+1} where

$$P_{n+1} = kP_n$$

Given that k has a constant value of 1.13

- (a) find out how many years it takes for the number of insects in the population to double.
You must show how you get your answer.

$P_{n+1} = 1.13 P_n$ so new population is always 1.3 x the population the previous year. How many times do we need to multiply by 1.13 to get to double the original population?

$$1.13^2 = 1.2769$$

$$1.13^3 = 1.4428...$$

$$1.13^4 = 1.630...$$

$$1.13^5 = 1.842...$$

$$1.13^6 = 2.08...$$

so 6 years to get over twice original population

6

(2)

The value of k actually increases year on year from its value of 1.13 in year 1

- (b) How does this affect your answer to part (a)?

It will decrease

(1)

(Total for Question 12 is 3 marks)



- 13 A and B are points on a centimetre grid.
 A is the point with coordinates $(-7, 6)$
 B is the point with coordinates $(8, -5)$

Work out the length of AB .
 Give your answer correct to 1 decimal place.

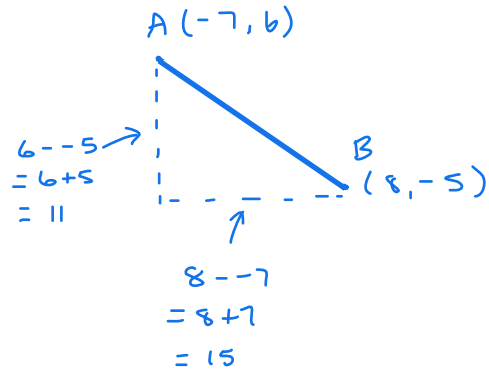

By Pythagoras, $AB^2 = 11^2 + 15^2$
 $AB^2 = 346$
 $AB = \sqrt{346}$
 $AB = 18.601... \text{ cm}$

..... 18.6 cm

(Total for Question 13 is 2 marks)

- 14 Using algebra, prove that $1.0\dot{6}\dot{2}$ can be written as $1 \frac{14}{225}$

Say $x = 1.0622222 \dots$

$100x = 106.22222 \dots$

$1000x = 1062.22222 \dots$

Subtracting, $900x = 1062 - 106$

$900x = 956$

$x = \frac{956}{900}$ ↘ ÷ 4

$= \frac{239}{225}$

$= 1 \frac{14}{225}$

(Total for Question 14 is 3 marks)



DO NOT WRITE IN THIS AREA

DO NOT WRITE IN THIS AREA

DO NOT WRITE IN THIS AREA

15 Faiza is studying the population of rabbits in a park.
She wants to estimate the number of rabbits in the park.

On Monday she catches a random sample of 20 rabbits in the park, marks each rabbit with a tag and releases them back into the park.

On Tuesday she catches a random sample of 42 rabbits in the park.
12 of the rabbits are marked with a tag.

(a) Find an estimate for the number of rabbits in the park.

$\frac{12}{20}$ from Monday are caught on Tuesday

$\frac{42}{n}$ are caught on Tuesday, where n is whole population

so $\frac{12}{20} = \frac{42}{n}$

$\frac{20}{12} = \frac{n}{42}$ so $n = \frac{20}{12} \times 42 = 70$ rabbits in park

..... 70
(3)

Albie is studying the population of rabbits in a wood.

One day, he catches 55 rabbits and finds that 40 of these rabbits are marked with a tag.

Albie estimates there are 50 rabbits in the wood.

(b) Explain why Albie's estimate cannot be correct.

He catches 55 rabbits, so there must be at least 55 in the woods

.....
.....
.....
(1)

(Total for Question 15 is 4 marks)



16 The shaded region shown on the grid is bounded by four straight lines.

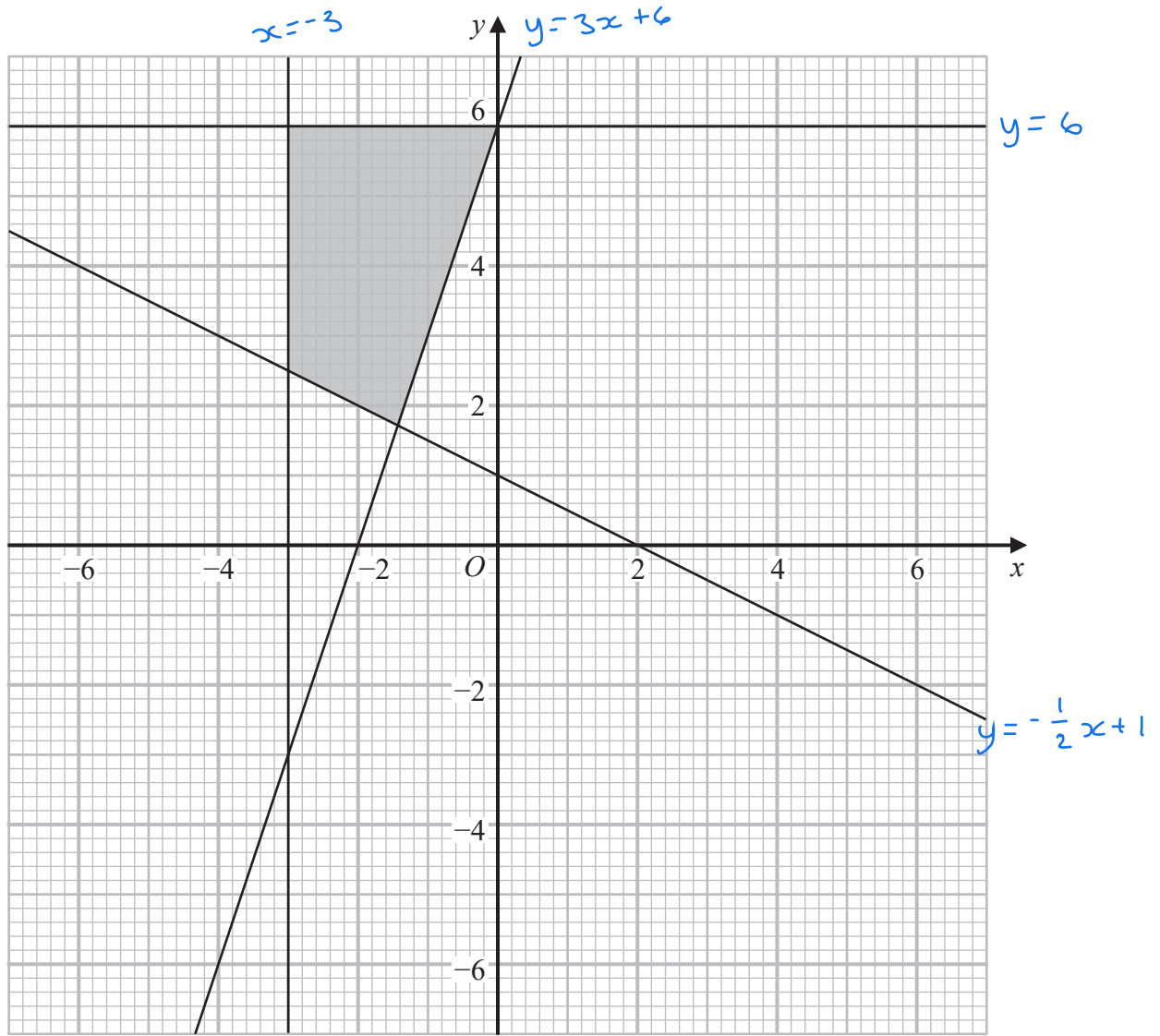

Find the four inequalities that define the shaded region.

$$y \geq 3x + 6$$

$$x \geq -3$$

$$y \geq -\frac{1}{2}x + 1$$

$$y \leq 6$$

(Total for Question 16 is 4 marks)



DO NOT WRITE IN THIS AREA

DO NOT WRITE IN THIS AREA

DO NOT WRITE IN THIS AREA

17 The diagram shows two similar solid triangular prisms, **A** and **B**.

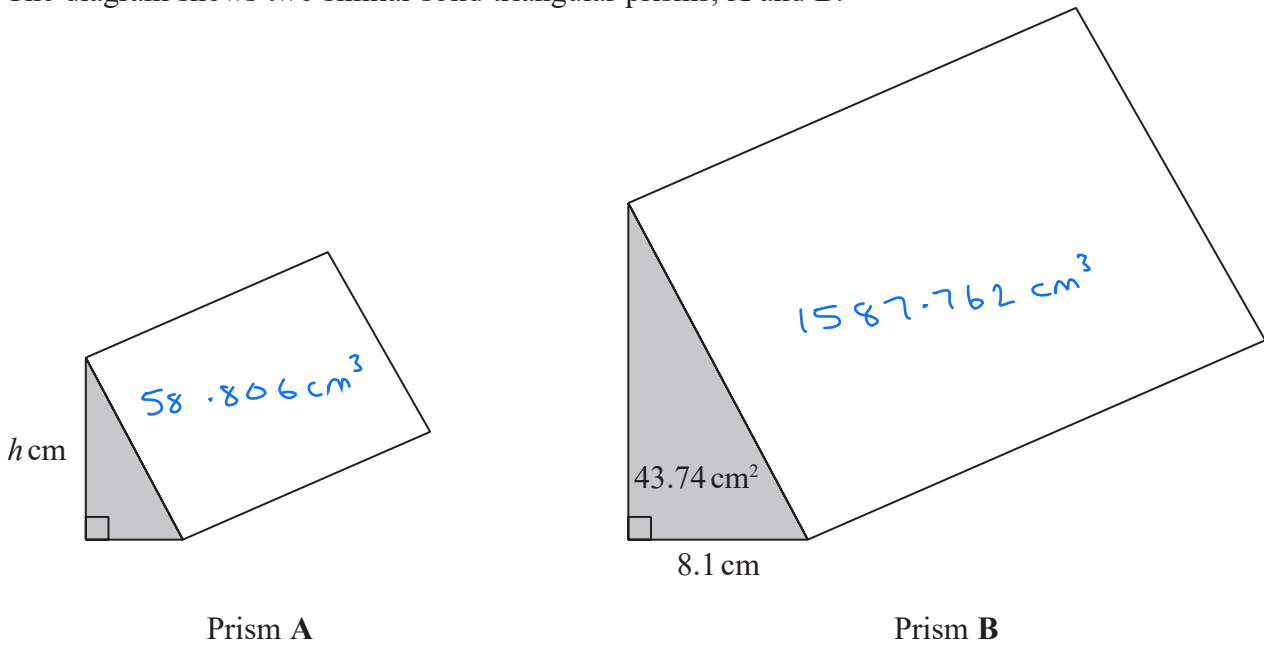

The volume of prism **A** is 58.806 cm^3
 The volume of prism **B** is 1587.762 cm^3

The cross section of each prism is a right-angled triangle.

For prism **B**
 the length of the base of the triangle is 8.1 cm
 the area of the triangle is 43.74 cm^2

The height of the triangle for prism **A** is $h \text{ cm}$.

Work out the value of h .

$$\text{Volume scale factor is } 1587.762 \div 58.806 = 27$$

$$\text{length scale factor is } \sqrt[3]{27} = 3$$

$$\text{Find height of triangle on prism B : } \frac{\text{height} \times 8.1}{2} = 43.74$$

$$\text{height} = \frac{43.74 \times 2}{8.1} = 10.8$$

$$\text{So height of prism A is } 10.8 \div 3 = 3.6 \text{ cm}$$

$$h = 3.6$$

(Total for Question 17 is 4 marks)

18 Here is a triangle.

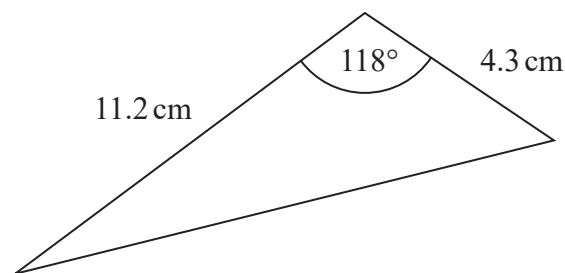

Work out the area of the triangle.

Give your answer correct to 3 significant figures.

$$\begin{aligned} \text{Area} &= \frac{1}{2} \times 11.2 \times 4.3 \times \sin 118 \\ &= 21.3 \text{ cm}^2 \text{ (3sf)} \end{aligned}$$

..... 21.3 cm²

(Total for Question 18 is 2 marks)

19 Solve $6x^2 + 5x - 6 = 0$

$$(2x + 3)(3x - 2) = 0$$

$$2x + 3 = 0 \quad \text{or} \quad 3x - 2 = 0$$

$$2x = -3$$

$$3x = 2$$

$$x = -\frac{3}{2}$$

$$x = \frac{2}{3}$$

..... $x = -\frac{3}{2}, x = \frac{2}{3}$

(Total for Question 19 is 3 marks)



20 $ABCDEFGH$ is a cuboid.

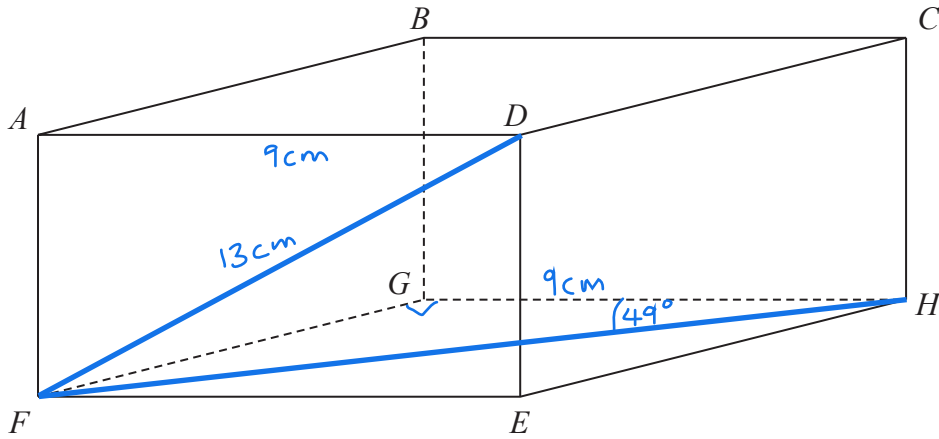

$AD = 9\text{ cm}$
 $FD = 13\text{ cm}$
 Angle $GHF = 49^\circ$

Work out the size of angle FAH .
 Give your answer correct to the nearest degree.

By Pythagoras, $AF^2 = 13^2 - 9^2$
 $AF^2 = 88$
 $AF = \sqrt{88}$

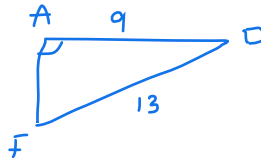

Using trigonometry, $\cos 49 = \frac{9}{FH}$

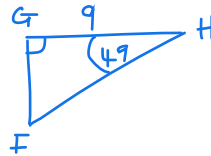

$$FH = \frac{9}{\cos 49}$$

$$FH = 13.71827\dots$$

Using trigonometry again, $\tan FAH = \frac{13.71827\dots}{\sqrt{88}}$

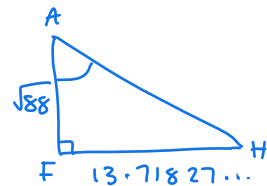

$$FAH = \tan^{-1} \left(\frac{13.71827\dots}{\sqrt{88}} \right)$$

$$= 55.63\dots^\circ$$

$$= 56^\circ \text{ to nearest degree}$$

..... 56°

(Total for Question 20 is 4 marks)

DO NOT WRITE IN THIS AREA



21 The graph below gives the volume, in litres, of water in a container t seconds after the water starts to fill the container.

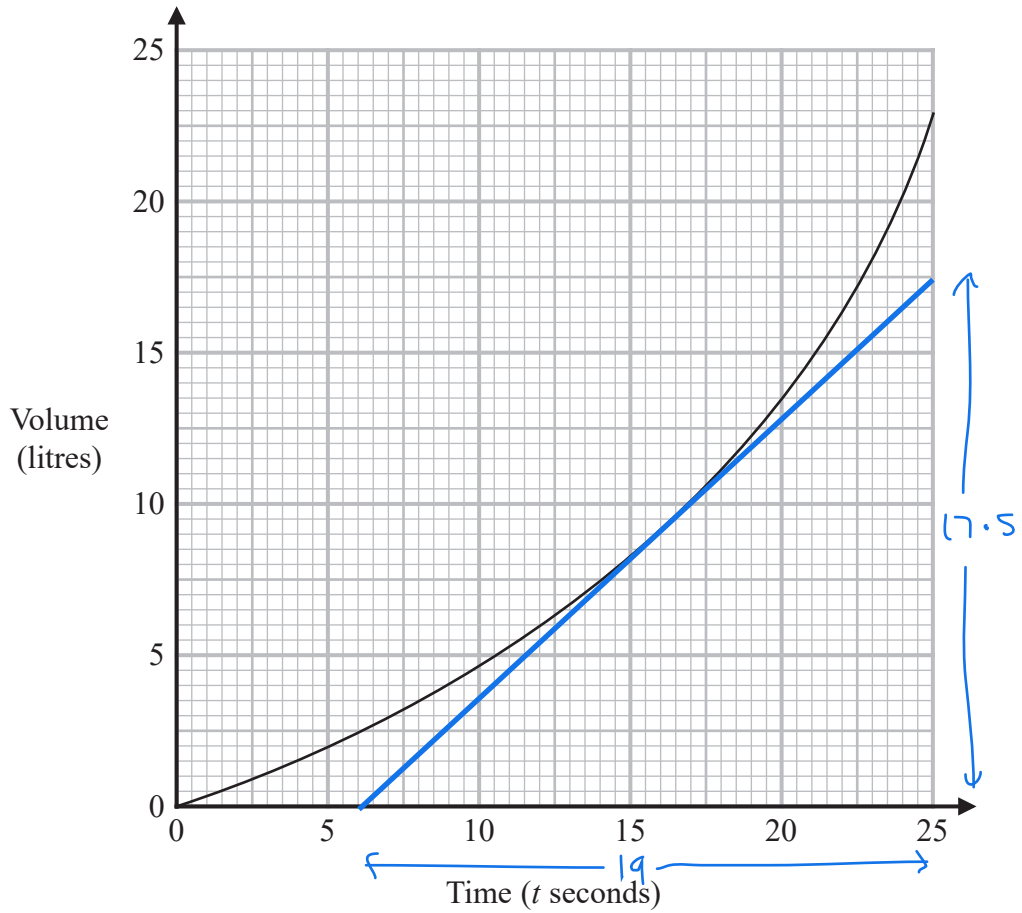

- (a) Calculate an estimate for the gradient of the graph when $t = 17.5$
You must show how you get your answer.

$$\begin{aligned} \text{gradient} &= 17.5 \div 19 \\ &= 0.92 \end{aligned}$$

0.92
(3)

- (b) Describe fully what the gradient in part (a) represents.

Rate of change of volume

(1)

(Total for Question 21 is 4 marks)

DO NOT WRITE IN THIS AREA

DO NOT WRITE IN THIS AREA

DO NOT WRITE IN THIS AREA



22 $f(x) = \sqrt[3]{x}$
 $g(x) = 2x + 3$

$$h(x) = fg(x)$$

Find $h^{-1}(x)$

$$\begin{aligned} h(x) &= f(g(x)) \\ &= \sqrt[3]{2x+3} \end{aligned}$$

Say $y = \sqrt[3]{2x+3}$

$$y^3 = 2x + 3$$

$$y^3 - 3 = 2x$$

$$\frac{y^3 - 3}{2} = x$$

$$\text{so } h^{-1}(x) = \frac{x^3 - 3}{2}$$

$$h^{-1}(x) = \frac{x^3 - 3}{2}$$

(Total for Question 22 is 3 marks)



23 A race is measured to have a distance of 10.6 km, correct to the nearest 0.1 km.
Sam runs the race in a time of 31 minutes 48 seconds, correct to the nearest second.

Sam's average speed in this race is V km/hour.



By considering bounds, calculate the value of V to a suitable degree of accuracy.
You must show all your working and give a reason for your answer.

$$10.6 \text{ km} \begin{cases} 10.55 \\ 10.65 \end{cases}$$

$$31 \text{ min } 48 \text{ sec} = (31 \times 60) + 48 \text{ sec} = 1908 \text{ sec} \begin{cases} 1907.5 \\ 1908.5 \end{cases}$$

$$1907.5 \div 60 \div 60 = 0.529861... \text{ hrs}$$

$$1908.5 \div 60 \div 60 = 0.530138... \text{ hrs}$$

$$\begin{aligned} \text{max speed} &= \frac{\text{max distance}}{\text{min time}} \\ &= \frac{10.65}{0.529861...} \\ &= 20.099 \text{ km/h} \end{aligned}$$

$$\begin{aligned} \text{min speed} &= \frac{\text{min distance}}{\text{max time}} \\ &= \frac{10.55}{0.530138...} \\ &= 19.900 \text{ km/h} \end{aligned}$$

So 20 km/h to 2 significant figures as both bounds agree

(Total for Question 23 is 5 marks)

DO NOT WRITE IN THIS AREA

DO NOT WRITE IN THIS AREA

DO NOT WRITE IN THIS AREA



24 A circle has equation $x^2 + y^2 = 12.25$

The point P lies on the circle.

The coordinates of P are $(2.1, 2.8)$

The line L is the tangent to the circle at point P .

Find an equation of L .

Give your answer in the form $ax + by = c$, where a , b and c are integers.

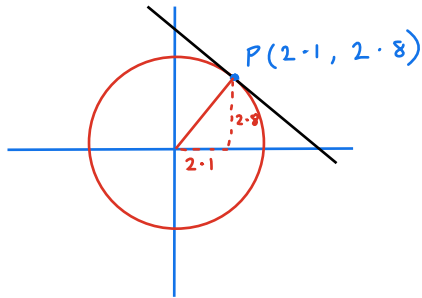

$$\text{gradient of radius} = \frac{2.8}{2.1} = \frac{4}{3}$$

tangent is perpendicular to radius, so gradients multiply to make -1

$$\text{so gradient of tangent is } -\frac{3}{4}$$

$$\text{so tangent is of the form } y = -\frac{3}{4}x + c$$

through $(2.1, 2.8)$ so

$$2.8 = -\frac{3}{4} \times 2.1 + c$$

$$2.8 = -\frac{6.3}{4} + c$$

$$c = \frac{3.5}{8}$$

$$\text{so tangent is } y = -\frac{3}{4}x + \frac{3.5}{8}$$

$$8y = -6x + 3.5$$

$$6x + 8y = 3.5$$

$$\underline{\underline{6x + 8y = 35}}$$

(Total for Question 24 is 4 marks)

TOTAL FOR PAPER IS 80 MARKS

