

Surname	Centre Number	Candidate Number
First name(s)		0



GCSE

C300U20-1



WEDNESDAY, 7 JUNE 2023 – MORNING

MATHEMATICS – Component 2
Calculator-Allowed Mathematics
FOUNDATION TIER

2 hours 15 minutes

ADDITIONAL MATERIALS

- An additional formulae sheet.
- A calculator will be required for this examination.
- A ruler, protractor and a pair of compasses may be required.

INSTRUCTIONS TO CANDIDATES

- Use black ink or black ball-point pen.
- Do not use gel pen or correction fluid.
- You may use a pencil for graphs and diagrams only.
- Write your name, centre number and candidate number in the spaces at the top of this page.
- Answer **all** the questions in the spaces provided.
- If you run out of space, use the additional page(s) at the back of the booklet, taking care to number the question(s) correctly.

INFORMATION FOR CANDIDATES

- You should give details of your method of solution when appropriate.
- Unless stated, diagrams are not drawn to scale.
- Scale drawing solutions will not be acceptable where you are asked to calculate.
- The number of marks is given in brackets at the end of each question or part-question.
- You are reminded of the need for good English and orderly, clear presentation in your answers.

For Examiner's use only		
Question	Maximum Mark	Mark Awarded
1.	8	
2.	7	
3.	5	
4.	4	
5.	5	
6.	8	
7.	5	
8.	5	
9.	3	
10.	3	
11.	5	
12.	3	
13.	4	
14.	9	
15.	5	
16.	2	
17.	4	
18.	4	
19.	5	
20.	7	
21.	8	
22.	4	
23.	7	
Total	120	

C300U201
01



JUN23C300U20101

Formula list

Area and volume formulae

Where r is the radius of the sphere or cone, l is the slant height of a cone and h is the perpendicular height of a cone:

$$\text{Curved surface area of a cone} = \pi r l$$

$$\text{Surface area of a sphere} = 4\pi r^2$$

$$\text{Volume of a sphere} = \frac{4}{3}\pi r^3$$

$$\text{Volume of a cone} = \frac{1}{3}\pi r^2 h$$

Kinematics formulae

Where a is constant acceleration, u is initial velocity, v is final velocity, s is displacement from the position when $t = 0$ and t is time taken:

$$v = u + at$$

$$s = ut + \frac{1}{2}at^2$$

$$v^2 = u^2 + 2as$$



1. The table shows the menu at a café.

Menu					
Main Items		Drinks		Snacks	
Roll	£3.60	Tea	£1.20	Packet of crisps	£1
Sandwich	£3.49	Coffee	£1.85	Piece of fruit	60 p
Salad	£4.23	Soft drink	95 p	Cereal bar	86 p

- (a) Lucy buys a cereal bar, a coffee, a salad and a piece of fruit.

Write down the prices for these items in order of cost.
Start with the cheapest.

[2]

.....

.....

.....

Cheapest

- (b) The café offers a Meal Deal.

Buy any main item with a drink and snack for £5.

Jason buys a sandwich. Later he buys a tea and a packet of crisps.

How much **less** would he have paid if he had bought these three items using the Meal Deal?

[2]

.....

.....

- (c) (i) On Monday, Emma buys 8 soft drinks.
What is the total cost for this?

[2]

.....

.....

- (ii) On Tuesday, Emma only buys coffees.
She spends £12.95.
How many coffees does she buy?

[2]

.....

.....



2. (a) Complete the pattern below so that AB is a line of symmetry.

Shade the smallest possible number of squares.

[2]

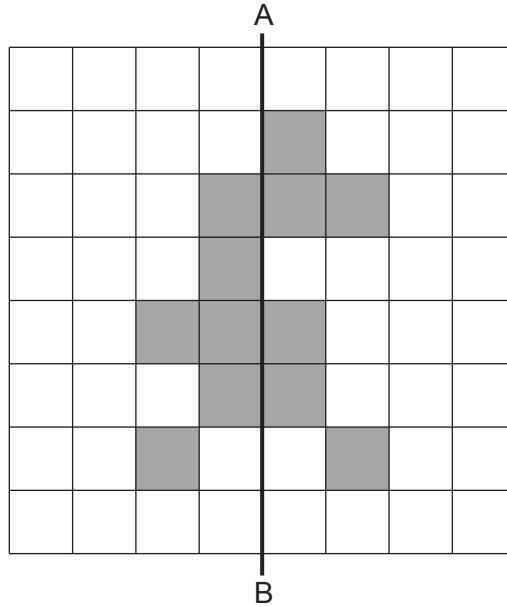

(b) Circle the shape below that has rotational symmetry of order 4.

[1]

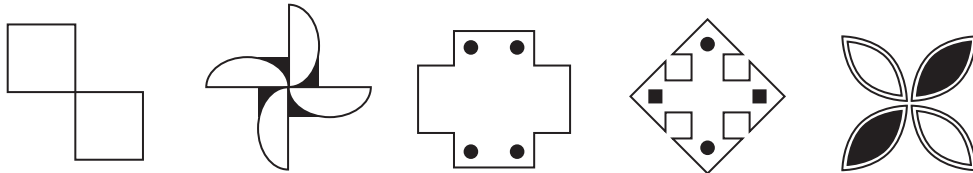

(c) The diagram below shows a triangular prism.

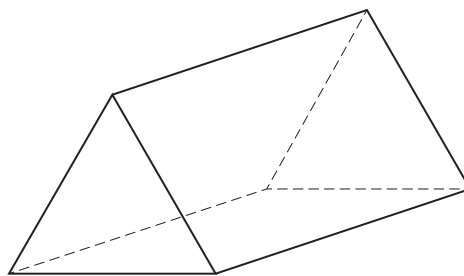

Diagram not drawn to scale

How many edges and vertices does the triangular prism have?

[2]

Edges Vertices



(d) Draw one line to connect each of the following mathematical names to the correct shape.
 You will not need to use every shape. One has been completed for you. [2]

Rectangle

Rhombus

Trapezium

Kite

Hexagon

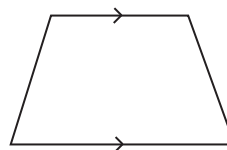
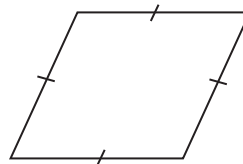
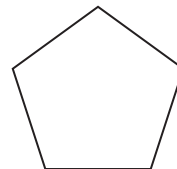
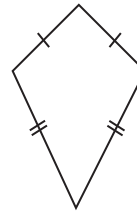
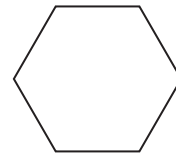
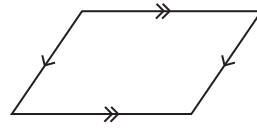

3. (a) Peter uses numbers and a symbol to correctly write,
one seventh is greater than one eighth.

Circle what Peter writes.

[1]

$$\frac{1}{7} \leq \frac{1}{8}$$

$$\frac{1}{7} \geq \frac{1}{8}$$

$$\frac{1}{7} = \frac{1}{8}$$

$$\frac{1}{7} > \frac{1}{8}$$

$$\frac{1}{7} < \frac{1}{8}$$

- (b) A large jar contains 8571 jellybeans.
2857 of the jellybeans in the jar are blue.



Use one of the five options shown below to complete the sentence.

[1]

One fifth

One quarter

One third

One half

Two thirds

..... of the jellybeans in the jar are blue.

.....

.....

.....

- (c) Three of the factors of 18 have a sum of 17.
Write these three factors in the boxes below.

[3]

.....

.....

.....

.....



.....

.....

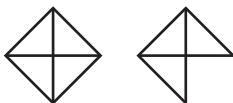
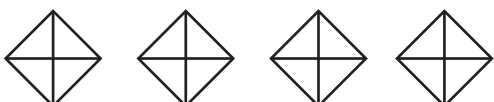

4. Rhys owns a bakery.
He recorded how many cupcakes he sold each day.
The results for the first four days are displayed in the pictogram below.

Key:  represents 12 cupcakes

Monday	
Tuesday	
Wednesday	
Thursday	
Friday	

- (a) Rhys sold 42 cupcakes on Friday.

(i) Complete the pictogram for Friday. [1]

(ii) How many cupcakes did Rhys sell in total from Monday to Friday? [2]

.....
.....

..... cupcakes sold in total from Monday to Friday.

- (b) On Saturday, Rhys sold 17 cupcakes.

Explain why the key used for the pictogram is not suitable to show this. [1]

.....
.....



5. (a) The diagram below shows a number machine.

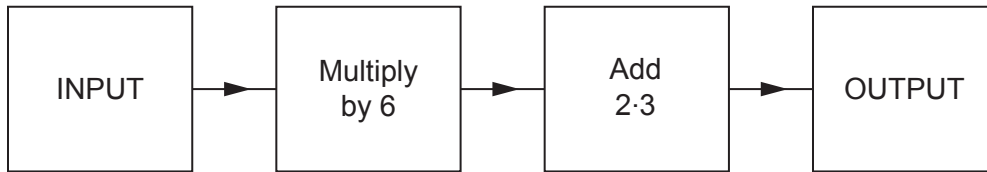

- (i) When the INPUT is 8, what is the OUTPUT? [1]

.....

.....

- (ii) When the OUTPUT is 34.7, what was the INPUT? [1]

.....

.....

- (b) The diagram shows some boxes and some balls on balance scales.

All the boxes have the same mass.
All the balls have the same mass.

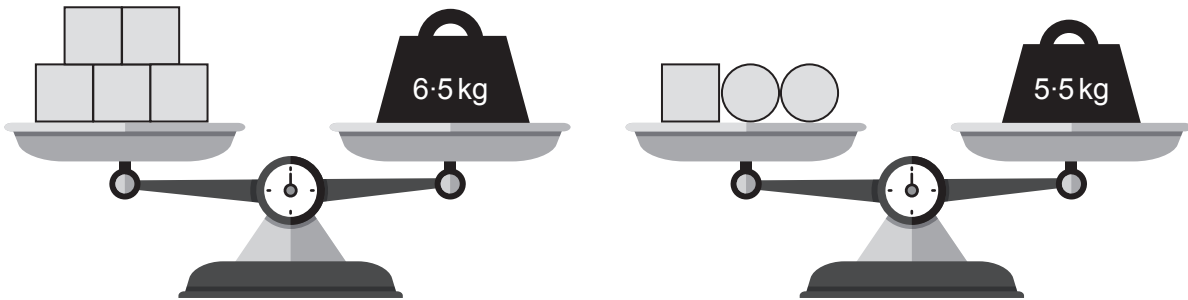

- Calculate the mass of each box and the mass of each ball. [3]

.....

.....

.....

.....

.....

Mass of each box kg

Mass of each ball kg



6. Philip has 250 coins in his money box.

- 22% are £1 coins.
- $\frac{2}{5}$ are 20p coins.
- The rest are 10p coins.



(a) How many £1 coins are there in Philip's money box? [2]

.....

.....

.....

(b) How many 20p coins are there in Philip's money box? [2]

.....

.....

.....

(c) What is the total value of the coins in Philip's money box? [4]

.....

.....

.....

.....

.....

.....



7. Reem has made a scale model of her car.

The diagram below shows the plan view of her model.

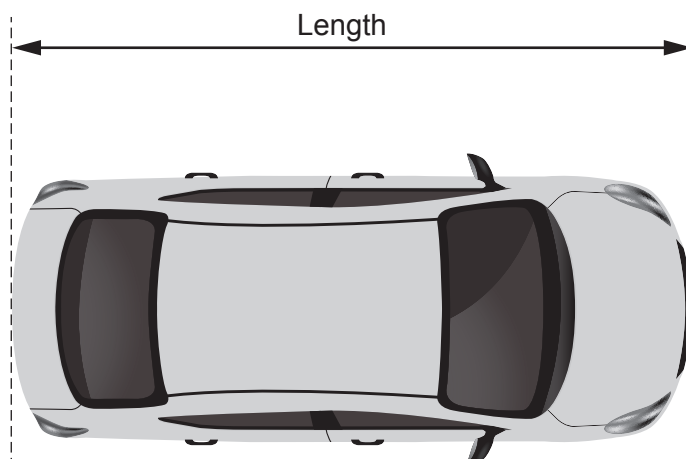

Scale: 1 cm represents $\frac{1}{2}$ metre

- (a) Find the length of Reem's actual car.

[3]

.....

.....

.....

.....

- (b) The height of Reem's actual car is 1.7 m.

Calculate the height of the model car.
Give your answer in cm.

[2]

.....

.....

.....

.....



8. Shazad has six numbered cards.

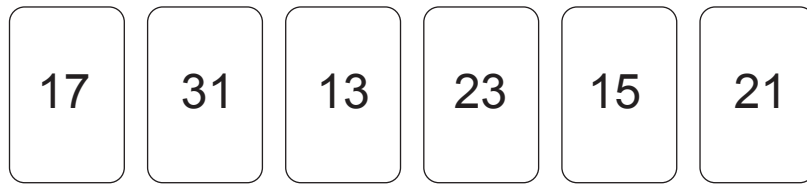

(a) What is the median of the numbers on Shazad's cards?

[2]

.....

.....

.....

.....

(b) Liz says,

"I can pick five of Shazad's cards that have a mean of 21."

Which five cards must Liz pick for her statement to be correct?
You must show all your working.

[3]

.....

.....

.....

.....

.....

.....

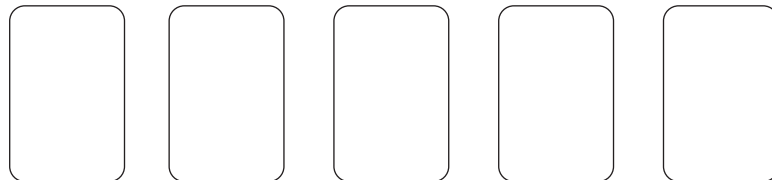

9. The diagram shows three **identical** squares.

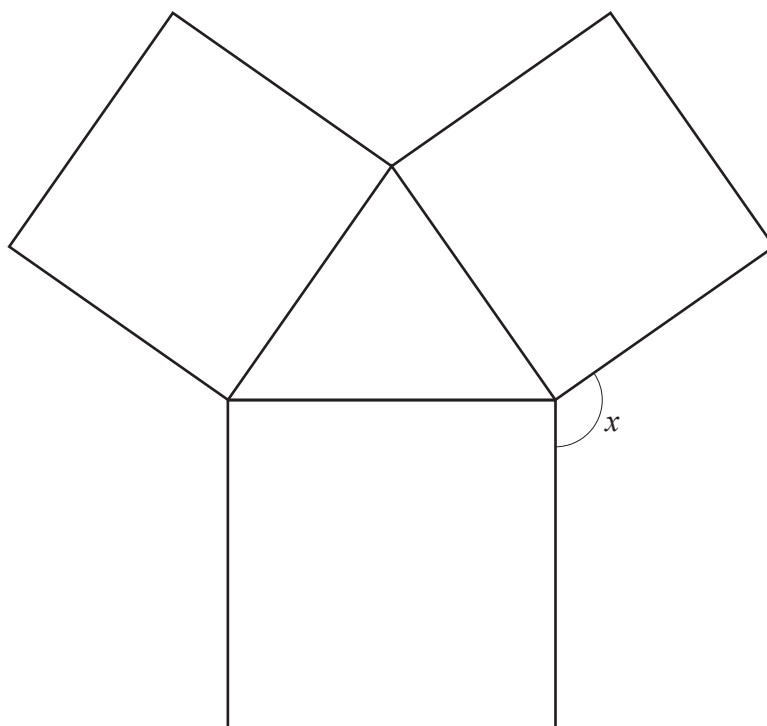

Diagram not drawn to scale

Calculate the size of angle x .

[3]

.....

.....

.....

.....

.....

$$x = \text{.....}^\circ$$



10. The conversion graph below may be used to change between distances in miles and distances in kilometres.

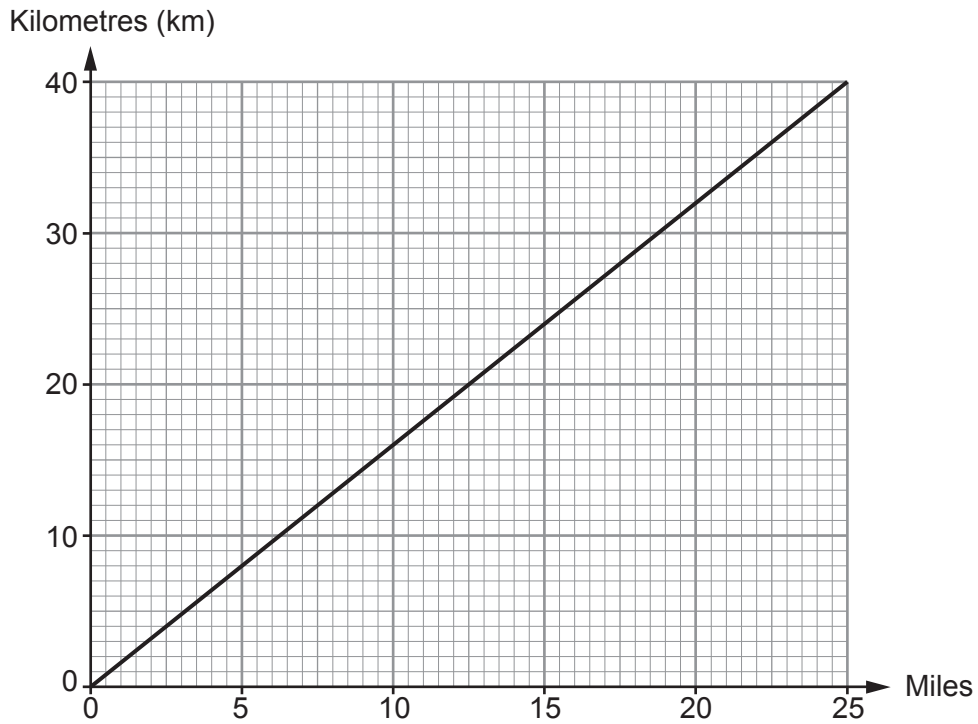

Use the graph to answer the following questions.

- (a) Aaron and Jenny both went for a run.
Aaron ran 28 km and Jenny ran 15 miles.

Who ran the longer distance?

Aaron Jenny

Show how you decide.

[1]

.....

.....

- (b) Complete the following statement.
You must show all your working.

[2]

36 miles is equal to km.

.....

.....

.....



11. (a) Simplify $4(x+6)+3x$. [2]

.....

.....

- (b) Solve $\frac{f}{3} = 5 \cdot 1$. [1]

.....

.....

- (c) $x = \frac{w(y+2)}{8}$
Find the value of x when $w = 3$ and $y = 24$. [2]

.....

.....

.....

.....

.....

12. (a) Calculate $\sqrt{5 \times 3 \cdot 8} + 2 \cdot 1^2$.
Give your answer correct to 2 decimal places. [2]

.....

.....

- (b) Write 0.05834 correct to 1 significant figure. [1]

.....



BLANK PAGE

**PLEASE DO NOT WRITE
ON THIS PAGE**



13. Ken measured the resting heart rate, in beats per minute (bpm), of twelve people. He asked them how many hours of exercise they usually completed each week. The results for seven of the people have been plotted on the scatter diagram.

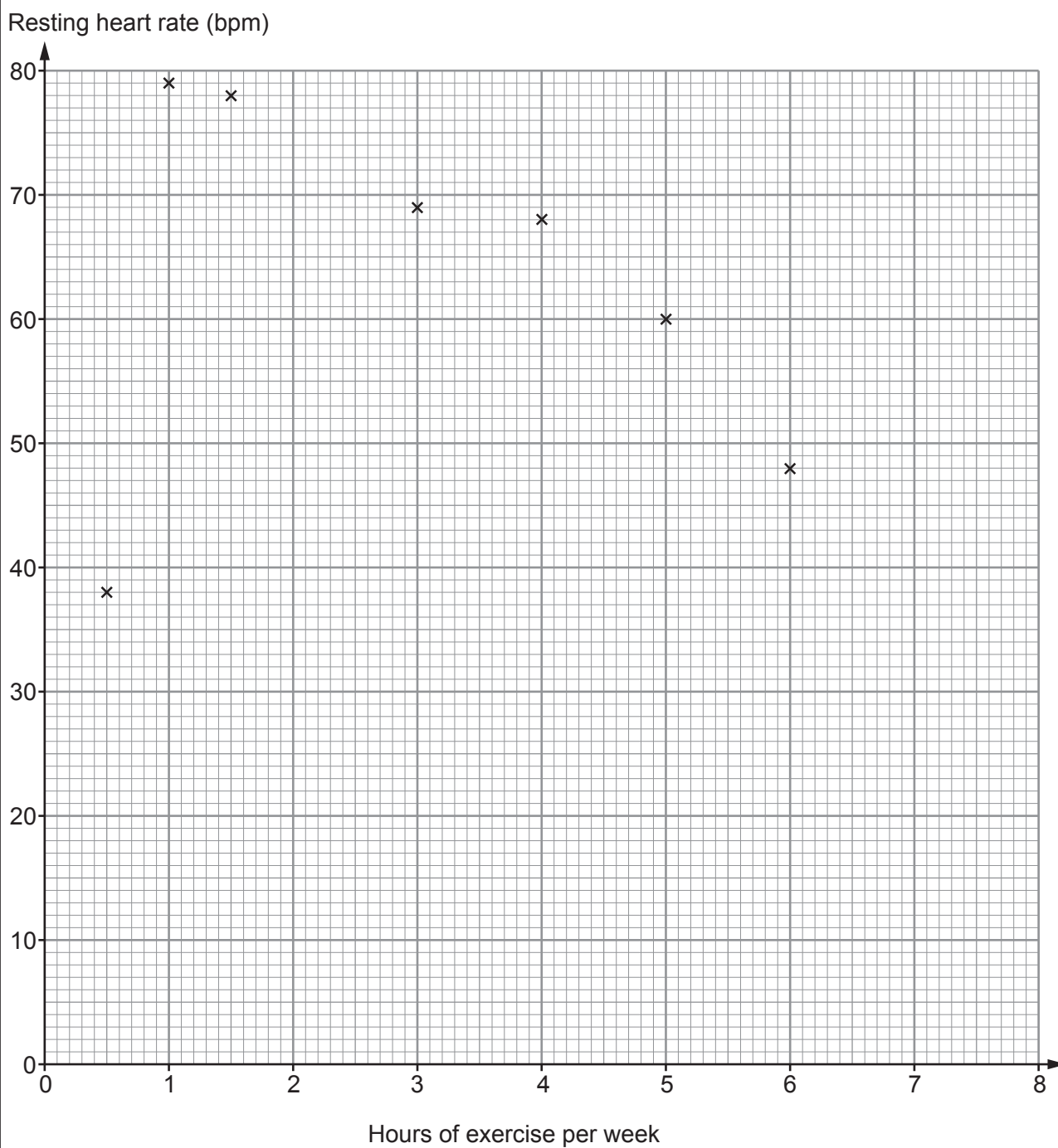

- (a) Here are the results for the remaining five people.

Hours of exercise per week	2	4	1	7	5.5
Resting heart rate (bpm)	70	58	60	55	57

Plot these results on the scatter diagram. [2]

- (b) Ken recorded one person's resting heart rate incorrectly.

Circle the point on the scatter diagram that this is most likely to be. [1]

- (c) Describe the relationship between hours of exercise per week and resting heart rate of the people Ken asked.

Ignore the result that was recorded incorrectly. [1]

.....

.....

.....



14. (a) Geomet High School has 740 students.

Each student was asked which method of travel listed below was their main method of travel to school.

The table below shows the methods of travel together with some of their probabilities.

Method of travel	Walk	Bus	Bike	Car	Train	Other
Probability	0.2	0.35	0.3			0

- (i) A student is chosen at random.

What is the probability that this student walks to school or travels to school by bus? [1]

.....

.....

- (ii) How many of the 740 students travel to school by bus? [2]

.....

.....

- (iii) The probability that a student travels to school by car is **twice** the probability that a student travels to school by train.

Calculate the probability that a student travels to school by train. [3]

.....

.....

.....

.....

.....



- (b) The Venn diagram shows information about the number of students who study Music and Drama in Year 11 at Geomet High School.

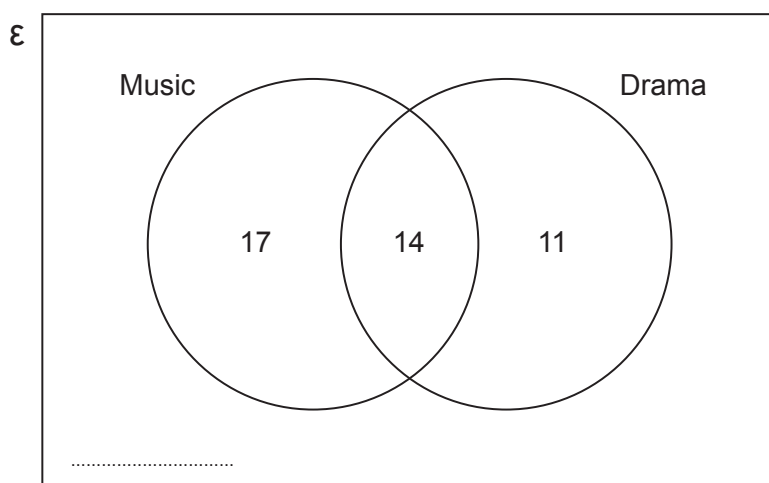

There are 104 students in Year 11.

- (i) Complete the Venn diagram to show the number of students in Year 11 who do **not** study Music or Drama. [1]

.....

- (ii) What is the probability that a student chosen at random from Year 11 studies Music? [2]

.....

.....

.....



15. A shop sells storage boxes.
A stack of four of these boxes is shown below.



Diagram not drawn to scale

The height of a single box is 35.2 cm.
The height of four of the same boxes when stacked is 52 cm.

A different stack of these boxes has a height of 85.6 cm.
How many boxes are in this stack?

[5]

.....

.....

.....

.....

.....

.....

.....

.....

.....

.....

.....



16. Make g the subject of the formula.

[2]

Examiner
only

$$h = k + 2g$$

.....

.....

.....

.....



17. (a) Translate this triangle using the vector $\begin{pmatrix} 3 \\ -4 \end{pmatrix}$. [2]

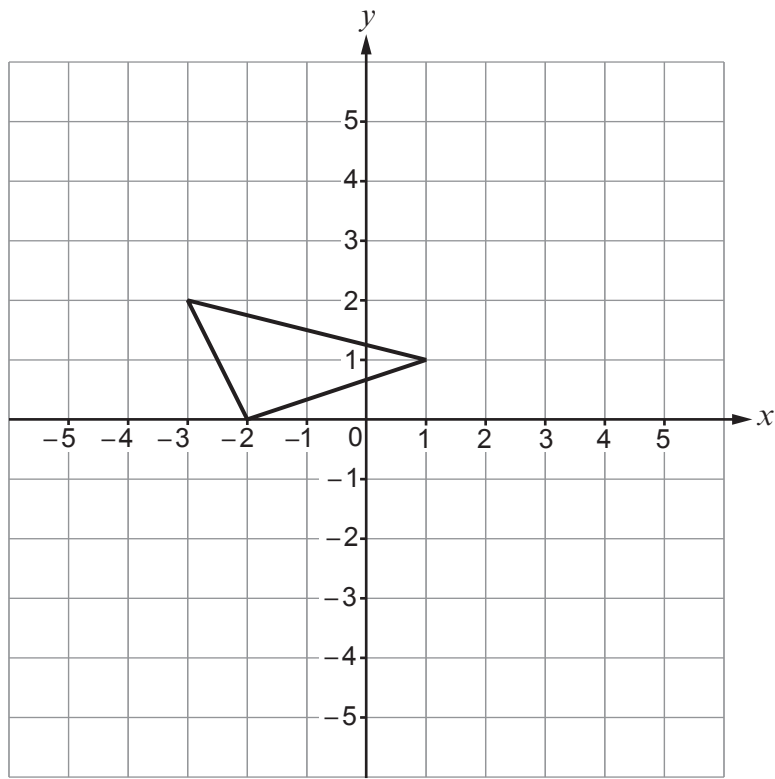

- (b) Rotate this shape 90° clockwise about the point (0,0). [2]

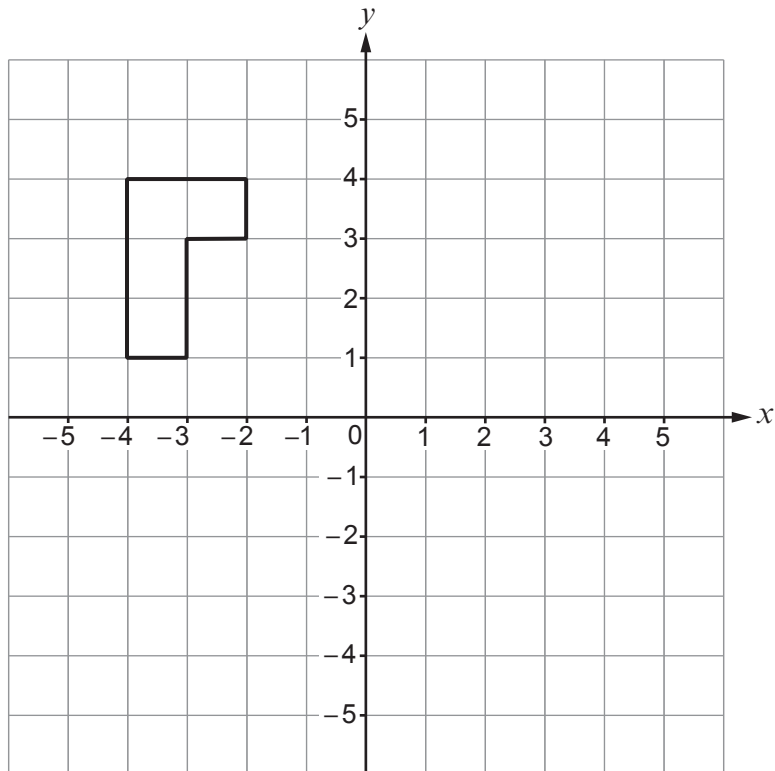

18.

Use:

$$\text{Pressure} = \frac{\text{Force (N)}}{\text{Area (cm}^2\text{)}}$$



The base of a filing cabinet is a rectangle. It measures 45 cm by 60 cm.
The whole of the base is in contact with the horizontal ground.

- (a) The empty filing cabinet exerts a force of 675 N on the ground.

What is the pressure exerted on the ground by the empty filing cabinet?
Give your answer in N/cm^2 .

[2]

.....

.....

.....

.....

.....

.....

- (b) When the filing cabinet is full, the pressure it exerts on the ground is 0.75 N/cm^2 .

What is the force that the full filing cabinet exerts on the ground?
Give your answer in newtons (N).

[2]

.....

.....

.....

.....

.....



19. The diagram shows information about the percentage of households in Eduvale that owned a **desktop** computer for the even-numbered years from 2006 to 2018.

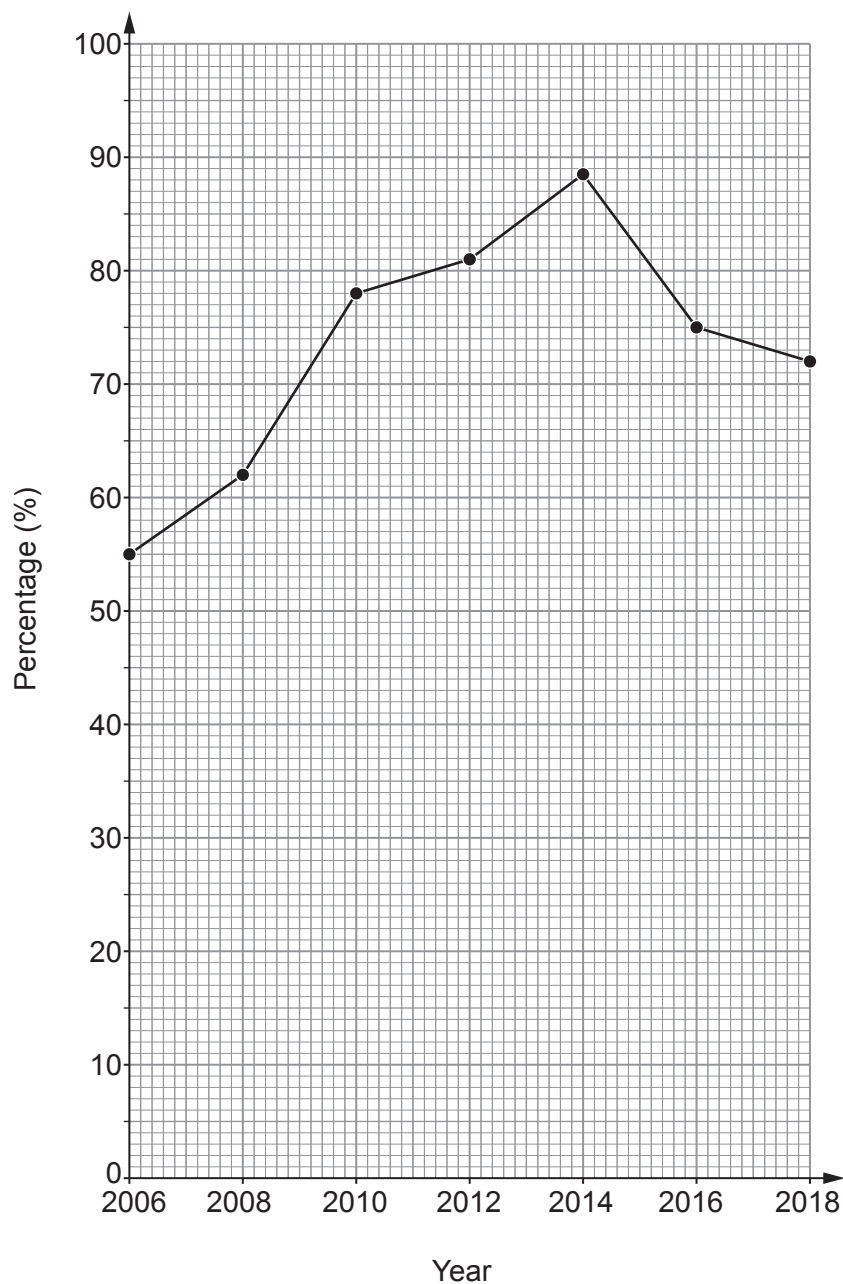

- (a) (i) Complete this statement. [1]

The percentage of households that owned a desktop computer decreased the most between the even-numbered years and



(ii) Jane says,

"The graph shows that 70% of people owned a desktop computer in 2009 because it passes through that point."

Is Jane correct?

Yes No

Explain how you decide.

[1]

.....

.....

.....

(b) The table shows information about the percentage of households in Eduvale that had an internet connection for the even-numbered years from 2006 to 2018.

Year	2006	2008	2010	2012	2014	2016	2018
Internet connection (%)	45	53	66	79	84	88	89

(i) On the diagram on page 24, plot the information for internet connection. [1]

(ii) In which even-numbered year was the difference in the percentage of households in Eduvale owning a desktop computer and the percentage of households having an internet connection the greatest? [1]

.....

(iii) Eduvale is a large town in a county.

Comment on how, in this **county**, the percentage of households owning a desktop computer and the percentage of households having an internet connection are **likely** to have changed in this time period. [1]

.....

.....

.....



20. (a) The diagram shows a circle inside a square of side 8.2 cm .

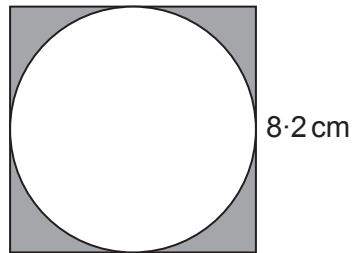

Diagram not drawn to scale

The sides of the square are tangents to the circle.

Find the area of the shaded region.
You must show all your working.

[4]

.....

.....

.....

.....

.....

.....

.....



- (b) The diagram shows a parallelogram.
It is the cross-section of a prism.

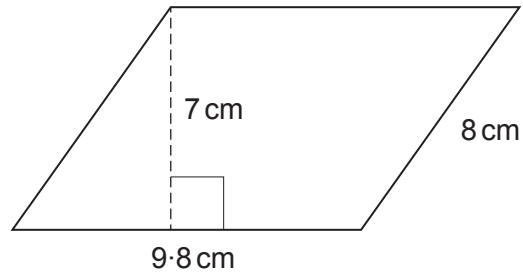

Diagram not drawn to scale

The length of the prism is 16 cm .
Find the volume of the prism.

[3]

.....

.....

.....

.....

.....



21. (a) Solve $7x - 5 = 2x + 3$.

[2]

.....

.....

.....

.....

.....

.....

(b) Roza is buying bananas and apples.

She buys x bananas which cost 30 pence each.

She buys 2 more apples than the number of bananas she buys.

Her apples cost 25 pence each.

She pays a total of £5.45.

Use an algebraic method to find the number of bananas Roza buys.

[4]

.....

.....

.....

.....

.....

.....

.....

.....

.....

.....

.....

(c) Factorise $x^2 + 5x + 4$.

[2]

.....

.....

.....

.....



22.

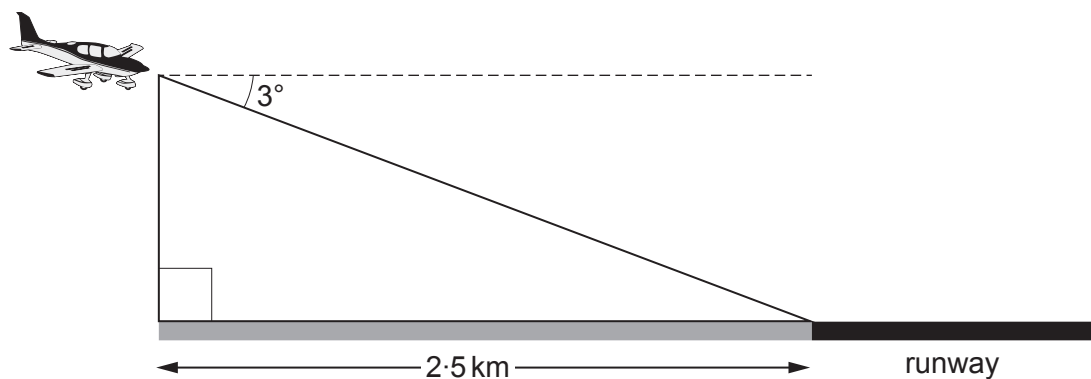

Diagram not drawn to scale

An aircraft is making its final approach ready to land.

The aircraft is:

- flying at 3° to the horizontal,
- 2.5 km horizontally from the start of the runway, as shown on the diagram above.

Calculate the vertical height of the aircraft above the horizontal ground.
You must show all your working.

[4]

.....

.....

.....

.....

.....

.....

.....

.....

.....

.....

.....

.....

.....

.....

.....

.....

.....

.....

.....

.....

.....

.....



23. Heath has £3000 to invest for five years.
No extra money will be paid in or withdrawn during these five years.
He is going to choose one of these accounts.

Account A
4% compound interest per year
Interest rates can vary

Account B
Guaranteed interest at the end of
5 years of £190 for
each £1000 invested

(a) Which account gives Heath the greater **percentage increase** in his money at the end of 5 years and by how much is it greater?

Show how you decide. State any assumption that you make.

[6]

.....
.....
.....
.....
.....
.....
.....
.....
.....
.....
.....
.....
.....
.....
.....
.....
.....
.....
.....
.....
.....
.....

Account gives the greater percentage increase by %

Assumption
.....
.....

(b) Comment on the effect that your assumption in part (a) has had on your decision. [1]

.....
.....



BLANK PAGE

**PLEASE DO NOT WRITE
ON THIS PAGE**

