

Please check the examination details below before entering your candidate information

Candidate surname

Other names

Centre Number

Candidate Number

| | | | | |
|--|--|--|--|--|
| | | | | |
|--|--|--|--|--|

| | | | |
|--|--|--|--|
| | | | |
|--|--|--|--|

Pearson Edexcel International GCSE

Time 2 hours

Paper
reference

4MA1/2F

Mathematics A

PAPER 2F

Foundation Tier



You must have: Ruler graduated in centimetres and millimetres, protractor, pair of compasses, pen, HB pencil, eraser, calculator. Tracing paper may be used.

Total Marks

Instructions

- Use **black** ink or ball-point pen.
- **Fill in the boxes** at the top of this page with your name, centre number and candidate number.
- Answer **all** questions.
- Without sufficient working, correct answers may be awarded no marks.
- Answer the questions in the spaces provided
– *there may be more space than you need.*
- **Calculators may be used.**
- You must **NOT** write anything on the formulae page.
- Anything you write on the formulae page will gain **NO** credit.

Information

- The total mark for this paper is 100.
- The marks for **each** question are shown in brackets
– *use this as a guide as to how much time to spend on each question.*

Advice

- Read each question carefully before you start to answer it.
- Check your answers if you have time at the end.

Turn over ►

P72439A

©2023 Pearson Education Ltd.

J:1/1/1/1/



Pearson

International GCSE Mathematics
Formulae sheet – Foundation Tier

Area of trapezium = $\frac{1}{2}(a + b)h$

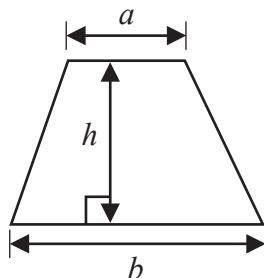

Volume of prism = area of cross section \times length

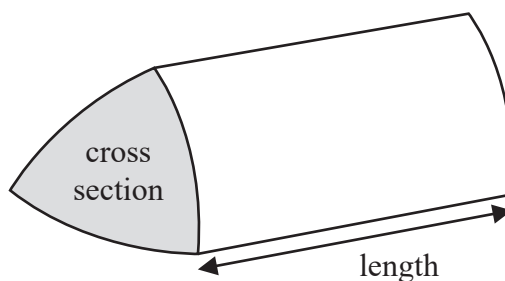

Volume of cylinder = $\pi r^2 h$

Curved surface area of cylinder = $2\pi r h$

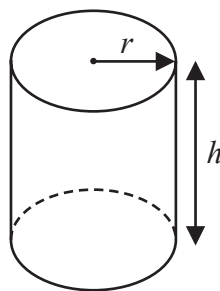

DO NOT WRITE IN THIS AREA

DO NOT WRITE IN THIS AREA

DO NOT WRITE IN THIS AREA



Answer ALL TWENTY FIVE questions.

Write your answers in the spaces provided.

You must write down all the stages in your working.

- 1 Here are four cards.
Each card has a number on it.

These four cards are arranged to make the number 5763

- (a) Arrange the four cards to make the smallest possible number.

(1)

- (b) Arrange the four cards to make the largest possible **even** number.

(1)

- (c) Arrange two of the cards to make a prime number.

(1)



- (d) Arrange two of the cards to make a multiple of 8

(1)

(Total for Question 1 is 4 marks)

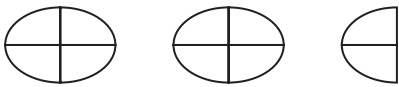
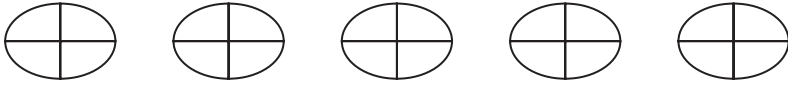
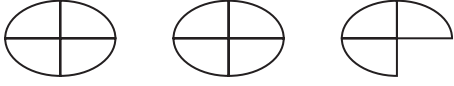

- 2 The pictogram shows information about the total weight of potatoes grown last year in each of five countries.

| | |
|------------------------|--|
| Bangladesh |  |
| USA |  |
| Germany |  |
| Poland |  |
| France |  |
| The Netherlands | |

Key:  represents 4 million tonnes of potatoes

The pictogram shows one country where the total weight of potatoes grown last year was 20 million tonnes.

- (a) Which country?

.....
(1)

Last year, the weight of potatoes grown in The Netherlands was 6 million tonnes.

- (b) Show this information on the pictogram.

(1)

- (c) Work out the total weight of potatoes grown in Germany **and** in France last year.

..... million tonnes
(2)

(Total for Question 2 is 4 marks)



3 Here is a number scale.

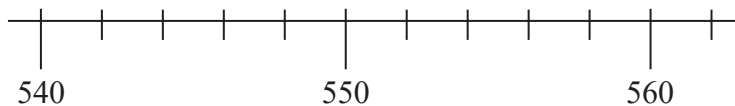

(a) On the scale, mark with an arrow (\uparrow) the number 554

(1)

Here is a different number scale.

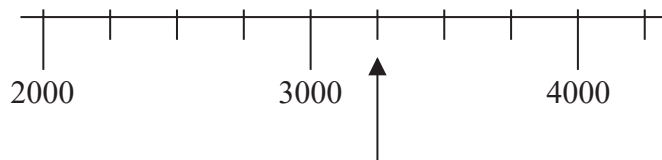

(b) Write down the number shown marked by the arrow.

.....
(1)

(Total for Question 3 is 2 marks)

4 (a) In the space below, draw a line of length 6.5 cm

(1)

The diagram shows the straight lines QP and QR

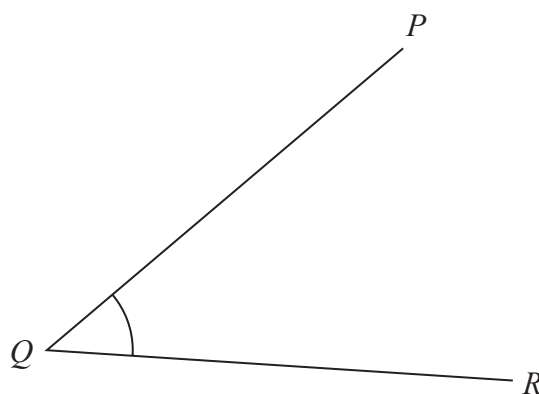

(b) Measure the size of angle PQR

.....
(1)

(Total for Question 4 is 2 marks)



5 The table gives information about the costs of sending parcels of different weights.

| Weight (w kg) | Cost of sending a parcel |
|------------------|--------------------------|
| $0 < w \leq 1$ | £6.00 |
| $1 < w \leq 2$ | £9.02 |
| $2 < w \leq 5$ | £15.85 |
| $5 < w \leq 10$ | £21.90 |

Peony has one parcel of weight 1.3 kg and another parcel of weight 8 kg to send to two different places.

(a) Work out the total cost of sending these two parcels.

£.....
(2)

Gryffyn sends 3 parcels each to a different place.

One of the parcels has a weight of 1.5 kg and another of the parcels has a weight of 2.8 kg

The total cost of sending the 3 parcels is £33.89

(b) Work out the greatest possible weight of the third parcel.

..... kg
(3)

(Total for Question 5 is 5 marks)



- 6 (a) Write 5 15 pm using the 24-hour clock.

.....
(1)

Roberta goes out for a walk.

She leaves home at 16 35

She arrives back home at 20 15 on the same day.

- (b) Work out for how much time Roberta is out for her walk.

..... hours minutes
(2)

(Total for Question 6 is 3 marks)

- 7 (a) Simplify $c \times c \times c \times c \times c$

.....
(1)

- (b) Solve $5 + x = 12$

$x =$
(1)

- (c) Solve $\frac{y}{6} = 3$

$y =$
(1)

- (d) Expand $5(2 + 3h)$

.....
(1)

- (e) Factorise $g^2 + 7g$

.....
(1)

(Total for Question 7 is 5 marks)



8 Here is a number machine.

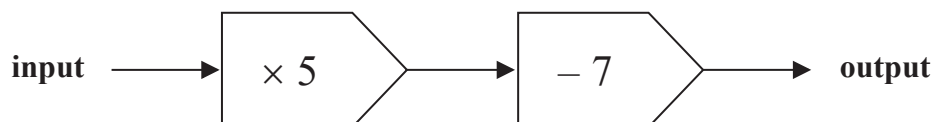

(a) Work out the output when the input is 9

.....
(1)

Here is a different number machine.

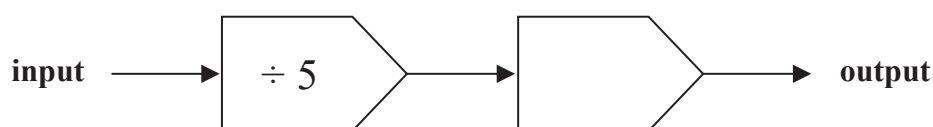

When the input is 30 the output is 18

(b) Find a suitable way to complete the number machine.

(1)

The following rule is used to work out the total cost, in euros, of hiring a cement mixer.

$$\text{Total cost} = 8 \text{ euros per day plus } 5 \text{ euros}$$

James hires a cement mixer for 3 days.

(c) Work out the cost to James of hiring the cement mixer.

..... euros

(1)

The cost to Sophia of hiring a cement mixer is 61 euros.

(d) For how many days does Sophia hire the cement mixer?

..... days

(2)

(Total for Question 8 is 5 marks)



- 9 There are 120 cyclists in a cycling club.
There are 67 professional cyclists and the rest are amateur cyclists.
Each of these cyclists was asked to name their favourite type of bike.

The two-way table shows some information about their answers.

| | Road bike | Mountain bike | Hybrid bike | Total |
|--------------|-----------|---------------|-------------|-------|
| Professional | 26 | | | 67 |
| Amateur | | 32 | | |
| Total | 39 | 54 | | 120 |

- (a) Complete the table.

(3)

- (b) Work out the percentage of the cyclists who answered Mountain bike.

.....%

(2)

Jacob is going to draw a pie chart for the age groups of the 120 cyclists.
There are 41 people in the 'over 60' age group.

- (c) Work out the size of the angle for the sector representing the 'over 60' age group.

.....°

(2)

(Total for Question 9 is 7 marks)



- 10 The frequency table shows information about the number of cookies made by each of the 21 people in a cookery class.

| Number of cookies made | Frequency |
|------------------------|-----------|
| 10 | 1 |
| 11 | 7 |
| 12 | 2 |
| 13 | 5 |
| 14 | 4 |
| 15 | 2 |

- (a) Write down the mode of the number of cookies made.

.....
(1)

- (b) Find the median number of cookies made.

.....
(2)

- (c) Find the total number of cookies made by the 21 people in the cookery class.

.....
(2)

(Total for Question 10 is 5 marks)



11 (a) Work out the value of $(4 + 3 + 6)^2$

.....
(1)

$$64 = 4^n$$

(b) Write down the value of n

$n =$
(1)

(c) Work out the value of $\frac{\sqrt{9.3 + 2.8^3}}{3.2 \times 1.2}$

Write down all the figures on your calculator display.

.....
(2)

(Total for Question 11 is 4 marks)

12 Last season, Alisha and Jaya scored goals for their team in the ratio 4 : 7
Jaya scored 39 more goals than Alisha.

Work out the number of goals Alisha scored.

.....
(Total for Question 12 is 3 marks)



- 13** There are 380 students in a Sixth Form.
The students are either in the Upper Sixth or in the Lower Sixth.

The number of students in the Upper Sixth is 20 fewer than the number of students in the Lower Sixth.

$\frac{2}{5}$ of the Upper Sixth students study mathematics.

32% of the Lower Sixth students study mathematics.

Work out the total number of students in the Sixth Form who study mathematics.

DO NOT WRITE IN THIS AREA

DO NOT WRITE IN THIS AREA

DO NOT WRITE IN THIS AREA

.....
(Total for Question 13 is 4 marks)



DO NOT WRITE IN THIS AREA

DO NOT WRITE IN THIS AREA

DO NOT WRITE IN THIS AREA

14 The diagram shows a solid prism.

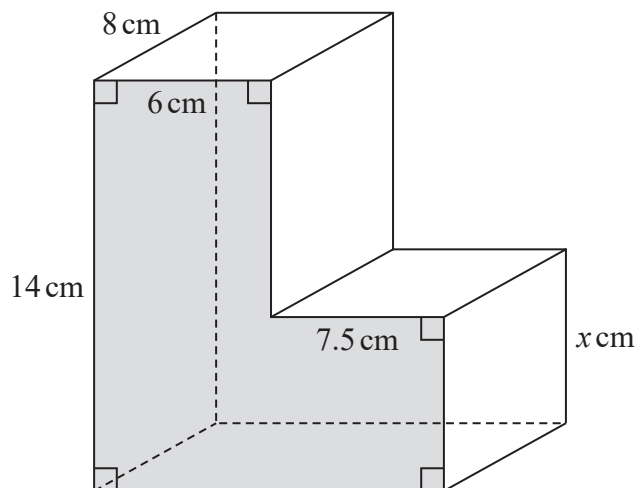

Diagram **NOT** accurately drawn

The cross section of the prism is shown shaded.

The volume of the prism is 924 cm^3

Work out the value of x

$x = \dots\dots\dots$

(Total for Question 14 is 4 marks)



15 The diagram shows two parallel lines AB and DEF

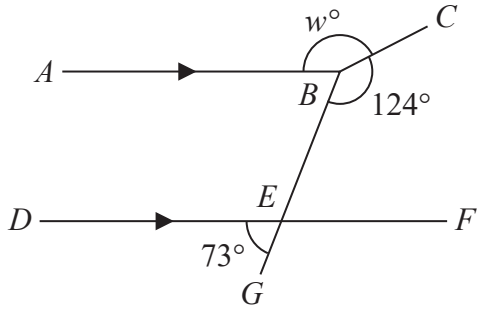

Diagram NOT accurately drawn

BEG is a straight line.

angle $DEG = 73^\circ$ angle $EBC = 124^\circ$ angle $ABC = w^\circ$

Work out the value of w
Give reasons for each stage of your working.

$w = \dots\dots\dots$

(Total for Question 15 is 4 marks)

DO NOT WRITE IN THIS AREA

DO NOT WRITE IN THIS AREA

DO NOT WRITE IN THIS AREA



DO NOT WRITE IN THIS AREA

DO NOT WRITE IN THIS AREA

DO NOT WRITE IN THIS AREA

16 Show that $3\frac{5}{7} \div 1\frac{5}{8} = 2\frac{2}{7}$

(Total for Question 16 is 3 marks)

17 Change a speed of 90 kilometres per hour to a speed in metres per second.
Show your working clearly.

..... m/s

(Total for Question 17 is 3 marks)



18 $\mathcal{E} = \{11, 12, 13, 14, 15, 16, 17, 18, 19, 20\}$

$A = \{\text{even numbers}\}$

$A \cap B = \{12, 16, 20\}$

$(A \cup B)' = \{17, 19\}$

Complete the Venn diagram for the sets \mathcal{E} , A and B

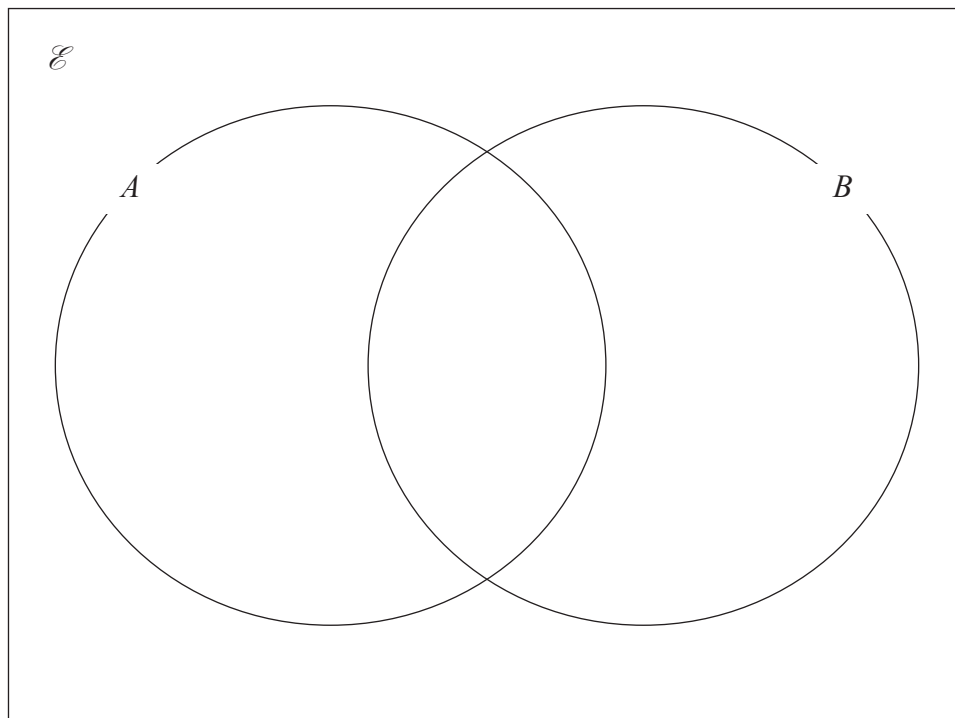

(Total for Question 18 is 3 marks)

DO NOT WRITE IN THIS AREA

DO NOT WRITE IN THIS AREA

DO NOT WRITE IN THIS AREA



DO NOT WRITE IN THIS AREA

DO NOT WRITE IN THIS AREA

DO NOT WRITE IN THIS AREA

19 The diagram shows rectangle $ABCD$

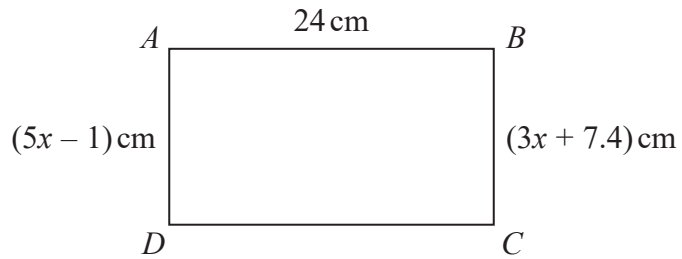

Diagram **NOT** accurately drawn

Work out the perimeter of the rectangle.
Show your working clearly.

..... cm

(Total for Question 19 is 4 marks)



P 7 2 4 3 9 A 0 1 7 2 4

20 The weight of a cake is 2.75 kg, correct to 2 decimal places.

(a) Write down the lower bound of the weight of the cake.

..... kg

(1)

(b) Write down the upper bound of the weight of the cake.

..... kg

(1)

Penny has worked out $\frac{81.3 \times 59.2}{1.9^2}$ on her calculator.

Her answer is 13 332.299 17

Penny's answer is not sensible.

(c) By rounding each number to one significant figure, work out a suitable estimate to show that her answer is not sensible.
Show your working clearly.

(2)

(Total for Question 20 is 4 marks)



21 The points A and B are on a coordinate grid.

The coordinates of A are $(6, 4)$

The coordinates of B are $(17, j)$ where j is a constant.

The midpoint of AB has coordinates $(k, 15)$ where k is a constant.

Find the value of j and the value of k

$$j = \dots\dots\dots$$

$$k = \dots\dots\dots$$

(Total for Question 21 is 3 marks)

22 Solve the simultaneous equations

$$5x + 4y = -2$$

$$2x - y = 4.4$$

Show clear algebraic working.

$$x = \dots\dots\dots$$

$$y = \dots\dots\dots$$

(Total for Question 22 is 3 marks)



23 Matteo is going to invest 5000 Swiss francs for two years.

He can invest his money in Bank G or in Bank H.

Bank G
1.6% per year
compound interest

Bank H
2.9% interest added after
two years

The total amount of interest Matteo would receive at the end of two years from Bank G is more than the amount of interest Matteo would receive at the end of two years from Bank H.

How much more?

..... Swiss francs

(Total for Question 23 is 4 marks)

DO NOT WRITE IN THIS AREA

DO NOT WRITE IN THIS AREA

DO NOT WRITE IN THIS AREA



24 (a) Write down the value of $(m + 2)^0$ where m is a positive integer.

.....
(1)

(b) Simplify $(3a^2b^4)^3$

.....
(2)

(c) Factorise fully $14x^2y^4 + 21x^3y^2$

.....
(2)

The diagram shows a straight line drawn on a grid.

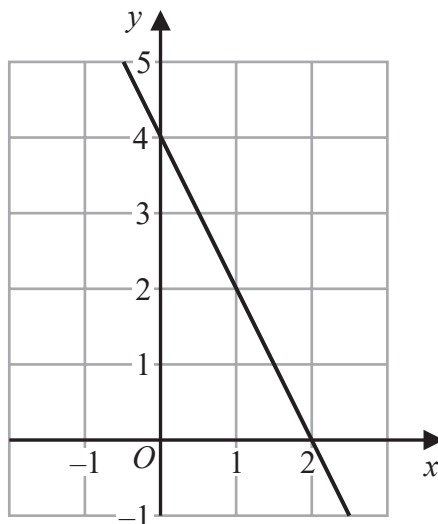

(d) Write down an equation of the line.

.....
(2)

(Total for Question 24 is 7 marks)



25 The diagram shows an isosceles triangle, with base length 24 cm.

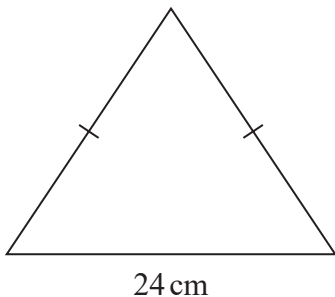

Diagram **NOT** accurately drawn

The perimeter of the triangle is 54 cm.

Work out the area of the triangle.

..... cm²

(Total for Question 25 is 5 marks)

TOTAL FOR PAPER IS 100 MARKS

DO NOT WRITE IN THIS AREA

DO NOT WRITE IN THIS AREA

DO NOT WRITE IN THIS AREA



DO NOT WRITE IN THIS AREA

DO NOT WRITE IN THIS AREA

DO NOT WRITE IN THIS AREA

BLANK PAGE



DO NOT WRITE IN THIS AREA

DO NOT WRITE IN THIS AREA

DO NOT WRITE IN THIS AREA

BLANK PAGE

