



Please write clearly in block capitals.

Centre number

Candidate number

Surname \_\_\_\_\_

Forename(s) \_\_\_\_\_

Candidate signature \_\_\_\_\_

I declare this is my own work.

# GCSE COMBINED SCIENCE: TRILOGY

# F

Foundation Tier  
Chemistry Paper 2F

Time allowed: 1 hour 15 minutes

### Materials

For this paper you must have:

- a ruler
- a scientific calculator
- the periodic table (enclosed).

### Instructions

- Use black ink or black ball-point pen.
- Pencil should only be used for drawing.
- Fill in the boxes at the top of this page.
- Answer **all** questions in the spaces provided.
- If you need extra space for your answer(s), use the lined pages at the end of this book. Write the question number against your answer(s).
- Do all rough work in this book. Cross through any work you do not want to be marked.
- In all calculations, show clearly how you work out your answer.

### Information

- The maximum mark for this paper is 70.
- The marks for questions are shown in brackets.
- You are expected to use a calculator where appropriate.
- You are reminded of the need for good English and clear presentation in your answers.

For Examiner's Use	
Question	Mark
1	
2	
3	
4	
5	
6	
7	
<b>TOTAL</b>	



J U N 2 2 8 4 6 4 C 2 F 0 1

1B/M/Jun22/E11

8464/C/2F

# MME. Revision Products - GCSE Science

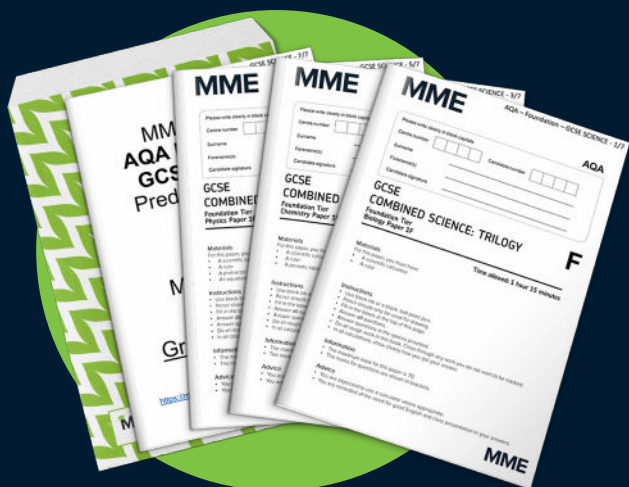

GCSE Combined Science  
Predicted Papers 2024

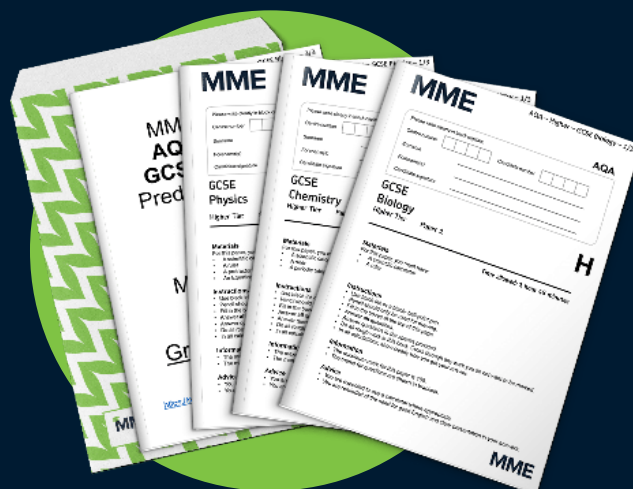

AQA GCSE Triple Science  
Predicted Papers 2024

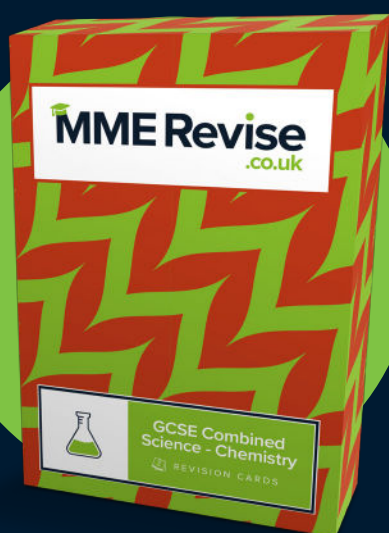

GCSE Combined  
Science Revision Cards

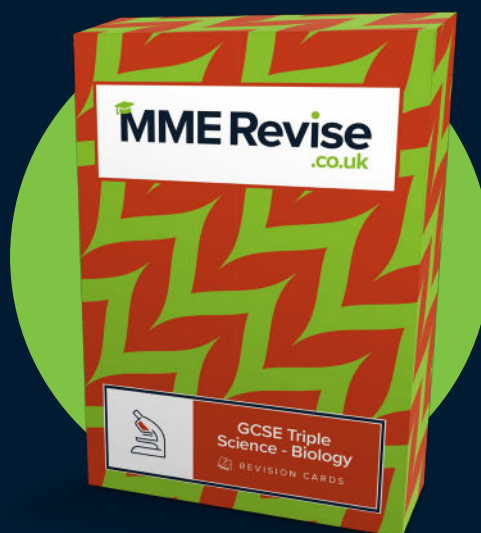

GCSE Triple Science  
Revision Cards

 [View All GCSE Science](#)

[mmerevise.co.uk](https://mmerevise.co.uk)

0 1

This question is about the Earth's atmosphere.

0 1 . 1

The Earth's atmosphere contains 21% oxygen.

Draw the bar for oxygen on Figure 1.

[1 mark]

Figure 1

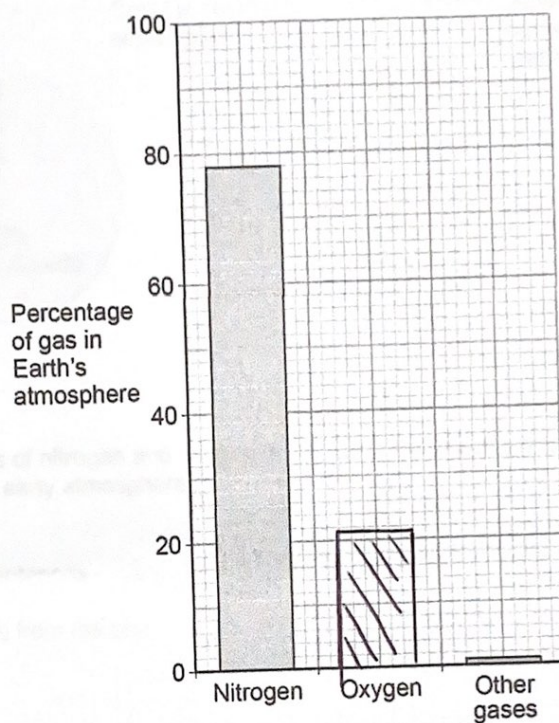

0 1 . 2

What is used to test for oxygen gas?

[1 mark]

Tick (✓) **one** box.A burning splint A glowing splint Damp litmus paper Limewater 

The Earth's early atmosphere was very different from the Earth's atmosphere today.

**Figure 2** shows the composition of the Earth's early atmosphere and of the Earth's atmosphere today.

**Figure 2**

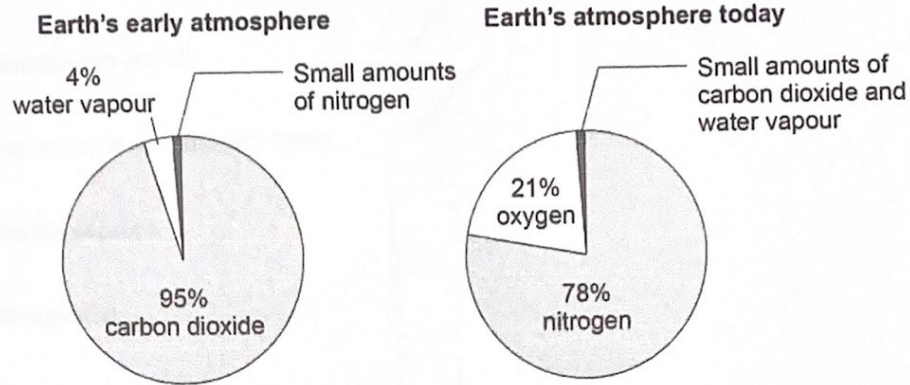

**0 1 . 3** The percentages of nitrogen and oxygen in the Earth's atmosphere today are different from the Earth's early atmosphere.

Complete the sentences.

Choose answers from the box.

Use **Figure 2**.

Each answer can be used once, more than once or not at all.

[2 marks]

decreased      increased      stayed the same

Since the Earth's early atmosphere, the percentage of nitrogen in the Earth's atmosphere has increased.

Since the Earth's early atmosphere, the percentage of oxygen in the Earth's atmosphere has increased.

Turn over ►



Do not write  
outside the  
box

**0 1 . 4** The Earth's atmosphere today contains a small amount of carbon dioxide.

Why has the percentage of carbon dioxide decreased since the Earth's early atmosphere?

**[2 marks]**

Tick (✓) **two** boxes.

- Dissolved in oceans
- Formation of sedimentary rocks
- Industrialisation
- Respiration
- Volcanic activity



Oxides of nitrogen are produced when nitrogen reacts with oxygen in car engines.

Figure 3 shows the concentration of oxides of nitrogen in the atmosphere during one day in a city.

Figure 3

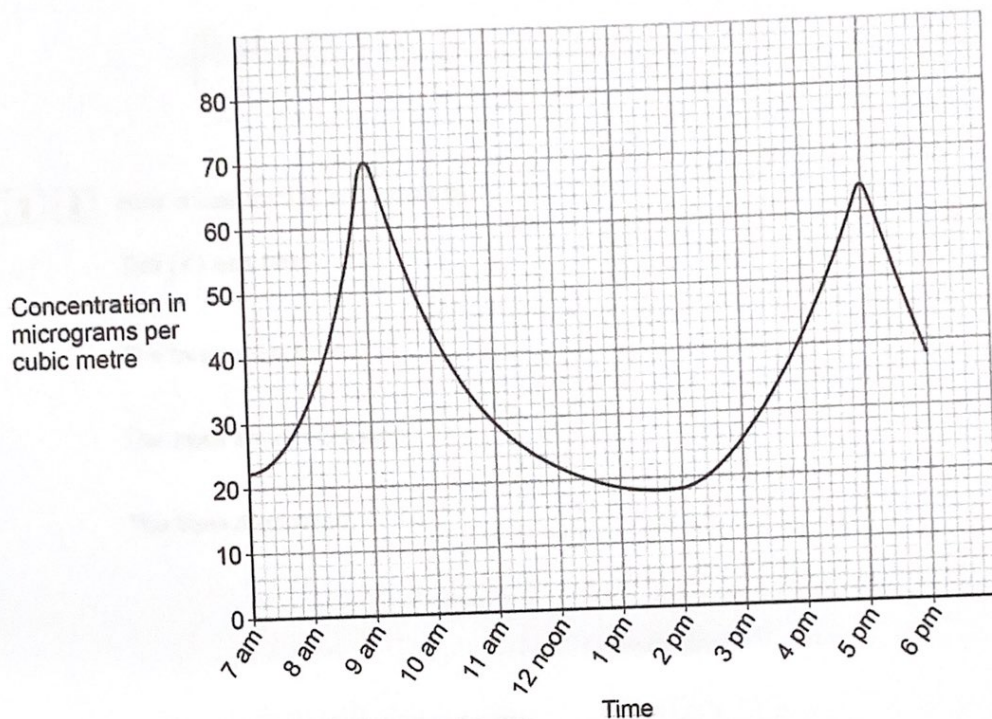

0 1 . 5 Which **two times** have the highest concentrations of oxides of nitrogen in the atmosphere? [2 marks]

- 1 9 am
- 2 5 pm

0 1 . 6 Suggest why there are the highest concentrations of oxides of nitrogen at these times. [1 mark]

There are more cars on the roads  
as it is commuting hours.

9

Turn over ►



0 2

This question is about fuels.

Coal deposits were formed from the remains of trees.

0 2 . 1

Name the process in the leaves of trees that uses carbon dioxide.

[1 mark]

photosynthesis

0 2 . 2

How is coal formed after trees die?

[1 mark]

Tick (✓) **one** box.

The trees are burned.

The trees are compressed.

The trees are melted.

Coal contains small amounts of sulfur.

0 2 . 3

Name the gas produced when sulfur burns in oxygen.

[1 mark]

Sulfur dioxide

0 2 . 4

Give **two** problems caused by the gas produced when sulfur burns in oxygen.

[2 marks]

1 Acid rain2 Respiratory problems

0 2 . 5

Figure 4 shows the relative amount of electricity generated from different fuel sources in the UK from 2012 to 2018.

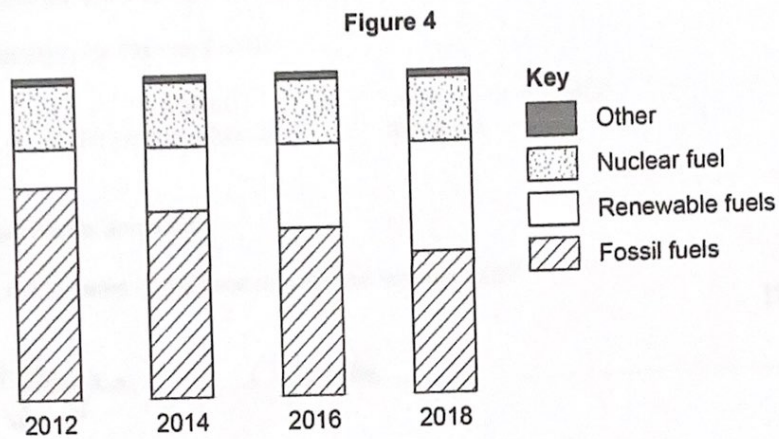

Describe what happens to the amounts of fuels used to generate electricity in the UK from 2012 to 2018.

[3 marks]

The amount of nuclear fuel remains constant from 2012 to 2018. The amount of renewable fuels increases, and the amount of fossil fuels decreased from 2012 to 2018.

8

Turn over for the next question

Turn over ►





0 3

This question is about ammonia and its compounds.

A student heated a sample of ammonium chloride.

The equation for the reaction is:

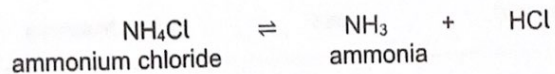

0 3 . 1

One product is ammonia.

What is the name of the product with the formula HCl?

[1 mark]

Hydrogen chloride

0 3 . 2

Ammonia is a gas.

What is the state symbol for ammonia?

[1 mark]

Tick (✓) **one** box.

(aq)

(g)

(l)

(s)

0 3 . 3

How does the equation show that the reaction is reversible?

[1 mark]

~~Exothermic~~  $\rightleftharpoons$  reversible arrow

0 3 . 4

Complete the sentence.

[1 mark]

The forward reaction is endothermic,

so the reverse reaction is ~~end~~ exothermic.



0 3 . 5

Complete the sentence.

Choose the answer from the box.

[1 mark]

concentration

rate

temperature

Equilibrium is reached when the forward and reverse reactions happen at exactly the same rate.

Question 3 continues on the next page

Turn over ►



0 9

The industrial process to produce ammonia uses a catalyst.

0 3 . 6 Figure 5 shows the reaction profile for the reaction with and without a catalyst.

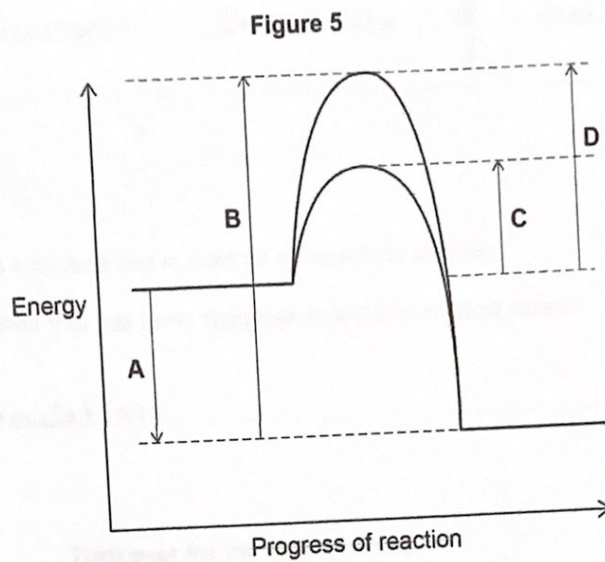

Which letter represents the activation energy for the reaction with a catalyst? [1 mark]

Tick (✓) one box.

A

B

C

D



Do not write  
outside the  
box

0 3 . 7

Give one reason why using a catalyst reduces costs.

Do not answer in terms of activation energy.

[1 mark]

It increases the rate of reaction.

0 3 . 8

Ammonia is in a mixture that is used as a household cleaner.

What is a mixture that has been designed as a useful product called?

[1 mark]

Formulation.

8

Turn over for the next question

Turn over ►



0 4

A student investigates the effect of concentration on the rate of the reaction between sodium thiosulfate solution and hydrochloric acid.

Figure 6 shows the experiment.

The experiment was done in a fume cupboard.

Figure 6

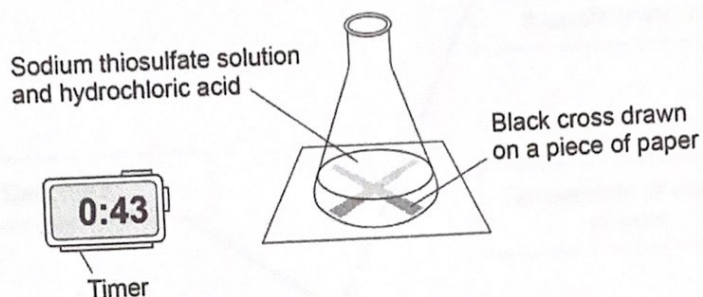

This is the method used.

1. Pour 50 cm<sup>3</sup> of sodium thiosulfate solution into a conical flask.
2. Put the conical flask on a black cross drawn on a piece of paper.
3. Pour 10 cm<sup>3</sup> of hydrochloric acid into the conical flask and start a timer.
4. Stop the timer when the cross can no longer be seen.
5. Repeat the experiment with different concentrations of sodium thiosulfate solution.



Do not write outside the box

0 4 . 1

Draw **one** line from each type of variable to the correct example of the variable in this investigation.

[2 marks]

Type of variable

Example of variable

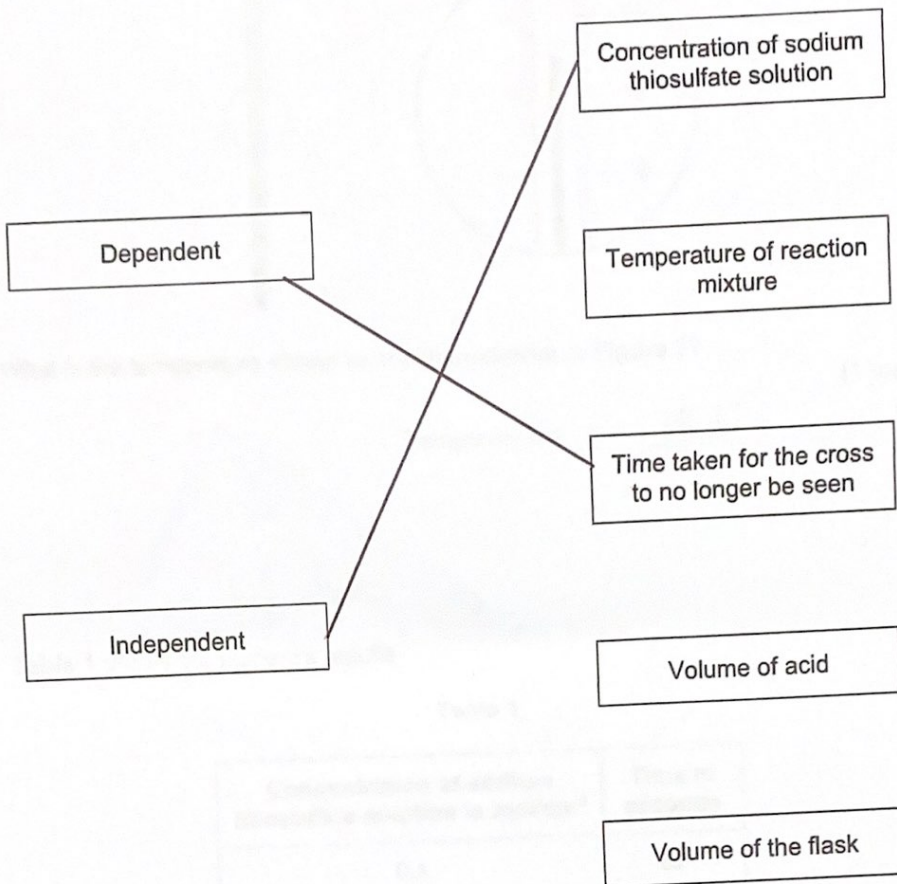

Question 4 continues on the next page

Turn over ►



0 4 . 2 The experiment is done at room temperature.

Figure 7

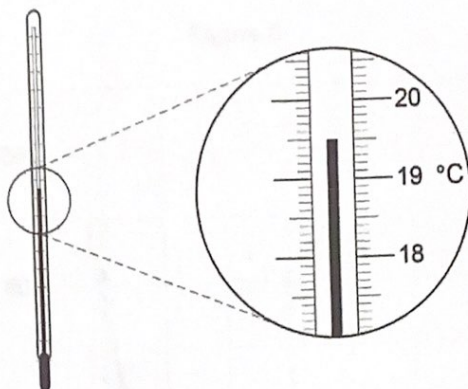

What is the temperature shown on the thermometer in Figure 7?

[1 mark]

Temperature = 19.5 °C

Table 1 shows the student's results.

Table 1

Concentration of sodium thiosulfate solution in mol/dm <sup>3</sup>	Time in seconds
0.1	82
0.2	40
0.3	20
0.4	13
0.5	10
0.6	8



0 4 . 3 Plot the data from Table 1 on Figure 8.

Draw a line of best fit.

[3 marks]

Figure 8

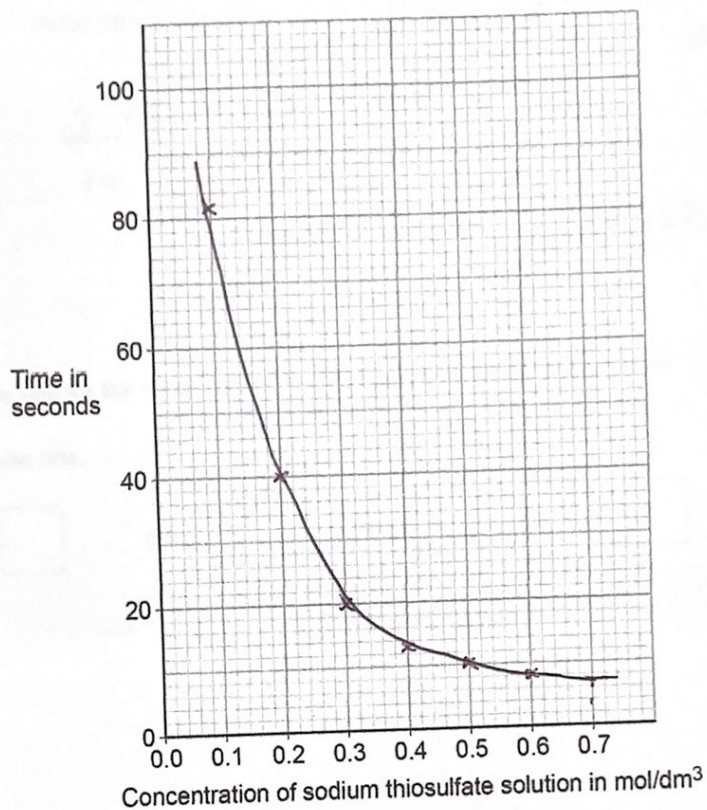

0 4 . 4

Predict the time taken for the cross to no longer be seen at a concentration of 0.7 mol/dm<sup>3</sup>

Use your graph in Figure 8.

[1 mark]

Time = 11 7 s

0 4 . 5

Complete the sentence.

[1 mark]

As the concentration of sodium thiosulfate solution increases, the time taken for the cross to no longer be seen decreases.

Turn over ►





04.6

In one experiment 0.725 g of sulfur is produced in 20 seconds.

Calculate the mean rate of the reaction from 0 to 20 seconds.

Use the equation:

$$\text{mean rate of reaction} = \frac{\text{mass of sulfur produced in grams}}{\text{time in seconds}}$$

[2 marks]

$$\text{Mean} = \frac{0.725}{20} = 0.03625$$

$$\text{Mean rate of reaction} = 0.03625$$

04.7

What is the unit for the mean rate of reaction calculated in Question 04.6?

[1 mark]

Tick (✓) one box.

g

g/s

s

s/g



0 4 . 8

The student did the experiment with  $0.15 \text{ mol/dm}^3$  sodium thiosulfate solution and repeated the experiment three more times.

Table 2 shows the results.

Table 2

	Test 1	Test 2	Test 3	Test 4
Time in seconds for the cross to no longer be seen	60.5	63.2	82.3	65.7

Calculate the mean time for this reaction.

Do **not** include the anomalous result in your calculation.

Give your answer to 3 significant figures.

[3 marks]

$$\begin{aligned} \text{Mean} &= \frac{60.5 + 63.2 + 65.7}{3} \\ &= 63.1333 \dots \\ &= 63.1 \text{ to } 3 \text{ significant figures} \end{aligned}$$

Mean time for the reaction (3 significant figures) = 63.1 s

14

Turn over for the next question

Turn over ►



0 5

This question is about hydrocarbons.

Figure 9 shows a hydrocarbon.

Figure 9

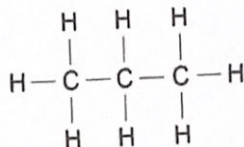

0 5 . 1

Complete the formula for the hydrocarbon shown in Figure 9.

[1 mark]

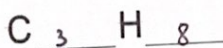

0 5 . 2

What is the name of the hydrocarbon in Figure 9?

[1 mark]

propane

0 5 . 3

Which homologous series does the hydrocarbon in Figure 9 belong to?

[1 mark]

Alkanes



0 5 . 4

30 g of another hydrocarbon contains 24 g of carbon.

Which calculation gives the percentage of carbon in the hydrocarbon?

[1 mark]

Tick (✓) **one** box.

$$\frac{24 \times 30}{100}$$

$$\frac{100 \times 30}{24}$$

$$\frac{24 \times 100}{30}$$

$$\frac{24}{30 \times 100}$$

0 5 . 5

Table 3 shows boiling points of some hydrocarbons.

Table 3

Formula of hydrocarbon	Boiling point in °C
C <sub>2</sub> H <sub>6</sub>	-89
C <sub>4</sub> H <sub>10</sub>	0
C <sub>6</sub> H <sub>14</sub>	69
C <sub>8</sub> H <sub>18</sub>	125
C <sub>10</sub> H <sub>22</sub>	174

Describe how the boiling points change as the number of carbon atoms in the hydrocarbon increases.

[1 mark]

As the number of carbon atoms increases, the boiling point increases.

Turn over ►



Hydrocarbons can be cracked.

0 5 . 6 Give **one** condition used to crack hydrocarbons. [1 mark]

A high pressure is needed to crack hydrocarbons.

0 5 . 7 Balance the equation for the cracking of  $C_6H_{14}$  [1 mark]

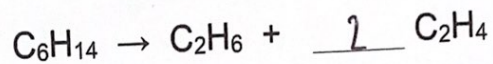

0 5 . 8 Give **one** reason why hydrocarbons are cracked. [1 mark]

They are cracked in order to produce fuels.



Do not write  
outside the  
box

0 5 . 9

Window frames can be manufactured from wood or plastic.

Table 4 shows the results of a life cycle assessment (LCA) for making one wooden and one plastic window frame.

Both window frames are the same size.

Table 4

Table 4 not reproduced here due to third-party copyright restrictions

Give **three** advantages of using wood instead of plastic in the manufacture of window frames.

[3 marks]

Advantage of wood 1 It uses less energy.

Advantage of wood 2 It uses less coal

Advantage of wood 3 Wood is renewable and sustainable

11

Turn over for the next question

Turn over ►



0 6

A student investigated the colours in a brown ink using chromatography.

0 6 . 1

Figure 10 shows the apparatus used.

Figure 10

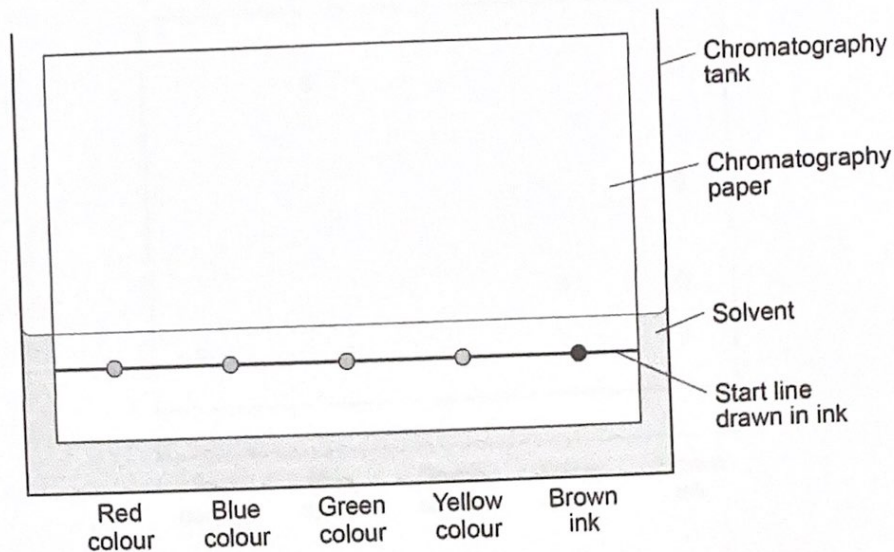

Give **two** errors made by the student.

Describe the problem each error would cause.

[4 marks]

Error 1 The start line drawn in ink.

Problem 1 It will mix with the solvent

Error 2 There is no lid on the tank.

Problem 2 The solvent will evaporate.



A different student set up the apparatus correctly.

Figure 11 shows the results.

Figure 11

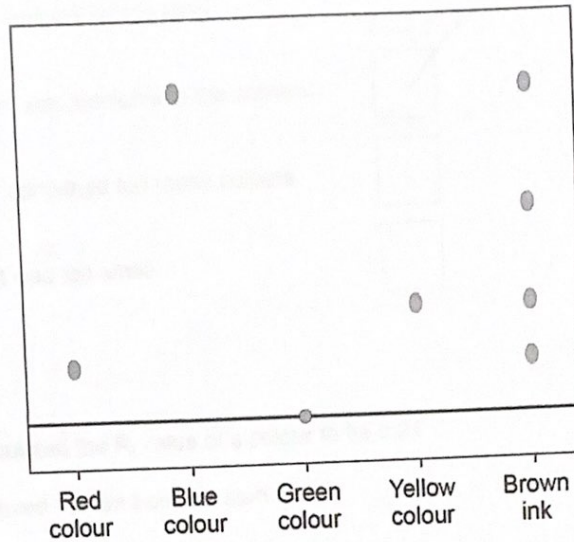

0 6 . 2

Give **two** conclusions the student can make from **Figure 11** about the four colours in the brown ink.

[2 marks]

- 1 The brown ink contains an unknown colour.
- 2 The brown ink does not contain green ink.

Question 6 continues on the next page

Turn over ►





0 6 . 3 Why was the green colour still on the start line at the end of the experiment? [1 mark]

Tick (✓) **one** box.

The experiment was left for too long.

The green colour was insoluble in the solvent.

The green spot contained too many colours.

The green spot was too small.

0 6 . 4 A student calculated the  $R_f$  value of a colour to be 0.24

The colour moved 1.8 cm from the start line.

Calculate the distance the solvent moved.

Use the equation:

$$R_f = \frac{\text{distance moved by colour}}{\text{distance moved by solvent}}$$

[3 marks]

$$0.24 = \frac{1.8}{\text{distance moved by solvent}}$$

$$\text{Distance moved by solvent} = 1.8 / 0.24 = 7.5 \text{ cm}$$

$$\text{Distance moved by solvent} = 7.5 \text{ cm}$$

10



07.1

Water that is safe to drink is called potable water.

Compare how easily potable water can be obtained from:

- waste water (sewage)
- ground water (fresh water).

[6 marks]

Generally, ground water can be easier to obtain, as it takes fewer processes and less time.

Waste water requires screening and grit removal to remove large particles.

It then requires sedimentation to produce sewage, sludge and effluent. The effluent

is then subject to aerobic biological treatment to reduce solid waste. This

is then sterilised using chlorine, ozone or UV light to kill bacteria. Ground

water is also sterilised after it is filtered to remove insoluble molecules. The

waste water sludge is also anaerobically digested by specific bacteria to remove organic matter.

Question 7 continues on the next page

Turn over ►



A scientist produced potable water from  $150 \text{ cm}^3$  of salty water.

07.2

Which process can be used to produce potable water from salty water?

[1 mark]

Tick (✓) **one** box.

Distillation

Electrolysis

Filtration

Sterilisation

07.3

The salty water contains sodium chloride.

The scientist collected 2.40 g of sodium chloride from  $150 \text{ cm}^3$  of salty water.

Calculate the concentration of sodium chloride in grams per  $\text{dm}^3$

[3 marks]

$$\frac{150 \text{ cm}^3 \text{ in } \text{dm}^3 \cdot \frac{150}{1000}}{1000} = 0.15 \text{ dm}^3$$

$$\text{Concentration} = \frac{2.40}{0.15} = 16 \text{ g/dm}^3$$

Concentration of sodium chloride = 16 g/dm<sup>3</sup>

10

END OF QUESTIONS

